



CMS80F731x Series

Reference Manual

Enhanced flash 8-bit 1T 8051 microcontroller
Rev. 1.0.3

Please be reminded about following CMS's policies on intellectual property

* Cmsemicon Limited(denoted as 'our company' for later use) has already applied for relative patents and entitled legal rights. Any patents related to CMS's MCU or other products is not authorized to use. Any individual, organization or company which infringes our company's intellectual property rights will be Disabled and stopped by our company through any legal actions, and our company will claim the lost and required for compensation of any damage to the company.

* The name of Cmsemicon Limited and logo are both trademarks of our company.

* Our company preserve the rights to further elaborate on the improvements about products' function, reliability and design in this manual. However, our company is not responsible for any usage about this manual. The applications and their purposes in this manual are just for clarification, our company does not guarantee that these applications are feasible without further improvements and changes, and our company does not recommend any usage of the products in areas where people's safety is endangered during accident. Our company's products are not authorized to be used for life-saving or life support devices and systems.our company has the right to change or improve the product without any prior notification, for latest news, please visit our website: www.mcu.com.cn

Table of Content

CMS80F731x Series	1
Table of Content.....	2
1. Central Processing Unit (CPU)	11
1.1 Reset Vector (0000H).....	11
1.2 BOOT Partition	11
1.3 Accumulator (ACC)	13
1.4 B Register(B).....	13
1.5 Stack Pointer Register (SP).....	13
1.6 Data Pointer Register (DPTR0/DPTR1)	13
1.7 Data Pointer Selection Register (DPS).....	14
1.8 Program Status Register (PSW).....	14
1.9 Program Counter (PC)	15
1.10 Timing Access Register (TA)	15
2. Memory and Register Mapping.....	16
2.1 Program Storage Flash	16
2.2 Non-volatile Data Memory Data FLASH.....	17
2.3 General Purpose Data Memory RAM.....	17
2.4 General External Data Register XRAM	19
2.5 Special Function Register SFR	20
2.6 External Special Function Register XSFR.....	21
3. Reset.....	28
3.1 Power-on Reset.....	28
3.2 External Reset.....	30
3.3 LVR Low-voltage Reset.....	30
3.4 Watchdog Reset.....	31
3.5 Software Reset.....	31
3.6 CONFIG Status Protection Reset.....	32
3.7 Power-on Configuration Monitor Reset	32
4. Clock Structure	33
4.1 System Clock Structure	33
4.2 Related Registers.....	34
4.2.1 Oscillator Control Register CLKDIV	34
4.2.2 System Clock Switching Register SCKSEL.....	34
4.2.3 System Clock Status Register SCKSTAU	35
4.2.4 System Clock Monitor Register SCM	36
4.2.5 Function Clock Control Registers.....	37
4.3 System Clock Switching	38
4.4 System Clock Monitoring.....	39
5. Power Management	40
5.1 Power Management Register PCON.....	40
5.2 Power Supply Monitor Register LVDCON	41
5.3 IDLE Idle Mode.....	41
5.4 STOP Sleep Mode.....	42
5.4.1 Sleep Wakes up	42
5.4.2 Wake-up Wait State.....	42
5.4.3 Sleep Wake-up Time	42
5.4.4 Reset Operation Under Sleep	43

5.4.5	Sleep Power Consumption in Debug Mode.....	43
5.4.6	Example of a Sleep Mode Application.....	43
6.	Interrupt.....	44
6.1	Interrupt Overview.....	44
6.2	External Interrupts.....	45
6.2.1	INT0/INT1 Interrupt.....	45
6.2.2	GPIO Interrupt.....	45
6.3	Interrupt With Sleep Wake-up.....	45
6.4	Interrupt Register.....	46
6.4.1	Interrupt Mask Registers.....	46
6.4.1.1	Interrupt Mask Register IE.....	46
6.4.1.2	Interrupt Mask Register EIE2.....	47
6.4.1.3	Timer2 Interrupt Mask Register T2IE.....	47
6.4.1.4	P0 Interrupt Control Register P0EXTIE.....	48
6.4.1.5	Port P1 Interrupt Control Register P1EXTIE.....	48
6.4.1.6	P2 Interrupt Control Register P2EXTIE.....	48
6.4.1.7	P5 Interrupt Control Register P5EXTIE.....	49
6.4.2	Interrupt Priority Controls the Register.....	50
6.4.2.1	Interrupt Priority Control Register IP.....	50
6.4.2.2	Interrupt Priority Control Register EIP1.....	50
6.4.2.3	Interrupt Priority Control Register EIP2.....	51
6.4.2.4	Interrupt Priority Control Register EIP3.....	52
6.4.3	Interrupt Flag Bit Register.....	53
6.4.3.1	Timer0/1, INT0/1 Interrupt Flag Bit Register TCON.....	53
6.4.3.2	Timer2 Interrupt Flag Bit Register T2IF.....	53
6.4.3.3	Peripheral Interrupt Flag Bit Register EIF2.....	54
6.4.3.4	SPI Interrupt Flag Bit Register SPSR.....	55
6.4.3.5	I2C Master Mode Interrupt Flag Registers I2CMCR/I2CMSR.....	55
6.4.3.6	I2C Slave Mode Status Register I2CSSR.....	56
6.4.3.7	UART Control Register SCOn.....	56
6.4.3.8	P0 port Interrupt Flag Register P0EXTIF.....	57
6.4.3.9	Port P1 Interrupt Flag Register P1EXTIF.....	57
6.4.3.10	P2 Port Interrupt Flag Bit Register P2EXTIF.....	57
6.4.3.11	P5 Port Interrupt Flag Bit Register P5EXTIF.....	57
6.4.4	The Clear Operation For the Interrupt Flag Bit.....	58
6.4.5	Special Interrupt Flag Bits in Debug Mode.....	59
7.	I/O Port.....	60
7.1	GPIO Function.....	60
7.1.1	PORTx Data Register Px.....	60
7.1.2	PORTx Direction Register PxTRIS.....	60
7.1.3	PORTx Open-drain Control Register PxOD.....	61
7.1.4	PORTx pull-up Resistor Control Register PxUP.....	61
7.1.5	PORTx Pull-down Resistor Control Register PxRD.....	61
7.1.6	PORTx Slope Control Register PxSR.....	62
7.1.7	The PORTx Data Input Selects Register PxDS.....	62
7.2	Multiplexed Functions.....	63
7.2.1	Port Multiplexing Feature Table.....	63
7.2.2	Port Multiplexing Feature Configuration Register.....	65
7.2.3	The Port Input Function Allocation Registers.....	65
7.2.4	Communication Input Function Allocation Registers.....	67
7.2.5	Port External Interrupt Control Registers.....	68

7.2.6	Multiplexing Features Application Notes	68
8.	Watchdog Timer (WDT)	70
8.1	Overview	70
8.2	Related Registers.....	70
8.2.1	Watchdog Control Register WDCON	70
8.2.2	Watchdog Overflow Control Register CKCON	72
8.3	WDT Interrupt.....	73
8.3.1	Interrupt Mask Register EIE2	73
8.3.2	Interrupt Priority Control Register EIP2	74
9.	Timer Counter 0/1 (Timer0/1)	75
9.1	Overview	75
9.2	Related Registers.....	76
9.2.1	Timer0/1 Mode Register TMOD	76
9.2.2	Timer0/1 Control Register TCON	77
9.2.3	Timer0 Data Register Low Bit TL0	78
9.2.4	Timer0 Data Register High Bit TH0	78
9.2.5	Timer1 Data Register Low Bit TL1	78
9.2.6	Timer1 Data Register High TH1	78
9.2.7	Function Clock Control Register CKCON.....	79
9.3	Timer0/1 Interrupt.....	80
9.3.1	Interrupt Mask Register IE.....	80
9.3.2	Interrupt Priority Control Register IP	81
9.3.3	Timer0/1, INT0/1 Interrupt Flag Bit Register TCON.....	82
9.4	Timer0 Working Mode	83
9.4.1	T0 - Mode 0 (13-bit Timing/Counting Mode).....	83
9.4.2	T0 - Mode 1 (16-bit Timing/Counting Mode).....	83
9.4.3	T0 - Mode 2 (8-bit Auto-reload Timing/Counting Mode)	84
9.4.4	T0 - Mode 3 (Two Separate 8-bit Timers/Counters)	84
9.5	Timer1 Working Mode	85
9.5.1	T1 - Mode 0 (13-bit Timing/Counting Mode).....	85
9.5.2	T1 - Mode 1 (16-bit Timing/Counting Mode).....	85
9.5.3	T1 - Mode 2 (8-bit Auto Reload Timing/Counting Mode)	86
9.5.4	T1 - Mode 3 (Stop Count).....	86
10.	Timer Counter 2 (Timer2)	87
10.1	Overview	87
10.2	Related Registers.....	88
10.2.1	Timer2 Control Register T2CON	88
10.2.2	Timer2 Data Register Low bit TL2	88
10.2.3	Timer2 Data Register High TH2	89
10.2.4	Timer2 Compare/Capture/Auto Reload Register Low Bit RLDL	89
10.2.5	Timer2 Compare/Capture/Auto Reload Register High Bit RLDH	89
10.2.6	Timer2 Compares/Captures Channel 1 Register Low Bit CCL1.....	89
10.2.7	Timer2 Compares/Captures Channel 1 Register High Bit CCH1	89
10.2.8	Timer2 Compares/Captures Channel 2 Register Low-bit CCL2.....	90
10.2.9	Timer2 Compares/Captures Channel 2 Register High-bit CCH2	90
10.2.10	Timer2 Compares/Captures Channel 3 Register Low-bit CCL3.....	90
10.2.11	Timer2 Compares/Captures Channel 3 Register High-bit CCH3	90
10.2.12	Timer2 Compares the Capture Control Register CCEN	91
10.3	Timer2 Interrupts	92
10.3.1	Interrupt Correlation Registers	92
10.3.1.1	Interrupt Mask Register IE	92

10.3.1.2	Timer2 Interrupt Mask Register T2IE	93
10.3.1.3	Interrupt Priority Control Register IP	93
10.3.1.4	Timer2 Interrupt Flag Bit Register T2IF	94
10.3.2	Timer Interrupts	95
10.3.3	Externally Triggered Interrupts	95
10.3.4	Compare Interrupts	95
10.3.5	Capture Interrupts	95
10.4	Timer2 Feature Description	96
10.4.1	Timing Mode	96
10.4.2	Reload Mode	96
10.4.3	Gated Timing Mode	97
10.4.4	Event Counting Mode	97
10.4.5	Compare Mode	98
10.4.5.1	Compare Mode 0	98
10.4.5.2	Comparison Mode 1	99
10.4.6	Capture Mode	100
10.4.6.1	Capture Mode 0	100
10.4.6.2	Capture Mode 1	101
11.	Timer 3/4 (Timer3/4)	102
11.1	Overview	102
11.2	Related Registers	102
11.2.1	Timer3/4 Control Register T34MOD	102
11.2.2	Timer3 Data Register Low Bit TL3	103
11.2.3	Timer3 Data Register High Bit TH3	103
11.2.4	Timer4 Data Register Low Bit TL4	103
11.2.5	Timer4 Data Register High Bit TH4	103
11.3	Timer3/4 Interrupt	104
11.3.1	Interrupt Mask Register EIE2	104
11.3.2	Interrupt Priority Control Register EIP2	105
11.3.3	Peripheral Interrupt Flag Bit Register EIF2	106
11.4	Timer3 Working Mode	107
11.4.1	T3 - Mode 0 (13-bit Timing Mode)	107
11.4.2	T3 - Mode 1 (16-bit Timing Mode)	107
11.4.3	T3 - Mode 2 (8-bit Auto Reload Timing Mode)	108
11.4.4	T3 - Mode 3 (Two Separate 8-bit Timers)	108
11.5	Timer4 Working Mode	109
11.5.1	T4 - Mode 0 (13-bit Timing Mode)	109
11.5.2	T4 - Mode 1 (16-bit Timing Mode)	109
11.5.3	T4 - Mode 2 (8-bit Auto Reload Timing Mode)	110
11.5.4	T4 - Mode 3 (Stop Count)	110
12.	LSE Timer(LSE_Timer)	111
12.1	Overview	111
12.2	Related Registers	111
12.2.1	LSE Timer Data Register Low 8 Bit LSECRL	111
12.2.2	LSE Timer Data Registers are 8 Bits High LSECRH	111
12.2.3	LSE Timer Control Register LSECON	112
12.3	Interrupt With Sleep Wake-up	113
12.4	Feature Description	114
13.	Wake-up Timer (WUT)	115
13.1	Overview	115
13.2	Related Registers	115

13.2.1	WUTCRH Register	115
13.2.2	WUTCRL Register.....	115
13.3	Feature Description	116
14.	Baud Rate Timer (BRT).....	117
14.1	Overview	117
14.2	Related Registers.....	117
14.2.1	BRT Module Control Register BRTCon	117
14.2.2	The BRT Timer Data is Loaded With a Low 8-bit Register BRTDL	117
14.2.3	The BRT Timer Data is Loaded With a High 8-bit Register BRTDH	117
14.3	Feature Description	118
15.	Cyclic Redundancy Check Unit (CRC).....	119
15.1	Overview	119
15.2	Related Registers.....	119
15.2.1	CRC Data Input Register CRCHIN.....	119
15.2.2	The CRC Operation Results in a Low 8-bit Data Register, CRCDL	119
15.2.3	The CRC Operation Results in a High 8-bit Data Register With CRCDH.....	119
15.3	Feature Description	120
16.	Buzzer Driver (BUZZER).....	121
16.1	Overview	121
16.2	Related Registers.....	121
16.2.1	BUZZER Control Register BUZCON.....	121
16.2.2	BUZZER Frequency Control Register BUZDIV	121
16.3	Feature Description	122
17.	PWM Module	123
17.1	Overview	123
17.2	Characteristic	123
17.3	Port Configuration	123
17.4	Feature Description	124
17.4.1	Functional Block Diagram	124
17.4.2	Edge Alignment	125
17.4.3	Complementary Model	126
17.4.4	Synchronous Mode	127
17.5	PWM-related Registers	128
17.5.1	PWM Control Register PWMCON.....	128
17.5.2	PWM Output Enable Control Register PWMOE.....	129
17.5.3	PWM0/1 Clock Prescale Control Register PWM01PSC.....	129
17.5.4	PWM2/3 Clock Prescale Control Register PWM23PSC.....	129
17.5.5	PWM4/5 Clock Prescale Control Register PWM45PSC.....	130
17.5.6	PWM Clock Divide Control Register PWMnDIV (n=0-5)	130
17.5.7	PWM Data Loading Enable Control Register PWMLOADEN.....	130
17.5.8	PWM Output Polarity Control Register PWMPINV	131
17.5.9	PWM Counter Mode Control Register PWMCNTM.....	131
17.5.10	PWM Counter Enable Control Register PWMCNTE	131
17.5.11	PWM Counter Mode Control Register PWMCNTCLR.....	132
17.5.12	PWM Cycle Data Register Low 8 Bits PWMPnL (n=0-5).....	132
17.5.13	PWM Cycle Data Register High 8 Bits PWMPnH (n=0-5).....	132
17.5.14	PWM Compare Data Register Low 8 Bits PWMDnL (n=0-5).....	132
17.5.15	PWM Compare Data Register High 8 BitS PWMDnH (n=0-5)	132
17.5.16	PWM Dead-zone Enable Control Register PWMDTE	133
17.5.17	PWM0/1 Dead-zone Delay Data Register PWM01DT	133

17.5.18 PWM2/3 Dead-zone Delay Data Register PWM23DT	133
17.5.19 PWM4/5 Dead-zone Delay Data Register PWM45DT	133
17.6 PWM Interrupt	134
17.6.1 Interrupt Mask Register EIE2	134
17.6.2 Interrupt Priority Control Register EIP2	135
17.6.3 PWM Zero Interrupt Mask Register PWMZIE	135
17.6.4 PWM Down Compare Interrupt Mask Register PWMDIE	136
17.6.5 PWM Zero Interrupt Flag Register PWMZIF	136
17.6.6 PWM Down Compare Interrupt Flag Register PWMDIF	136
18. Hardware LED Matrix Driver	137
18.1 Overview	137
18.2 Characteristic	137
18.3 Related Registers	137
18.3.1 LED Drive Mode Select Register LEDMODE	137
18.3.2 LED Control Register LEDCON	138
18.3.3 LED Clock Prescale Data Register Low 8 Bit LEDCLKL	138
18.3.4 LED Clock Prescale Data Register High 8 Bit LEDCLKH	139
18.3.5 COM Port Valid Time Selection Register LEDCOMTIME	139
18.3.6 COM Port Enable Control Register LEDCOMEN	139
18.3.7 SEG Port Enable Control Register LEDSEGEN0	139
18.3.8 SEG Port Enable Control Register LEDSEGEN1	140
18.3.9 COM0 Corresponding SEG Data Register LEDC0DATAn (n=0-1)	140
18.3.10 COM1 Corresponding SEG Data Register LEDC1DATAn (n=0-1)	140
18.3.11 COM2 Corresponding SEG Data Register LEDC2DATAn (n=0-1)	140
18.3.12 COM3 Corresponding SEG Data Register LEDC3DATAn (n=0-1)	141
18.3.13 COM4 Corresponding SEG Data Register LEDC4DATAn (n=0-1)	141
18.3.14 COM5 Corresponding SEG Data Register LEDC5DATAn (n=0-1)	141
18.3.15 COM6 Corresponding SEG Data Register LEDC6DATAn (n=0-1)	141
18.3.16 COM7 Corresponding SEG Data Register LEDC7DATAn (n=0-1)	142
18.3.17 P04-P07 Drive Current Control Register LEDSDRP0H	142
18.3.18 P10-P13 Drive Current Control Register LEDSDRP1L	142
18.3.19 P14-P17 Drive Current Control Register LEDSDRP1H	143
18.3.20 P20-P23 Drive Current Control Register LEDSDRP2L	143
18.3.21 LED Pin Drive Enable Low 8-bit LEDENL	144
18.3.22 LED Pin Drive Enable High 8-bit LEDENH	146
18.3.23 COM Port Sink Current Selection Register P0DR	148
18.4 LED Driver Output Waveform	149
19. Hardware LED Dot Matrix Driver	150
19.1 Overview	150
19.2 Characteristic	150
19.3 Feature Description	151
19.4 Related Registers	156
19.4.1 LED Drive Mode Select Register LEDMODE	156
19.4.2 LED Dot Matrix Drive Controller LEDCON1	156
19.4.3 LED Dot Matrix Drive Clock Prescale Register Low 8 Bit LEDCLKL1	157
19.4.4 LED Dot Matrix Drive Clock Prescale Register High 8 Bits LEDCLKH1	157
19.4.5 LED Dot Matrix Drive First Stage Configuration Register Higher 8 Bits scan1WH	157
19.4.6 LED Dot Matrix Drive First Stage Configuration Register Low 8 Bits SCAN1WL	157
19.4.7 LED Dot Matrix Drives Second Stage Configuration Register High 8 Bits scan2WH	158
19.4.8 LED Dot Matrix Drive Second Stage Configuration Register Low 8 Bits SCAN2WL	158
19.4.9 LED Dot Matrix Drive Display Data Register LEDnDATA (n=0-7)	158

19.4.10 LED Dot Matrix Drive Cycle Select Register LEDnSEL (n=0-7)	159
19.4.11 P00-P03 Drive Current Control Register LEDSDRP0L	159
19.4.12 P04-P07 Drive Current Control Register LEDSDRP0H.....	160
19.4.13 LED Pin Drive Enable Low 8-bit LEDENL	160
19.4.14 LED Pin Drive Enable High 8-bit LEDENH.....	162
19.5 LED Dot Matrix Drive Interrupt	164
19.5.1 LED Dot Matrix Drive Status Register LEDSTATUS.....	164
19.5.2 Interrupt Priority Control Register EIP2	164
20. SPI Module	165
20.1 Overview	165
20.2 SPI Port Configuration.....	166
20.3 SPI Hardware Description	167
20.4 SPI-related Registers	169
20.4.1 SPI Control Register SPCR.....	169
20.4.2 SPI Data Register SPDR	169
20.4.3 SPI Device Select Control Register SSCR.....	170
20.4.4 SPI Status Register SPSR	170
20.5 SPI Master Mode.....	171
20.5.1 Write Conflict Error.....	172
20.6 SPI Slave Mode.....	173
20.6.1 Address Error.....	173
20.6.2 Write Conflict Error.....	173
20.7 SPI Clock Control Logic	175
20.7.1 SPI Clock Phase and Polarity Control.....	175
20.7.2 SPI Transfer Format.....	175
20.7.3 CPHA=0 Transfer Format.....	175
20.7.4 CPHA=1 Transfer Format.....	176
20.8 SPI Data Transfer.....	177
20.8.1 SPI Transfer Starts.....	177
20.8.2 SPI Transfer Ends.....	177
20.9 SPI Timing Diagram	178
20.9.1 Master Mode Transmission	178
20.9.2 Slave Mode Transmission	178
20.10 SPI Interrupt.....	179
20.10.1 Interrupt Mask Register EIE2	179
20.10.2 Interrupt Priority Control Register EIP2	180
20.10.3 Peripheral Interrupt Flag Bit Register EIF2.....	181
21. I2C Module.....	182
21.1 Overview	182
21.2 I2C Port Configuration.....	183
21.3 I2C Master Mode.....	183
21.3.1 I2C Master Mode Timing Cycle Register.....	184
21.3.2 I2C Master Mode Control and Status Registers	185
21.3.3 I2C Slave Address Register	188
21.3.4 I2C Master Mode Transmit and Receive Data Registers	188
21.4 I2C Slave Mode.....	189
21.4.1 I2C Own Address Register I2CSADR	189
21.4.2 I2C Slave Mode Control and Status Registers I2CSCR/I2CSSR	189
21.4.3 I2C Slave Mode Transmit and Receive Buffer Registers I2CSBUF	190
21.5 I2C Interrupt	191
21.5.1 Interrupt Mask Register EIE2	191

21.5.2	Interrupt Priority Control Register EIP2	192
21.5.3	Peripheral Interrupt Flag Bit Register EIF2.....	193
21.6	I2C Slave Mode Transmission Mode	194
21.6.1	Single Receive	194
21.6.2	Single Send.....	195
21.6.3	Continuous Reception.....	196
21.6.4	Continuous Sending.....	197
22.	UARTn Module	198
22.1	Overview	198
22.2	UARTn Port Configuration.....	198
22.3	UARTn Baud Rate.....	199
22.3.1	Baud Rate Clock Source	199
22.3.2	Baud Rate Calculation	199
22.3.3	Baud Rate Error	200
22.4	UARTn Register	202
22.4.1	UART0/1 Baud Rate Selection Register FUNCCR	202
22.4.2	UARTn Buffer Register SBUFn	202
22.4.3	UART Control Register SCONn	203
22.4.4	PCON Registers.....	204
22.5	UARTn Interrupt.....	205
22.5.1	Interrupt Mask Register IE.....	205
22.5.2	Interrupt Priority Control Register IP	206
22.6	UARTn Mode.....	207
22.6.1	Mode 0 - Synchronous Mode	207
22.6.2	Mode 1-8 Bit Asynchronous Mode (Variable Baud Rate)	207
22.6.3	Mode 2-9 Bit Asynchronous Mode (Fixed Baud Rate)	208
22.6.4	Mode 3-9 Bit Asynchronous Mode (Variable Baud Rate)	208
23.	Analog-to-digital Converter (ADC)	209
23.1	Overview	209
23.2	ADC Configuration	210
23.2.1	Port Configuration	210
23.2.2	Channel Selection	210
23.2.3	ADC Reference Voltage	210
23.2.4	Convert the Clock.....	211
23.2.5	Result Format.....	211
23.3	The ADC Hardware Trigger Start.....	212
23.3.1	The External Port Edge Triggers the ADC.....	212
23.3.2	PWM Triggers the ADC	212
23.3.3	Hardware Trigger Start Delay.....	212
23.4	ADC Results Comparison	213
23.5	How the ADC Works.....	213
23.5.1	Start the Conversion	213
23.5.2	Complete the Conversion.....	213
23.5.3	Terminate the Conversion	213
23.5.4	A/D Conversion Steps.....	213
23.5.5	Go to Sleep During the Conversion Process.....	214
23.6	Related Registers.....	215
23.6.1	AD Control Register ADCON0.....	215
23.6.2	AD Control Register ADCON1.....	216
23.6.3	AD Control Register ADCON2.....	216
23.6.4	AD Channel Selection Register ADCCHS	217

23.6.5	AD Comparator Control Register ADCPC	218
23.6.6	AD Hardware Trigger Delay Data Register ADDLYL	218
23.6.7	AD Data Register High ADRESH, ADFM=0 (Left Aligned)	218
23.6.8	AD Data Register Low ADRESL, ADFM=0 (Left Aligned).....	218
23.6.9	AD Data Register High ADRESH, ADFM=1 (Right-aligned).....	219
23.6.10	AD Data Register Low ADRESL, ADFM = 1 (Right-aligned).....	219
23.6.11	AD Comparator Data Register ADCCMPH.....	219
23.6.12	AD Comparator Data Register ADCOP	219
23.6.13	AD Reference Voltage Control Register	220
23.7	ADC Interrupt	221
23.7.1	Interrupt Mask Register EIE2	221
23.7.2	Interrupt Priority Control Register EIP2	222
23.7.3	Peripheral Interrupt Flag Bit Register EIF2.....	223
24.	Touch Module (TOUCH).....	224
24.1	Touch Module Usage Considerations	224
25.	Flash Memory.....	225
25.1	Overview	225
25.2	Related Registers.....	226
25.2.1	Flash Protect Lock Register MLOCK	226
25.2.2	FLASH Memory Data Register MDATA.....	226
25.2.3	FLASH Memory Address Register MADRL	226
25.2.4	FLASH Memory Address Register MADRH	226
25.2.5	Program CRC Operation Result Data Register Lower 8-bit PCRCDL.....	227
25.2.6	Program CRC Operation Result Data Register Higher 8-bit PCRCDH	227
25.2.7	FLASH Memory Control Register MCTRL	227
25.3	Feature Description	228
26.	Unique ID (UID)	229
26.1	Overview	229
26.2	UID Register Description	229
27.	User Configuration	232
28.	In-circuit Programming and Debugging	234
28.1	Online Programming Mode.....	234
28.2	Online Debug Mode	235
29.	Instruction Description.....	236
29.1	Symbol Description	236
29.2	List of Instructions	237
30.	Version Revision Notes	240

1. Central Processing Unit (CPU)

This series is a microcontroller with 8-bit 8051 frame structure. The CPU is the core component of the microcontroller, which is composed of arithmetic units, controllers, and special register groups. The arithmetic unit module mainly implements data arithmetic and logic operations, bit variable processing and data transfer operations; the controller module mainly decodes instructions, and then sends out various control signals; the special register group is mainly used to indicate the memory address of the current instruction to be executed, store the operand and indicate the state after the instruction is executed. The special register group mainly includes accumulator ACC, general register B, stack pointer SP, data pointer DPTR, Program status register PSW, Program counter PC, etc.

1.1 Reset Vector (0000H)

The microcontroller has a word-long system reset vector (0000H), after which the program will restart execution at 0000H and the system registers will revert to their default values. The following program demonstrates how to define a reset vector in FLASH.

Example: Define a reset vector

	ORG	0000H	; System reset vector
	LJMP	START	
	ORG	0010H	; The user program starts
START:			
	...		; User programs
	...		
	END		; The program ends

1.2 BOOT Partition

The size of the program area space is 16K*8Bit, where the program is divided into BOOT area and APROM area, and the BOOT area size is allocated by the user configuration register.

When the chip is powered on, if the program is started from the BOOT area, it needs to be satisfied: the address space allocation method is 1/2/3 (set BOOT_1K/BOOT_2K/BOOT_4K through CONFIG), otherwise the program will be launched from the APROM area.

Take the 1K space in the BOOT area as an example: config configuration BOOT_1K, after the chip is powered on configuration, the program starts running from address 3C00H. If the program needs to switch between the BOOT region and the APROM region, it is necessary to write a 0xAA/0x55 to the BOOT region control register BOOTCON (see register description for details), and then perform a software reset or generate a watchdog reset.

When power-on reset, external reset, voltage reset, bootcon reset value is 0x00, software reset and watchdog reset can not clear the register.

BOOT Control Register (BOOTCON)

F691H	Bit7	Bit6	Bit5	Bit4	Bit3	Bit2	Bit1	Bit0
BOOTCON	D7	D6	D5	D4	D3	D2	D1	D0
R/W	R/W	R/W	R/W	R/W	R/W	R/W	R/W	R/W
Reset value	0	0	0	0	0	0	0	0

Bit7~Bit0 D<7:0>: BOOT zone control bit (this register can only be written when the chip is configured to BOOT_1K/BOOT_2K/BOOT_4K);

0x55= If you switch from the APROM area to the BOOT area, you need to write 0x55 to it, and then perform a software reset or generate a watchdog reset;

0xAA= If you switch from the BOOT area to the APOROM area, you need to write 0xAA to it, and then perform a software reset or generate a watchdog reset;

Other values= Invalid.

For example, after the chip is powered on and booted from the BOOT area, use the software reset method to switch to the APROM area, and the configuration is as follows:

- 1) The BOOTCON register needs to write AAH

```
MOVDPTR,# BOOTCON
MOVE,#0AAH
MOVX@DPTR,A
```

- 2) Perform a software reset

```
MOVTA,#0AAH
MOVTA,#055H
MOVWDCON,#080H
```

For example, use the software reset method to switch from the APROM area to the BOOT area, and configure it as follows:

- 1) The BOOTCON register needs to write 55H

```
MOVDPTR, # BOOTCON
MOVA,#055H
MOVX@DPTR,A
```
- 2) Perform a software reset

```
MOVTA,#0AAH
MOVTA,#055H
MOVWDCON,#080H
```

Note: When the BOOT function is valid, the APROM program needs to ensure that the PC does not overflow (overflow means that the PC is out of the address range of the APROM), and if the PC overflows, the system may run abnormally.

1.3 Accumulator (ACC)

The ALU is an 8Bit wide arithmetic logic unit through which all mathematical and logical operations of the MCU are completed. It can add, subtract, shift and logical operations on data; The ALU also controls the status bits (in the PSW status register) that represent the state of the result of the operation.

The ACC register is an 8Bit register where the results of ALU operations can be stored.

1.4 B Register(B)

The B register is used when using multiplication and division instructions. If the multiplication and division instruction is not used, it can also be used as a universal register.

1.5 Stack Pointer Register (SP)

The SP register points to the address of the stack, and the default value after reset is 0x07, which means that the area of the stack starts at 08H of the RAM address. The value of the SP can be modified, and if the stack region is set to start 0xC0, the value of the SP needs to be set to 0xBF after the system reset.

Operations that affect SP are: instruction PUSH, LCALL, ACALL, POP, RET, RETI, and entering interrupts.

PUSH instructions occupy one byte in the stack, LCALL, ACALL, and interrupt occupy two bytes in the stack, POP instructions release one byte, and RET/RETI instructions free two bytes.

Using the PUSH instruction automatically saves the current value of the operated register to RAM.

1.6 Data Pointer Register (DPTR0/DPTR1)

The data pointer is mainly used in MOVX, MOVC instructions, and its role is to locate the addresses of XRAM and ROM. Inside the chip, there are two data pointer registers DPTR0 and DPTR1, selected by the DPS register.

Each set of pointers includes two 8-bit registers: DPTR0={DPH0,DPL0}; DPTR1={DPH1,DPL1};

For example, the assembly code for operating XRAM is as follows:

MOV	DPTR,#0001H	
MOV	A,#5AH	
MOVX	@DPTR,A	; Write the data in A to XRAM address 0001H

1.7 Data Pointer Selection Register (DPS)

The data pointer selects register DPS

0x86	Bit7	Bit6	Bit5	Bit4	Bit3	Bit2	Bit1	Bit0
DPS	ID1	ID0	TSL	AT	--	--	--	SALT
R/W	R/W	R/W	R/W	R/W	R/W	R/W	R/W	R/W
Reset value	0	0	0	0	0	0	0	0

Bit7~Bit6 ID<1:0>: Subtract/add function selection.

- 00= DPTR0 plus 1 or DPTR1 plus 1;
- 01= DPTR0 minus 1 or DPTR1 plus 1;
- 10= DPTR0 plus 1 or DPTR1 minus 1;
- 11= DPTR0 minus 1 or DPTR1 minus 1.

Bit5 TSL: Flip selection enable;

- 1= After executing the DPTR instruction, the SEL bit is automatically flipped;
- 0= DPTR-related instructions do not affect the SEL bits.

Bit4 AT: Self-addition/subtraction enable bits;

- 1= Allows MOVX @DPTR or MOVC @DPTR instructions to run, perform subtractive/self-addition operations (determined by ID1-ID0).
- 0= DPTR-related directives do not affect DPTR itself.

Bit3~Bit1 -- Reserved, must be 0.

Bit0 SALT: Data pointer selection bit;

- 1= Select DPTR1;
- 0= Select DPTR0.

1.8 Program Status Register (PSW)

Program status register PSW

0xD0	Bit7	Bit6	Bit5	Bit4	Bit3	Bit2	Bit1	Bit0
PSW	CY	AND	F0	RS1	RS0	OV	--	P
R/W	R/W	R/W	R/W	R/W	R/W	R/W	R/W	R
Reset value	0	0	0	0	0	0	0	0

Bit7 CY: Carry marker bits;

- 1= There are carry-ons;
- 0= No carry.

Bit6 AND: Auxiliary carry markers (half-carry markers);

- 1= There are carry-ons;
- 0= No carry.

Bit5 F0: Generic flag bits.

Bit4~Bit3 RS<1:0>: Working register BANK select bit;

- 00= Select Bank0;
- 01= Select Bank1;
- 10= Select Bank2;
- 11= Select Bank3.

Bit2 OV: Overflow flag bit;

- 1= There is an overflow in arithmetic or logical operations;
- 0= There is no overflow of arithmetic or logical operations.

Bit1 -- Reserved, must be 0.

Bit0 P: Check bit;

- 1= The highest level of the result occurred.
- 0= The highest bit of the result did not occur carry.

1.9 Program Counter (PC)

The program counter (PC) controls the order of instruction execution in the program memory FLASH, it can address the entire flash range, after obtaining the instruction code, the program counter (PC) will automatically add one, pointing to the address of the next instruction code. However, when performing operations such as jumps, conditional jumps, subroutine calls, initial resets, interrupts, interrupt returns, subprogram returns, etc., the PC loads the address associated with the instruction instead of the address of the next instruction.

When a conditional jump instruction is encountered and the jump condition is met, the next instruction read during the execution of the current instruction will be discarded and an empty instruction operation cycle will be inserted before the correct instruction can be obtained. Instead, the next instruction is executed sequentially.

1.10 Timing Access Register (TA)

Timing access register TA

0x96	Bit7	Bit6	Bit5	Bit4	Bit3	Bit2	Bit1	Bit0
HE	TA7	TA6	TA5	TA4	TA3	TA2	TA1	TA0
R/W	R/W	R/W	R/W	R/W	R/W	R/W	R/W	R/W
Reset value	0	0	0	0	0	0	0	0

Bit7~Bit0

TA<7:0>: Timing access control bits.

Some protected registers must be written to the TA before they can be performed as follows.

```
MOV HE, #0AAH
```

```
MOV TA, #055H
```

No other instructions can be inserted in the middle, and this sequence needs to be re-executed when modified again.

Protected registers: WDCON, CLKDIV, SCKSEL, MLOCK.

2. Memory and Register Mapping

This series of Microcontrollers has the following types of memory:

- ◆ Up to 16 KB of FLASH program memory (shared by APROM and BOOT).
- ◆ Non-volatile data memory (Data FLASH) up to 1 KB.
- ◆ Up to 256B of general-purpose internal data memory (RAM).
- ◆ General External Data Memory (XRAM) up to 1 KB.
- ◆ Special function register SFR.
- ◆ External special function register XSFR.

2.1 Program Storage Flash

Program memory FLASH is used to store source program and table data, and the program counter PC is used as an address pointer. The PC is a 16-bit program counter, so the address space that can be addressed is 64KB, but this chip only has 16K bytes of program storage space.

The FLASH space allocation block diagram is shown in the following figure:

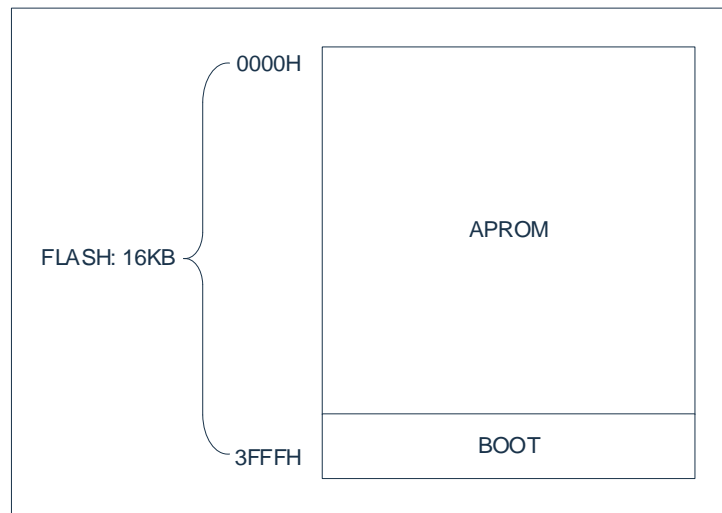

After the chip is reset, the CPU starts executing from 0000H. Each interrupt is assigned a fixed address in the program memory, and the interrupt causes the CPU to jump to that address to start executing the service program.

For example, external interrupt 1, which is assigned the address 0013H, if external interrupt 1 is used, its service program must start at the 0013H location. If the interrupt is not used, its service address is used as a normal program store address.

2.2 Non-volatile Data Memory Data FLASH

The non-volatile data memory Data FLASH can be used to store important data such as constant data, calibration data, protection safety-related information, etc. The data stored in this area has the characteristic that the data is not lost in the event of a chip power outage or a sudden or unexpected power outage. The Data FLASH space allocation block diagram is shown in the following figure:

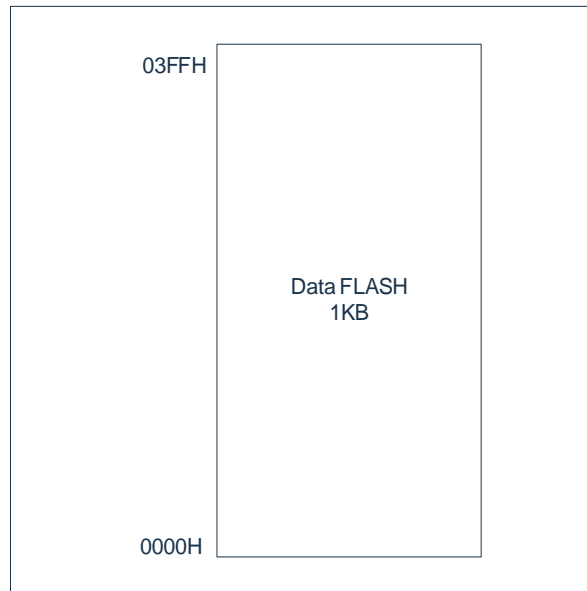

The read, write and erase operations of the Data FLASH memory are implemented through the FLASH control interface.

2.3 General Purpose Data Memory RAM

The internal data memory is divided into three parts: low 128Bytes, high 128Bytes, and special function register SFR. The RAM space allocation block diagram is shown in the following figure:

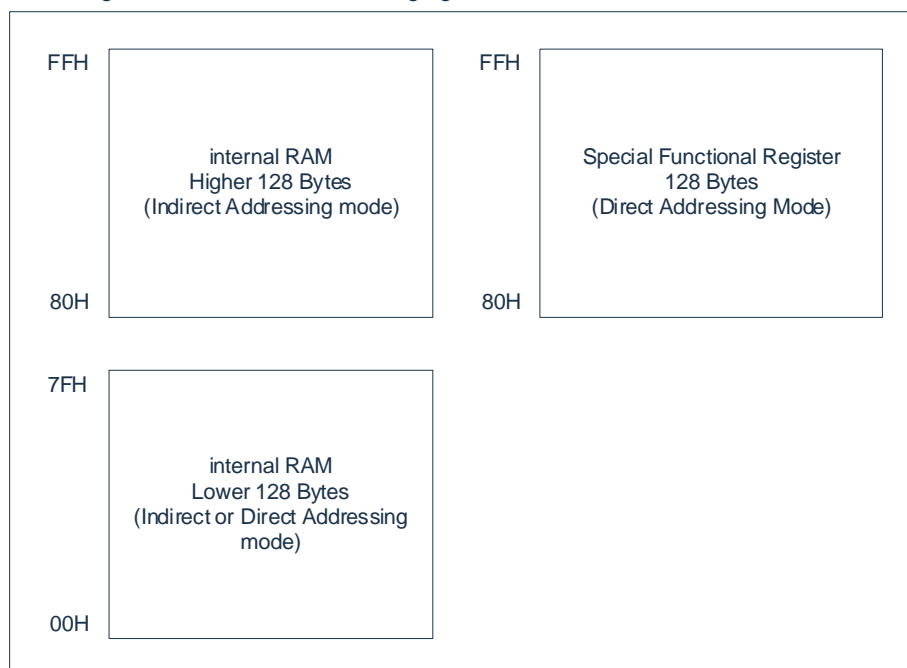

The high 128 Bytes shown above and SFR occupy the same area (80H to FFH), but they are independent. Storage spaces with direct addressing above 7FH (SFR) and indirect addressing above 7FH (128 Bytes high) go into different storage spaces.

The low 128Bytes spatial register allocation shown in the figure above is shown in the figure below. The lowest 32 bytes (00H~1FH) make up 4 register groups, each group of 8 storage units, with R0~R7 as the unit number, used to save operands and intermediate results. After reset, the 0 group is selected by default, and if a different register group is selected, it is decided by changing the program state. The 16 Bytes (20H to 2FH) behind the register bank form a bit-addressable storage space, and the RAM units in this area can operate either byte-by-byte or directly on each bit in the unit. With the remaining 80 storage units (30H to 7FH), users can set stack areas and store intermediate data.

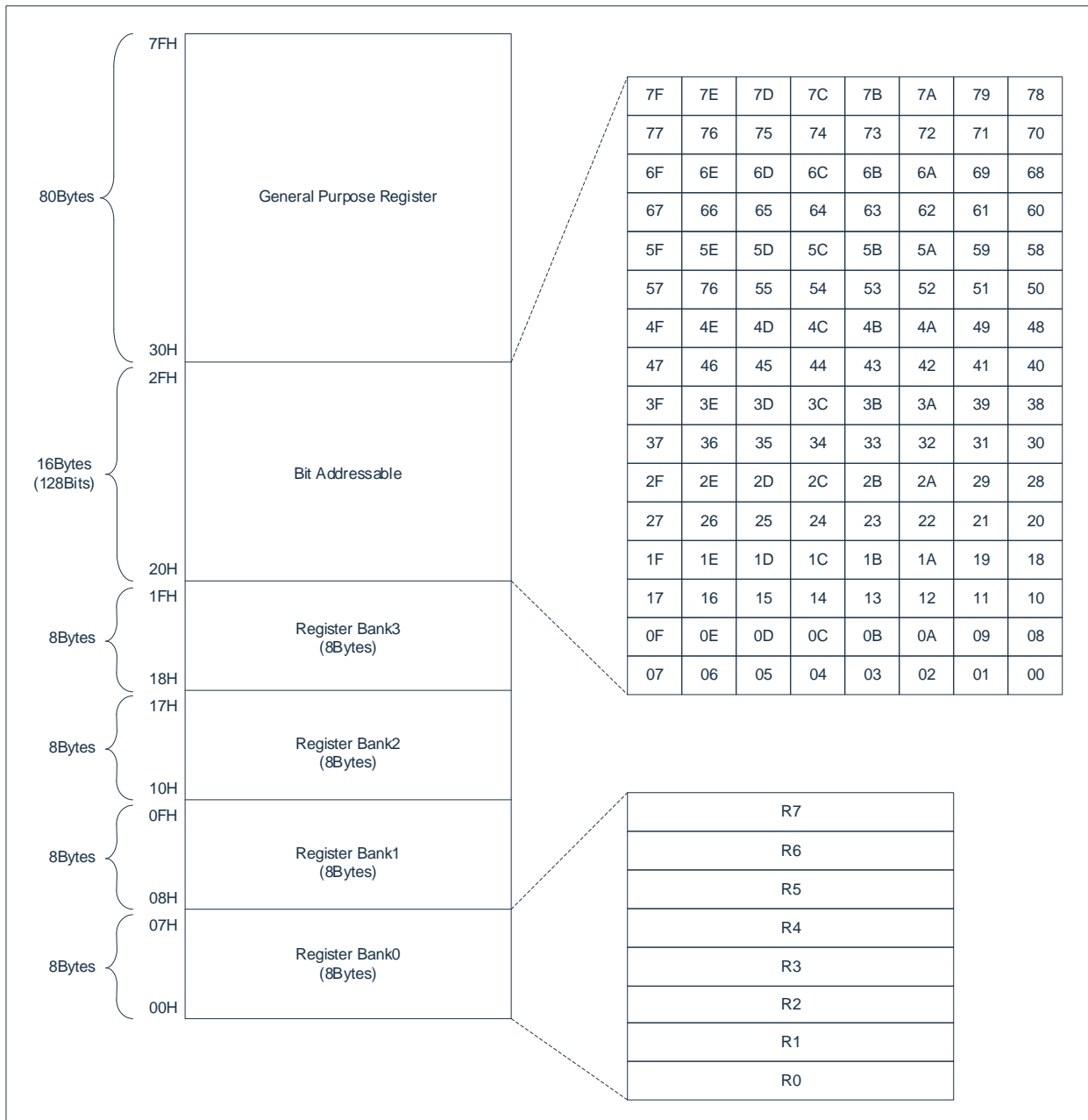

2.4 General External Data Register XRAM

There is a maximum 1KB XRAM area inside the chip, this area is not connected to FLASH/RAM, and the XRAM space allocation block diagram is shown in the following figure:

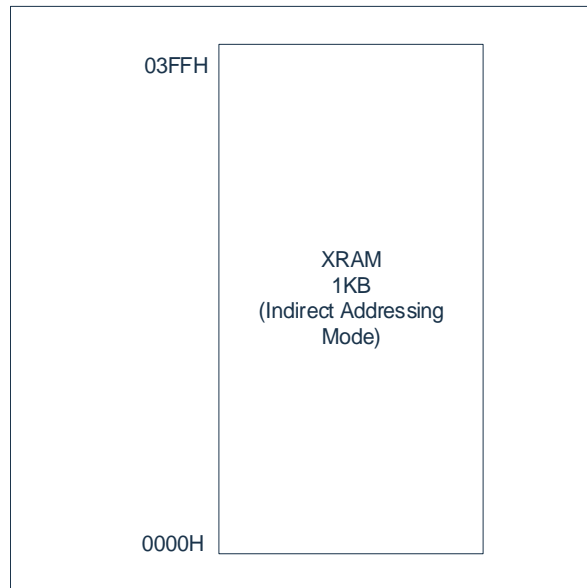

XRAM/XSFR spatial access operates through DPTR data pointers, which consist of two sets of pointers: DPTR0, DPTR1, selected by the DPS registers. For example, through movx indirection operations, the assembly code is as follows:

MOV	R0.#01H	
MOV	A,#5AH	
MOVX	@R0,A	; Write the data in A to XRAM address 01H, the high 8-bit address is determined by DPH0/1

After target--> Memory Model is set to Large in Keil51, the C compiler will take XRAM as the variable address. XRAM/XSFR operations are generally performed with DPTR.

2.5 Special Function Register SFR

Special function registers refer to a set of registers with special purposes, essentially some on-chip RAM units with special functions, discretely distributed in the address range of 80H to FFH. Users can byte access them through direct addressing instructions, and addresses four bits lower than 0000 or 1000 can be addressed bitwise, such as P0, TCON, P1.

The register table is as follows:

	0/8	1/9	2/A	3/B	4/C	5/D	6/E	7/F
0xF8	--	PCRCDL	PCRCDH	MLOCK	MADRL	MADRH	MDATA	MCTRL
0xF0	B	I2CSADR	I2CSCR	I2CSBUF	I2CMSA	I2CMCR	I2CMBUF	I2CMTP
0xE8	--	ADCON2	SCON1	SBUF1	SPCR	SPSR	SPDR	SSCR
0xE0	ACC	--	TL4	TH4	--	--	--	--
0xD8	P5	ADCCHS	TL3	TH3	ADRESL	ADRESH	ADCON1	ADCON0
0xD0	PSW	ADCMPC	T34MOD	ADDLYL	ADCMPL	ADCMPLH	SCKSEL	SCKSTAU
0xC8	T2CON	T2IF	RLDL	RLDH	TL2	TH2	CCEN	T2IE
0xC0	--	--	CCL1	CCH1	CCL2	CCH2	CCL3	CCH3
0xB8	IP	EIP1	EIP2	EIP3	WUTCRL	WUTCRLH	BUZDIV	BUZCON
0xB0	--	--	EIF2	--	P0EXTIF	P1EXTIF	P2EXTIF	--
0xA8	IE	--	EIE2	--	P0EXTIE	P1EXTIE	P2EXTIE	--
0xA0	P2	P1TRIS	P2TRIS	--	--	P5TRIS	--	P5EXTIF
0x98	SCON0	SBUF0	P0TRIS	--	P5EXTIE	--	--	--
0x90	P1	FUNCCR	--	--	--	--	HE	WDCON
0x88	TCON	TMOD	TL0	TL1	TH0	TH1	CKCON	CLKDIV
0x80	P0	SP	DPL0	DPH0	DPL1	DPH1	DPS	PCON

2.6 External Special Function Register XSFR

XSFR is a special register shared by the addressing space and XRAM, mainly including: port control registers, other function control registers. Its addressing range is shown in the following figure:

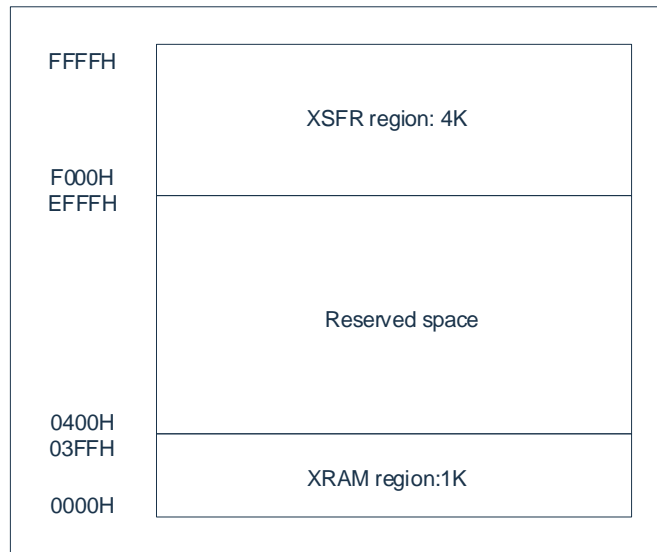

The list of external special function registers is as follows:

address	register	Register description
F000H	P00CFG	P00 port configuration register
F001H	P01CFG	P01 port configuration register
F002H	P02CFG	P02 port configuration register
F003H	P03CFG	P03 port configuration register
F004H	P04CFG	P04 port configuration register
F005H	P05CFG	P05 port configuration register
F006H	P06CFG	P06 port configuration register
F007H	P07CFG	P07 port configuration register
F009H	P0OD	P0-port open-drain control register
F00AH	P0UP	P0 port pull-up resistor control register
F00BH	P0RD	P0 port pull-down resistor control register
F00CH	P0DR	P0 ports drive current selection registers
F00DH	P0SR	P0 port slope control register
F00EH	P0DS	P0 port data input select register
--	--	--
F010H	P10CFG	P10 port configuration register
F011H	P11CFG	P11 port configuration register
F012H	P12CFG	P12 port configuration register
F013H	P13CFG	P13 port configuration register
F014H	P14CFG	P14 port configuration register
F015H	P15CFG	P15 port configuration register
F016H	P16CFG	P16 port configuration register
F017H	P17CFG	P17 port configuration register
F019H	P1OD	P1 port open-drain control register
F01AH	P1UP	P1 port pull-up resistor control register
F01BH	P1RD	P1 port pull-down resistor control register
--	--	--

address	register	Register description
F01DH	P1SR	P1 port slope control register
F01EH	P1DS	Port P1 data input select register
--	--	--
F020H	P20CFG	P20 port configuration register
F021H	P21CFG	P21 port configuration register
F022H	P22CFG	P22 port configuration register
F023H	P23CFG	P23 port configuration register
--	--	--
F029H	P2OD	P2 port open-drain control register
F02AH	P2UP	P2 port pull-up resistor control register
F02BH	P2RD	P2 port pull-down resistor control register
--	--	--
F02DH	P2SR	P2 port slope control register
F02EH	P2DS	P2 port data input select register
--	--	--
F050H	P50CFG	P50 port configuration register
F051H	P51CFG	P51 port configuration register
F052H	P52CFG	P52 port configuration register
F053H	P53CFG	P53 port configuration register
F054H	P54CFG	P54 port configuration register
F055H	P55CFG	P55 port configuration register
--	--	--
F059H	P5OD	P5-port open-drain control register
F05AH	P5UP	P5 port pull-up resistor control register
F05BH	P5RD	P5 port pull-down resistor control register
F05CH	--	--
F05DH	P5SR	P5 port slope control register
F05EH	P5DS	P5 port data input selection register
--	--	--
F080H	P00EICFG	P00 interrupt control register
F081H	P01EICFG	P01 interrupt control register
F082H	P02EICFG	P02 port interrupt control register
F083H	P03EICFG	P03 interrupt control register
F084H	P04EICFG	P04 port interrupt control register
F085H	P05EICFG	P05 interrupt control register
F086H	P06EICFG	P06 port interrupt control register
F087H	P07EICFG	P07 port interrupt control register
F088H	P10EICFG	P10 port interrupt control register
F089H	P11EICFG	P11 interrupt control register
F08AH	P12EICFG	P12 interrupt control register
F08BH	P13EICFG	P13 port interrupt control register
F08CH	P14EICFG	P14 interrupt control register
F08DH	P15EICFG	P15-port interrupt control register
F08EH	P16EICFG	P16 port interrupt control register
F08FH	P17EICFG	P17 interrupt control register
F090H	P20EICFG	P20 port interrupt control register
F091H	P21EICFG	P21 interrupt control register

address	register	Register description
F092H	P22EICFG	P22 port interrupt control register
F093H	P23EICFG	P23 interrupt control register
--	--	--
F0B8H	P50EICFG	P50 port interrupt control register
F0B9H	P51EICFG	P51 interrupt control register
F0BAH	P52EICFG	P52 port interrupt control register
F0BBH	P53EICFG	P53 port interrupt control register
F0BCH	P54EICFG	P54-port interrupt control register
F0BDH	P55EICFG	P55 port interrupt control register
--	--	--
F0C0H	PS_INT0	External interrupt 0 input port allocation register
F0C1H	PS_INT1	External interrupt 1 input port allocation register
F0C2H	PS_T0	Timer0 external clock input port assignment register
F0C3H	PS_T0G	Timer0 gated input port assignment register
F0C4H	PS_T1	Timer1 external clock input port assignment register
F0C5H	PS_T1G	Timer1 gated input port assignment register
F0C6H	PS_T2	Timer2 external event or gated input port assignment register
F0C7H	PS_T2EX	Timer2 drops along the autoreload input port allocation register
F0C8H	PS_CAP0	The Timer2 input captures channel 0 port assignment registers
F0C9H	PS_CAP1	The Timer2 input captures the channel 1 port assignment register
F0CAH	PS_CAP2	The Timer2 input captures the channel 2 port assignment register
F0CBH	PS_CAP3	The Timer2 input captures the channel 3 port assignment register
F0CCH	PS_ADET	The ADC's external trigger input port allocates registers
--	--	--
F120H	PWMCON	PWM control registers
F121H	PWMOE	PWM output enable register
F122H	PWMPINV	PWM output polarity selection register
F123H	PWM01PSC	PWM0/1 clock prescaler control register
F124H	PWM23PSC	PWM2/3 clock prescale control register
F125H	PWM45PSC	PWM4/5 clock prescale control register
F126H	PWMCNTE	The PWM count starts the control register
F127H	PWMCNTM	PWM counting mode select register
F128H	PWMCNTCLR	PWM counter clears control registers
F129H	PWMLOADEN	PWM loads the enable control register
F12AH	PWM0DIV	PWM0 clock divider control register
F12BH	PWM1DIV	PWM1 clock divider control register
F12CH	PWM2DIV	PWM2 clock divider control register
F12DH	PWM3DIV	PWM3 clock divider control register
F12EH	PWM4DIV	PWM4 clock divider control register
F12FH	PWM5DIV	PWM5 clock divider control register
F130H	PWMP0L	The PWM0 cycle data register is 8 bits lower
F131H	PWMP0H	The PWM0 cycle data register is 8 bits high
F132H	PWMP1L	The PWM1 cycle data register is 8 bits lower
F133H	PWMP1H	The PWM1 cycle data register is 8 bits high

address	register	Register description
F134H	PWMP2L	The PWM2 cycle data register is 8 bits lower
F135H	PWMP2H	The PWM2 cycle data register is 8 bits high
F136H	PWMP3L	The PWM3 cycle data register is 8 bits lower
F137H	PWMP3H	The PWM3 cycle data register is 8 bits high
F138H	PWMP4L	The PWM4 cycle data register is 8 bits lower
F139H	PWMP4H	The PWM4 cycle data register is 8 bits high
F13AH	PWMP5L	The PWM5 cycle data register is 8 bits lower
F13BH	PWMP5H	The PWM5 cycle data register is 8 bits high
--	--	--
F140H	PWMD0L	PWM0 compares 8 bits lower to the data register
F141H	PWMD0H	PWM0 compares the data register 8 bits higher
F142H	PWMD1L	PWM1 compares 8 bits lower to the data register
F143H	PWMD1H	PWM1 compares the data registers 8 bits higher
F144H	PWMD2L	PWM2 compares 8 bits lower to the data register
F145H	PWMD2H	PWM2 compares the data registers 8 bits higher
F146H	PWMD3L	PWM3 compares 8 bits lower to the data register
F147H	PWMD3H	PWM3 compares the data registers 8 bits higher
F148H	PWMD4L	PWM4 compares 8 bits lower to the data register
F149H	PWMD4H	PWM4 compares the data registers 8 bits higher
F14AH	PWMD5L	The PWM5 compares 8 bits lower to the data register
F14BH	PWMD5H	PWM5 compares the data registers 8 bits higher
--	--	--
F160H	PWMDTE	The PWM dead-band enable control register
F161H	PWM01DT	PWM0/1 dead-zone delay data register
F162H	PWM23DT	PWM2/3 dead-zone delay data register
F163H	PWM45DT	PWM4/5 dead-zone delay data register
F164H	PWMMASKE	PWM mask control registers
F165H	PWMMASKD	PWM mask data registers
--	--	--
F169H	PWMZIE	PWM zero-point interrupt mask register
--	--	--
F16BH	PWMDIE	PWM compares the interrupt mask registers downwards
--	--	--
F16DH	PWMZIF	PWM zero-point interrupt flag register
--	--	--
F16FH	PWMDIF	PWM compares the interrupt flag registers downwards
--	--	--
F5C0H	BRTCON	The BRT module controls the registers
F5C1H	BRTDL	The BRT timer data load value is 8 bits lower
F5C2H	BRTDH	The BRT timer data load value is 8 bits higher
--	--	--
F5E0H	UID0	UID<7:0>
F5E1H	UID1	UID<15:8>
F5E2H	UID2	UID<23:16>
F5E3H	UID3	UID<31:24>
F5E4H	UID4	UID<39:32>
F5E5H	UID5	UID<47:40>

address	register	Register description
F5E6H	UID6	UID<55:48>
F5E7H	UID7	UID<63:56>
F5E8H	UID8	UID<71:64>
F5E9H	UID9	UID<79:72>
F5EAH	UID10	UID<87:80>
F5EBH	UID11	UID<95:88>
--	--	--
F690H	LVDCON	Power supply monitor registers
F691H	BOOTCON	BOOT control registers
F692H	ADCLDO	ADC reference voltage control register
--	--	--
F694H	LSECRL	The LSE timer data register is 8 bits lower
F695H	LSECRH	The LSE timer data register is 8 bits high
F696H	LSECON	LSE timer control registers
F697H	XT_SCM	LSE/HSE clock stop detection control register
F698H	PS_SCLK	The SPI clock input port assigns registers
F699H	PS_MOSI	SPI slave input port assignment registers
F69AH	PS_MISO	SPI master input port assignment register
F69BH	PS_NSS	SPI chip-selected input port assignment register
F69CH	PS_SCL	IIC clock input port assignment register
F69DH	PS_SDA	IIC data input port assignment registers
F69EH	PS_RXD1	UART1 data input port assignment register
F69FH	PS_RXD0	UART0 data input port assignment register
--	--	--
F6D0H	KEYCON0	Touch control register 0
F6D1H	KEYCON1	Touch control register 1
F6D2H	KEYCON2	Touch Control Register 2
F6D3H	KEYCON3	Touch Control Register 3
F6D4H	KEYCON4	Touch control register 4
F6D5H	KEYCON5	Touch control register 5
F6D6H	KEYCON6	Touch control register 6
F6D7H	KEYCON7	Touch control register 7
F6D8H	KEYCON8	Touch control register 8
F6D9H	KEYCON9	Touch control register 9
F6DAH	KEYCON10	Touch control register 10
F6DBH	KEYCON11	Touch control register 11
F6DCH	KEYCON12	Touch control register 12
F6DDH	KEYCON13	Touch control register 13
--	--	--
F6E0H	KEYCON16	Touch control register 16
F6E1H	KEYCON17	Touch control register 17
F6E2H	KEYCON18	Touch control register 18
F6E3H	KEYCON19	Touch control register 19
F6E4H	KEYCON20	Touch control register 20
F6E5H	KEYCON21	Touch control register 21
--	--	--
F708H	CRCIN	CRC module data input registers

address	register	Register description
F709H	CRCDL	CRC operation results in a low 8-bit data register
F70AH	CRCDH	The CRC operation results in a high 8-bit data register
--	--	--
F710H	LESDSRP0L	The P00-P03 drive current control register
F711H	LESDSRP0H	The P04-P07 drive current control registers
F712H	LESDSRP1L	The P10-P13 drive current control register
F713H	LESDSRP1H	The P14-P17 drive current control registers
F714H	LESDSRP2L	The P20-P23 drive current control registers
--	--	--
F740H	LEDC0DATA0 LED0DATA	LED COM0 corresponding the SEG7-SEG0 data register (matrix driver). LED0 dot matrix drive display data register (dot matrix drive)
F741H	LEDC0DATA1 LED1DATA	LED COM0 corresponding the SEG15-SEG8 data register (matrix driver). LED1 dot matrix drive displays data registers (dot matrix drive).
--	--	--
F744H	LEDC1DATA0 LED2DATA	LED COM1 corresponding the SEG7-SEG0 data register (matrix driver). LED2 dot matrix drive displays data registers (dot matrix drive).
F745H	LEDC1DATA1 LED3DATA	THE LED COM1 corresponding the SEG15-SEG8 data register (matrix driver). LED3 dot matrix drive displays data registers (dot matrix drive).
--	--	--
F748H	LEDC2DATA0 LED4DATA	LED COM2 corresponding the SEG7-SEG0 data register (matrix driver). LED4 dot matrix drive displays data registers (dot matrix drive).
F749H	LEDC2DATA1 LED5DATA	LED COM2 corresponding the SEG15-SEG8 data register (matrix driver). LED5 dot matrix drive displays data registers (dot matrix drive).
--	--	--
F74CH	LEDC3DATA0 LED6DATA	LED COM3 corresponding the SEG7-SEG0 data register (matrix driver). LED6 dot matrix drive displays data registers (dot matrix drive).
F74DH	LEDC3DATA1 LED7DATA	LED COM3 corresponding the SEG15-SEG8 data register (matrix driver). LED0 dot matrix drive displays data registers (dot matrix drive).
--	--	--
F750H	LEDC4DATA0 LED0SEL	LED COM4 corresponding the SEG7-SEG0 data register (matrix driver). LED0 dot matrix drive cycle selection register (dot matrix drive).
F751H	LEDC4DATA1 LED1SEL	LED COM4 corresponding the SEG15-SEG8 data register (matrix driver). LED1 dot matrix drive cycle selection register (dot matrix drive).
--	--	--
F754H	LEDC5DATA0 LED2SEL	THE LED COM5 corresponding the SEG7-SEG0 data register (matrix driver). LED2 dot matrix drive cycle selection register (dot matrix drive).
F755H	LEDC5DATA1 LED3SEL	The LED COM5 corresponding the SEG15-SEG8 data register (matrix driver).

address	register	Register description
		LED3 dot matrix drive cycle selection register (dot matrix drive).
--	--	--
F758H	LEDC6DATA0 LED4SEL	LED COM6 corresponding the SEG7-SEG0 data register (matrix driver). LED4 dot matrix drive cycle selection register (dot matrix drive).
F759H	LEDC6DATA1 LED5SEL	THE LED COM6 corresponding the SEG15-SEG8 data register (matrix driver). LED5 dot matrix drive cycle selection register (dot matrix drive).
--	--	--
F75CH	LEDC7DATA0 LED6SEL	LED COM7 corresponding the SEG7-SEG0 data register (matrix driver). LED6 dot matrix drive cycle selection register (dot matrix drive).
F75DH	LEDC7DATA1 LED7SEL	THE LED COM7 corresponding the SEG15-SEG8 data register (matrix driver). LED7 dot matrix drive cycle selection register (dot matrix drive).
F75EH	LEDENL	The LED pin drives enable a low 8-bit register
F75FH	LEDENH	Led pin drive enables high 8-bit registers
F760H	LEDCOMEN	LED COM7~COM0 enable control register
F761H	LEDSEGEN0 SCAN1WH	LED SEG7-SEG0 enable register 0 (matrix drive). LED dot matrix drive first stage configuration register 8 bits high (dot matrix drive)
F762H	LEDSEGEN1 SCAN1WL	LED SEG15-SEG8 enable register 1 (matrix drive). LED dot matrix drive first cycle configuration register 8 bits lower (dot matrix drive)
F763H	SCAN2WH	The LED dot matrix drives the second stage of the cycle configuration register 8 bits high
F764H	SCAN2WL	The LED dot matrix drives the second stage of the cycle configuration register 8 bits high
F765H	LEDCON LEDCON1	LED control register (matrix drive). LED dot matrix drive control register (dot matrix drive)
F766H	LEDCLKL LEDCLKL1	LED clock prescale data register 8 bits low (matrix drive). LED dot matrix clock prescale data register low 8 bits (dot matrix drive).
F767H	LEDCLKH LEDCLKH1	The LED clock prescale data register is 8 bits high (matrix driven). LED dot matrix clock prescale data register low 8 bits (dot matrix drive).
F768H	LEDCOMTIME	LED COM port valid time selection register
F769H	LEDMODE	LED drive mode select register
F76AH	LEDSTATUS	LED dot matrix drives status registers

Note: Led matrix drive and dot matrix drive part of the register address is shared.

3. Reset

Reset Time refers to the time from the time the chip resets to the time when the chip starts executing instructions, and its default design value is about 16ms. This time includes oscillator start time, configuration time. This reset time will exist whether the chip is powered on reset or otherwise caused by a reset. In addition, when the oscillator is selected as an external low-speed crystal oscillation (32.768KHz), the reset time (including the oscillation time) is about 1.5s (external capacitor 10pF~22pF) by default.

The chip can be reset in the following ways:

- ◆ Power-on reset;
- ◆ External reset;
- ◆ Low voltage reset;
- ◆ Watchdog overflow reset;
- ◆ Software reset;
- ◆ CONFIG status protection reset;
- ◆ Power on configuration monitoring reset.

When any of the above resets occur, all system registers will return to their default state, the program will stop running, the program counter PC will be cleared to zero, and the program will run from the reset vector 0000H after the reset is completed.

Any kind of reset situation requires a certain response time, and the system provides a perfect reset process to ensure the smooth progress of the reset operation.

3.1 Power-on Reset

Power-on reset is closely related to LVR operation. The process of powering up the system takes a gradually rising curve and takes some time to reach the normal level. The normal timing of the power-on reset is given below:

- Power-up: the system detects that the supply voltage is rising and waits for it to stabilize;
- System initialization: all system registers are set to initial values;
- The oscillator begins to work: the oscillator begins to provide the system clock;
- Execute the program: The power-up ends and the program starts running.

Stabilization Time defaults to 16ms, but if the configuration selects a 32.768KHz crystal oscillator, the settling time is about 1.5s. The power-on reset timing diagram is shown in the following figure:

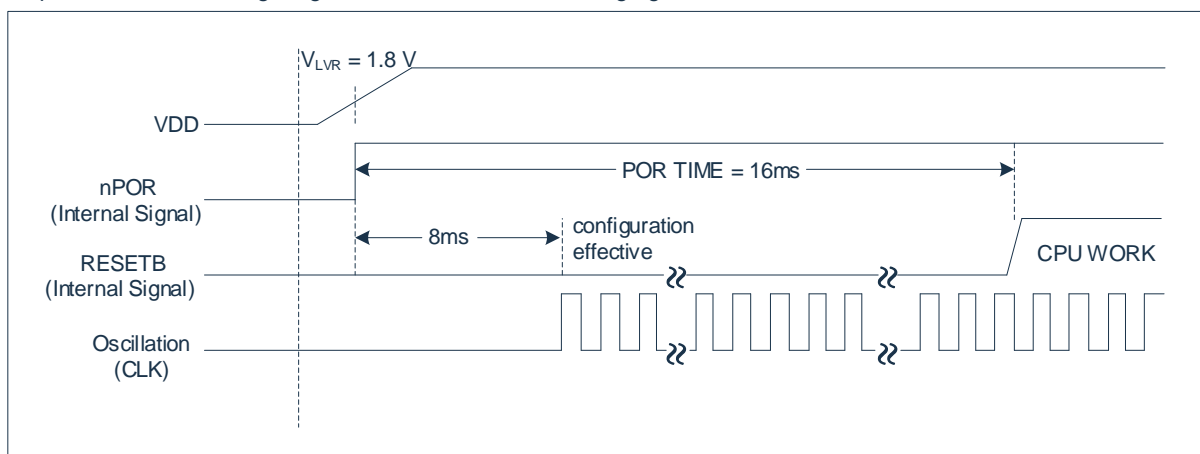

Whether the system is power-on reset can be determined by the PORF (WDCON.6) flag bit. The types of resets that can be placed with a PORF flag of 1 are: power-on reset, LVR reset, external reset, CONFIG protected reset.

0x97	Bit7	Bit6	Bit5	Bit4	Bit3	Bit2	Bit1	Bit0
WDCON	SWRST	PORF	--	--	WDTIF	WDTRF	WDTRE	WDTCLR
R/W	R/W	R/W	R	R	R/W	R/W	R/W	R/W
Reset value	0	1	0	0	0	0	0	0

Bit7	SWRST:	Software reset control bit;
	1:	Perform a system software reset (write 0 clear after reset).
	0:	--
Bit6	PORF:	Power-on reset marker;
	1:	The system resets the system at power-on (write 0 clear, do not need TA to write timing).
	0:	--
Bit5~Bit4	--	Reserved, must be 0.
Bit3	WDTIF:	WDT overflow interrupt flag bit;
	1=	WDT overflow (write 0 cleared);
	0=	WDT does not overflow.
Bit2	WDTRF:	WDT reset marker bit;
	1=	The system is reset by WDT (write 0 cleared);
	0=	The system is not reset by WDT.
Bit1	WDTRE:	WDT reset enable bit;
	1=	Enable WDT reset CPU;
	0=	Disable WDT reset cpu.
Bit0	WDTCLR:	WDT counter clear bit;
	1=	Clear WDT counter (hardware auto-zero);
	0=	Disables the WDT counter (write 0 is invalid).

3.2 External Reset

External reset refers to a reset signal from an external port (NRST) that resets the chip after being input by a Schmitt trigger. If the NRST pin remains low above about 16 μ s (internal LSI clock sampled with 3 rising edges) during operating voltage range and stable oscillation, a reset is requested. After the internal state is initialized and reset state changes to "1", it takes 16ms of settling time for the internal RESETB signal to become "1", and the program starts at vector address 0000H.

The process of reconfiguring the chip during Stabilization Time is the same as the configuration process for power-on reset. The external reset pin NRST and its pull-up resistor enable, configured via CONFIG.

3.3 LVR Low-voltage Reset

A low-voltage reset (LVR) function is integrated inside the chip, and when the system voltage VDD falls below the LVR voltage, the LVR is triggered and the system resets. The voltage point that triggers the reset can be set in CONFIG.

When the LVR module detects that $VDD < V_{LVR}$, it will request reset. In sleep mode (STOP) mode, lvr low-voltage reset disables.

The LVR low-voltage reset timing diagram is shown in the following figure:

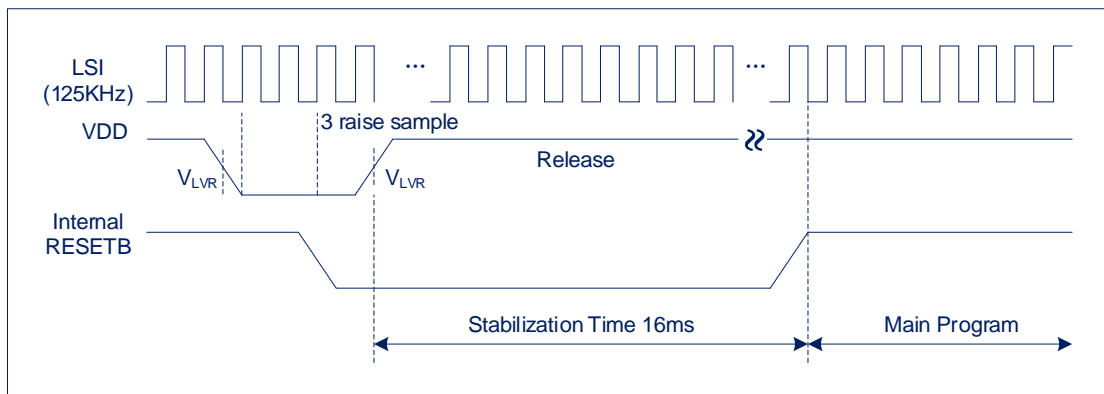

The process of reconfiguring the chip during Stabilization Time is the same as the configuration process for power-on reset.

3.4 Watchdog Reset

Watchdog reset is a protective setting of the system. In normal condition, the watchdog timer is cleared to zero by the program. If an error occurs, the system is in an unknown state, the watchdog timer overflows, and the system resets. After the watchdog is reset, the system reboots into a normal state.

WDT counter is not addressable, the program starts counting after the power-on reset is completed, and it is recommended to clear the WDT counter first when setting the WDT register in order to accurately control the overflow time of the WDT.

The timing of the watchdog reset is as follows:

- 1) Watchdog timer status: the system detects whether the watchdog timer overflows, if overflowing, the system resets;
- 2) Initialization: all system registers are set to the default state;
- 3) Program: The reset is complete and the program starts running from 0000H.

The clock source for the WDT is provided by the system clock, and the timing base period of the WDT counter is T_{sys} . After the WDT overflow resets the CPU with all registers, the program executes immediately after 1 T_{sys} from 0000H. The WDT reset does not reconfigure the power-on reset. The overflow time of the watchdog can be set by the program, and the overflow time can be selected in the CKCON register WDS2-WTS0. The watchdog overflow time is shown in the following table:

WTS[2:0]	Watchdog Interval	Number of clocks	OVT@Fsys=16MHz	OVT@Fsys=48MHz
000	2^{17}	131072	8.192ms	2.731ms
001	2^{18}	262144	16.384ms	5.461ms
010	2^{19}	524288	32.768ms	10.923ms
011	2^{20}	1048576	65.536ms	21.845ms
100	2^{21}	2097152	131.072ms	43.691ms
101	2^{22}	4194304	262.144ms	87.381ms
110	2^{24}	16777216	1.048s	349.525ms
111	2^{26}	67108864	4.194s	1.398s

WDT can also be set to not reset the system, which can produce an interrupt.

3.5 Software Reset

Inside the chip, the program software resets, which relocates the program flow to the reset address 0000H and then runs the program again. The user-writable software reset control bit WDCON[7] (SWRST=1) implements a custom software reset. The software reset does not reconfigure the power-on reset.

3.6 CONFIG Status Protection Reset

CONFIG state protection reset is an enhanced protection mechanism of the system. During power-on reset, there is an internal set of 16-bit CONFIG registers that load the fixed code set in flash (A569H) and do not operate during normal operation. If, in the case of a particular non-program operation, the value of the register changes and is not equal to the original fixed code, and after several clock samples, the register continues to remain in a state that is not fixed code, the system will reset.

This reset mechanism prevents changes in configuration bits under certain conditions, so that the system enters an unpredicted state.

In normal operation, the clock of the sample register value is the internal RC fixed clock Fixed_Clock (8MHz, clock source from HSI) and low power clock (LSI 125KHz), once the value of the register is not a fixed code, force the LSI oscillator and HSI oscillator to be enabled, and the system clock switches to the LSI clock, if after 12 Fixed_Clock sampling or 3 LSI clock sampling, the register remains not in a fixed code state, The system generates a reset.

Under certain conditions, in order to prevent the oscillator from stopping, two clocks are used for sampling.

3.7 Power-on Configuration Monitor Reset

In the power-on configuration process, there is a configuration monitoring circuit inside the chip, if the power-on configuration time is too long, or the power-on configuration into a certain state can not be reconfigured, the internal monitoring circuit from the configuration to start timing, if more than the setting time, the monitoring circuit reset configuration module, so that the configuration module reconfiguration process. In case the system enters an unpredicted state when powered up.

The monitoring circuit operates at LSI (125KHz), the default monitoring time is 65ms, and if the 32.768KHz crystal oscillator is selected, the monitoring time is 2.1s.

4. Clock Structure

There are four types of clock sources for system clocks, and clock source and clock divider can be selected by setting the system configuration register or user register. The system clock sources are as follows:

- ◆ Internal high-speed oscillation HSI (48MHz).
- ◆ External high-speed oscillation HSE (8MHz/16MHz).
- ◆ External low-speed oscillation LSE (32.768KHz).
- ◆ Internal low-speed oscillation LSI (125KHz).

The default clock source of the chip is HSI, and the system clock runs at HSI after the chip reset is complete. If you need to change the system clock source, you can set the system configuration register (with the programming tool and host computer software), or through the user register configuration (follow the procedure to set the relevant register, as detailed below). When using external high-speed and low-speed oscillators as the system clock, the oscillation stop monitoring function is supported, as detailed below.

4.1 System Clock Structure

The system clock block diagram of each peripheral module is shown in the following figure:

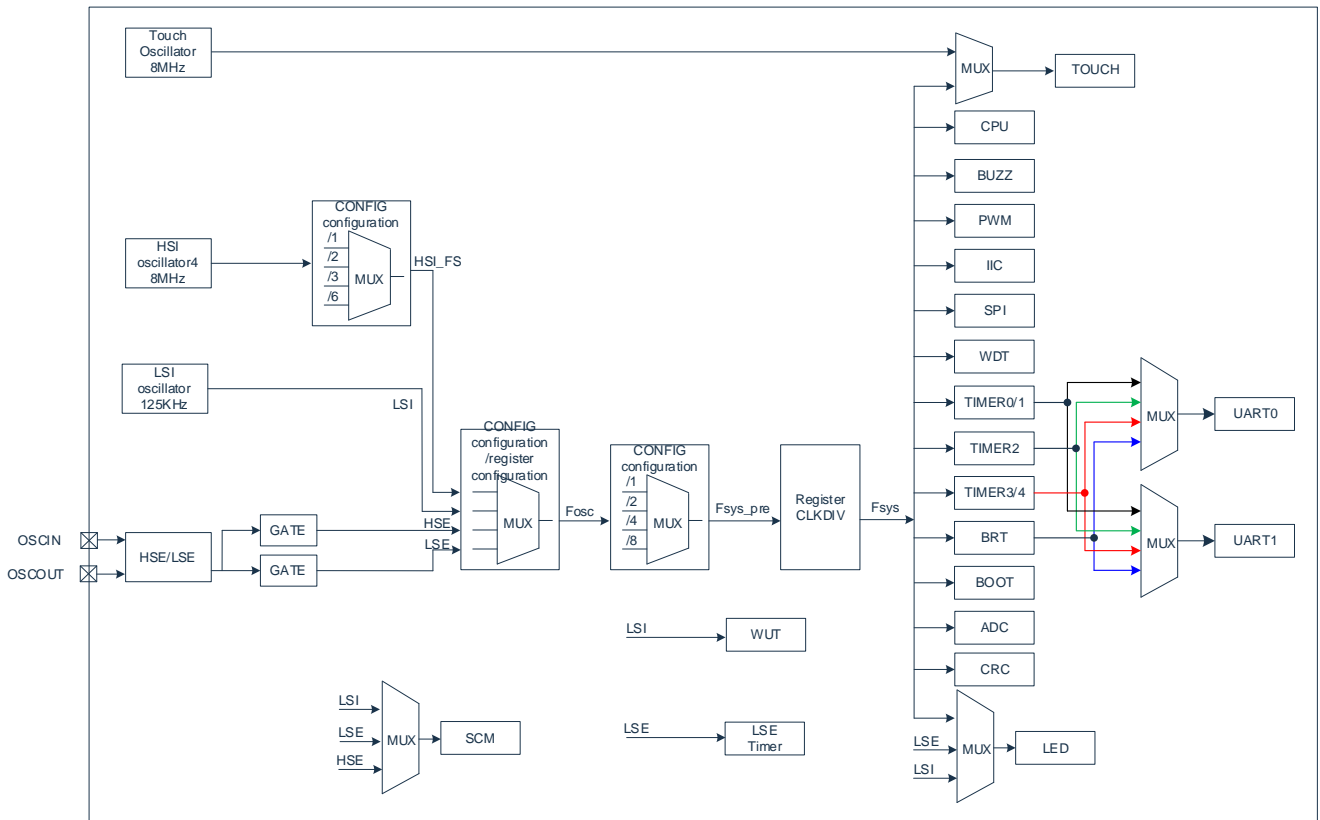

4.2 Related Registers

4.2.1 Oscillator Control Register CLKDIV

0x8F	Bit7	Bit6	Bit5	Bit4	Bit3	Bit2	Bit1	Bit0
CLKDIV	CLKDIV7	CLKDIV6	CLKDIV5	CLKDIV4	CLKDIV3	CLKDIV2	CLKDIV1	CLKDIV0
R/W	R/W	R/W	R/W	R/W	R/W	R/W	R/W	R/W
Reset value	0	0	0	0	0	0	0	0

Bit7~Bit0 CLKDIV<7:0>: System clock Fsys divider;
 00H= Fsys=Fsys_pre;
 Other = Fsys=Fsys_pre/ (2*CLKDIV) (2,4... 510 division).

Modify the sequence of instructions required by CLKDIV (no other instructions can be inserted in the middle):

MOV	TA,#0AAH
MOV	TA,#055H
MOV	CLKDIV,#02H

4.2.2 System Clock Switching Register SCKSEL

0xD6	Bit7	Bit6	Bit5	Bit4	Bit3	Bit2	Bit1	Bit0
SCKSEL	--	--	--	SALT	WRITE	CKSEL2	CKSEL1	CKSEL0
R/W	R	R/W	R/W	R/W	R/W	R/W	R/W	R/W
Reset value	0	0	0	0	0	0	0	0

Bit7 -- Forbidden Access.
 Bit6~Bit5 -- Reserved, must be 0.
 Bit4 SALT: System clock configuration selection;
 1= Based on the clock source configured > CKSEL < 2:0;
 0= The clock source configured by CONFIG is the standard (power-up default selection).
 Bit3 WRITE: Write enable, generate a pulse, perform clock switching;
 1= Switch clocks (you need to wait for the switching target clock source to stabilize bit set to 1 before you can write 1);
 0= Do not switch clocks.
 Bit2~Bit0 CKSEL<2:0>: System clock source select bit;
 111= LSI;
 110= LSE;
 101= HSE;
 100= HSI;
 Other = Invalid value, access prohibited.

After the clock source is switched, the system will successfully switch within several system clock cycles, and it is recommended that the program execute 6 NOPs before executing other instructions.

Modify the sequence of instructions required by SCKSEL (no other instructions can be inserted in between):

MOV	TA,#0AAH
MOV	TA,#055H
MOV	SCKSEL,#05H

4.2.3 System Clock Status Register SCKSTAU

0xD7	Bit7	Bit6	Bit5	Bit4	Bit3	Bit2	Bit1	Bit0
SCKSTAU	LSI_F	LSE_F	HSE_F	HSI_F	--	--	--	--
R/W	R	R	R	R	RW	R/W	R/W	R/W
Reset value	0	0	0	0	0	0	0	0

- Bit7 LSI_F: Low-speed internal steady-state bit;
 1= Stability;
 0= Not stable.
- Bit6 LSE_F: Steady state bit of low-speed external crystal;
 1= Stability;
 0= Not stable.
- Bit5 HSE_F: High-speed external crystal stabilized state bit;
 1= Stability;
 0= Not stable.
- Bit4 HSI_F: High-speed internal clock steady-state bit;
 1= Stable.
 0= Not stable.
- Bit3~0 -- Forbidden Access.

4.2.4 System Clock Monitor Register SCM

F697H	Bit7	Bit6	Bit5	Bit4	Bit3	Bit2	Bit1	Bit0
XT_SCM	SCMEN	SCMIE	--	--	--	--	SCMIF	SCMSTA
R/W	R/W	R/W	R/W	R/W	R/W	R/W	R/W	R
Reset value	0	0	0	0	0	0	0	0

Bit7 SCMEN: Oscillation stop detection module enable;

1= Enable;

0= Disable.

Bit6 SCMIE: Stop detection interrupt enable bit (this interrupt and LSE timer interrupt share a single interrupt entry);

1= Enable;

0= Disable.

Bit5~Bit2 -- Reserved, must be 0.

Bit1 SCMIF: Stop interrupt flag bit;

1= Indicates oscillation stopping;

0= The software clears 0, and after clearing 0, it will automatically switch to the HSE/LSE frequency (only the software can clear 0).

Bit0 SCMSTA: Stop status bit, read-only;

1= Indicates oscillation stopping;

0= Shutdown recovery.

Note:

- 1) Both SCMIF and SCMSTA can reflect the state of the HSE/LSE system clock. The biggest difference between the two is that when the HSE/LSE is stopped, the SCMSTA will remain at a high level until the HSE/LSE is restored; SCMIF can also reflect HSE/LSE shutdown, but it can produce an interrupt (interrupt enable is required), or it can clear the SCMIF through the register, and the frequency will switch back to HSE/LSE after clearing (if it is still in a stalled state at this time, the interrupt will be triggered again).
- 2) After the oscillation is stopped, the main frequency will be cut from HSE/LSE to HSI, if HSE/LSE is restored, SCMSTA will automatically clear zero, and the main frequency will also be automatically switched back to HSE/LSE by HSI.

4.4 System Clock Monitoring

System Clock Monitoring (SCM) is a monitoring and protection circuit designed to prevent the system from not working due to crystal oscillation suspension. When using HSE/LSE as the system clock, once the HSE/LSE clock stops, the system will force the HSI clock source to start, and the system will run at 8MHz after the HSI is stabilized, and then if the HSE/LSE clock is restored and stable, the system clock will automatically switch back from the HSI back to HSE/LSE.

The SCM module monitors the system clock HSE/LSE every 4ms, and the duty cycle of the T_{SCM} is 1:1. When T_{SCM} is high, SCM performs oscillation stop monitoring of HSE/LSE, T_{SCM} processes the monitoring results during low level, and if HSE/LSE stop is detected, the system clock is switched to HSI, and the stop interrupt flag SCMIF is set to 1. If SCMIF is cleared, the system clock will automatically switch back to HSE/LSE even if the HSE/LSE has stopped.

The system clock monitoring block diagram is shown in the following figure:

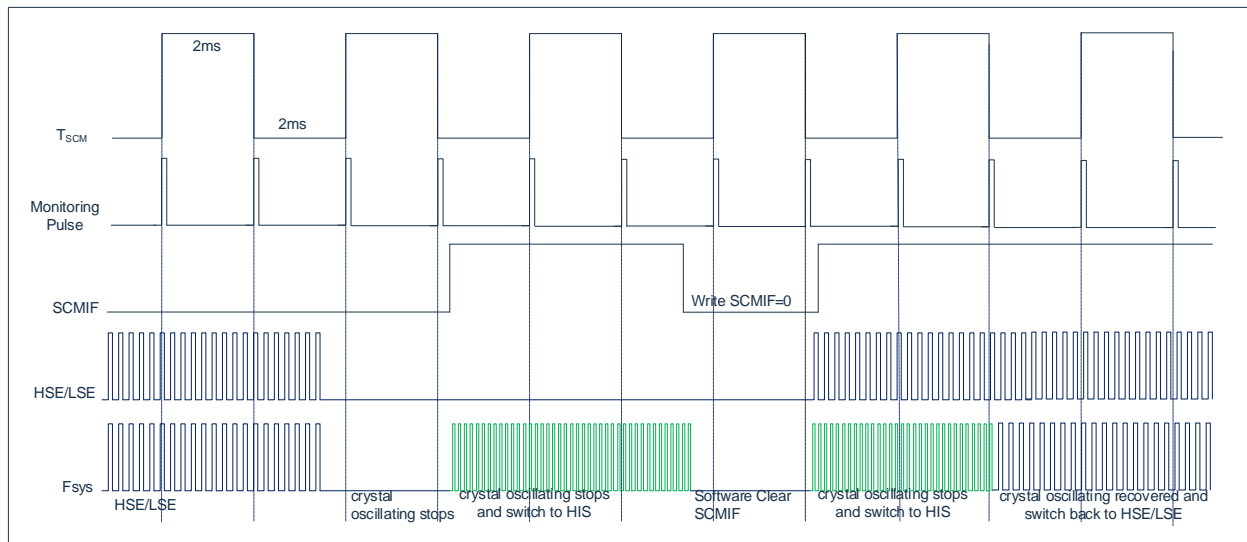

5. Power Management

Low-power modes fall into 2 categories:

- ◆ IDLE: Idle mode
- ◆ STOP: Sleep mode

When users use C language for program development, it is strongly recommended to use IDLE and STOP macros to control the system mode, and do not directly set THE IDLE and STOP bits. The macros are as follows:

Enter idle mode: IDLE();

Enter sleep mode: STOP();

5.1 Power Management Register PCON

0x87	Bit7	Bit6	Bit5	Bit4	Bit3	Bit2	Bit1	Bit0
PCON	SMOD0	SMOD1	--	--	--	THEIR	STOP	IDLE
R/W	R/W	R/W	R/W	R/W	R/W	R/W	R/W	R/W
Reset value	0	0	0	0	0	0	0	0

Bit7	SMOD0: UART0 baud rate multiplier; 0= UART0 baud rate is normal; 1= The UART0 baud rate doubles.
Bit6	SMOD1: UART1 baud rate multiplier; 0= UART1 baud rate is normal; 1= The UART1 baud rate is doubled.
Bit5~Bit3	-- Reserved, all must be 0.
Bit2	THEIR: STOP status function wake-up enable bit; (The system can be restarted by a power-down reset or an enabled external reset regardless of the SWE value) 0= Disables functional wake-up; 1= Enables function wake-up (wake-up by external interrupts and timed wake-ups).
Bit1	STOP: Sleep state control bit; 0= Not in hibernation; 1= Enters a hibernate state (exits STOP mode to automatically clear zero).
Bit0	IDLE: Idle state control bit; 0= Not in the idle state; 1= Enter the idle state (exit IDLE mode to clear automatically).

5.2 Power Supply Monitor Register LVDCON

The MCU comes with a power supply detection function. If the LVD module enable (LVDEN=1) is set and the voltage monitoring point LVDSEL is set, when the power supply voltage drops below the LVD setpoint, an interrupt will be generated to alert the user.

If the LVD module is enabled before hibernation, the hardware will not close the module circuit after entering hibernation, and a software shutdown is required (LVDEN=0).

0xF690	Bit7	Bit6	Bit5	Bit4	Bit3	Bit2	Bit1	Bit0
LVDCON	LVDSEL3	LVDSEL2	LVDSEL1	LVDSEL0	LVDEN	--	LVDINTE	LVDINTF
R/W	R/W	R/W	R/W	R/W	R/W	R/W	R/W	R/W
Reset value	0	0	0	0	0	0	0	0

Bit7~Bit4 LVDSEL<3:0>: LVD voltage monitoring points;

0000=	2.00V;	1000=	2.00V;
0001=	2.20V;	1001=	2.00V;
0010=	2.00V;	1010=	3.70V;
0011=	2.40V;	1011=	2.00V;
0100=	2.00V;	1100=	4.00V;
0101=	2.70V;	1101=	4.30V;
0110=	2.00V;	1110=	2.00V;
0111=	3.00V;	1111=	2.00V.

Bit3 LVDEN: LVD enable;

0= Prohibited;

1= Enable.

Bit2 -- Reserved, must be 0.

Bit1 LVDINTE: LVD interrupt enable bit;

0= LVD Interrupt disabled;

1= LVD interrupt enablement.

Bit0 LVDINTF: LVD interrupt flag bit;

0= The supply voltage is higher than the monitoring voltage;

1= The supply voltage is lower than the monitor voltage (software zero).

5.3 IDLE Idle Mode

In this mode, only the CPU clock source is turned off. As a result, peripheral functions such as timers, PWM, I2C and clock generators (HSI/crystal drivers) are still functioning in this state.

After the system enters idle mode, it can be woken up by any interrupt, enter the interrupt handler after waking, and continue to perform the post-hibernation operation after the interrupt returns.

If idle mode is entered in the interrupt service program, the system can only be woken up by a higher priority interrupt.

5.4 STOP Sleep Mode

In this mode, all circuits except the LVD module and LSE module are shut down (the LVD/LSE module must be closed by software), the system is in a low-power mode, and the digital circuits are not working.

5.4.1 Sleep Wakes up

After entering the sleep mode, you can turn on the sleep wake function (SWE=1 need to be set) to wake up the sleep mode. There are several ways to wake up sleep mode:

1) INT0/1 interrupt

With INT0/1 interrupt wake-up sleep mode, the global interrupt enable must be turned on with the INT0/1 interrupt enable before entering hibernation to wake up the system. INT0, INT1 interrupt-related registers include IE, IP, TCON, IO multiplexed mapping registers, INT0/1 interrupt wake-up can only drop along the interrupt wake-up sleep.

2) External (GPIO) interrupt

With an external GPIO interrupt wake-up, the global interrupt enable and the port interrupt enable must be turned on before entering hibernation to wake up the system. External GPIO interrupt wake-up can be selected for rising-edge, falling-edge, dual-edge interrupt wake-up sleep, and the interrupt wake-up edge is set by the external interrupt control register PxnEICFG.

3) WUT timed wake-up

To wake up by WUT, the timed wake function must be turned on before entering hibernation, and the hibernation state must be set to the time of wake-up. The clock source of the timed wake-up circuit is provided by the LSI (Low Power Oscillator), and the timed wake-up function is turned on automatically when the timed wake-up function is turned on in the sleep state.

4) LSE timed wake-up

To wake up by LSE timing, the LSE module enable, count enable, and timed wake function must be turned on before entering hibernation, and the hibernation state must be set to wake up time.

5.4.2 Wake-up Wait State

Whether it is an INT0/1 interrupt, an external GPIO interrupt, or a WUT timed wake-up, LSE timed wake-up sleep mode, after the interrupt is generated or the configured time arrives, it takes a period of time to wake up the system and execute the next instruction of the program. After the interrupt is generated or the configured time expires, the system oscillator starts, but the oscillation frequency is not stable, the CPU is not working, the PC still stops in hibernation, and the system needs to wait for a period of time to provide the clock to the CPU. The wait time to wake up the CPU is set in the flashing CONFIG, and the wait time can be set to 50us~1s. After the wake-up wait time, the MCU believes that the system clock has stabilized, and then provides the clock to the CPU, and the program continues to execute.

If both the internal wake-up timer and the external interrupt wake-up function are turned on, either wake-up mode can wake up the CPU after the system enters sleep mode. If the internal timer wakes up the oscillator first and then has an external interrupt input, after the wake-up wait time has elapsed, the program executes the interrupt handler and then continues with the instructions after the hibernation operation.

5.4.3 Sleep Wake-up Time

The total wake-up time of the system with an external interrupt wake-up system is:

Power Manager Settling Time (200us) + Wake-up Wait Time

The total wake-up time of the system with timed wake-up is:

Power Manager Settling Time (200us) + Timing of wake-up timer + Wake-up wait time

(The above given time condition is $F_{sys} > 1\text{MHz}$)

5.4.4 Reset Operation Under Sleep

In sleep mode, the system can also be restarted by power-down reset or external reset, independent of the value of SWE, even if SWE=0 can also restart the system by the above reset operation.

Power-down reset: No other conditions are required, VDD is reduced to 0V and then powered back on to the working voltage and enters the power-on reset state.

External reset: you need to open the external reset function, the relevant port is configured as a dedicated reset port, the reset port remains low >1us when sleeping, the system generates a reset, release the reset port, then the system restarts.

5.4.5 Sleep Power Consumption in Debug Mode

The sleep state in debug mode does not reflect the actual chip sleep state.

In debug mode, after the system enters a sleep state, the associated power management circuit, the oscillator does not turn off, but continues to turn on. Wake-up operations can also be performed in debug mode in the same way as normal mode.

Therefore, in this state, the sleep current obtained by the test is not the real sleep power consumption. It is recommended to turn off debug mode after the development of the sleep wake function is completed in debug mode, and then restart the system, at which time the measured current is the actual sleep power consumption.

5.4.6 Example of a Sleep Mode Application

Before the system enters the sleep mode, if the user needs to obtain a small sleep current, please confirm the state of all I/O, if there is a suspended I/O port in the user solution, set all the suspended ports as output ports, to ensure that each input port has a fixed state, to avoid I/O as the input state, the port line level is in a static state and increase the sleep current; Power down ADC modules, LSE modules, LVD modules, and other peripherals to reduce sleep current.

Example: Handler that goes into hibernation when using a timed wake-up (assembler)

```

SLEEP_MODE:
    MOV                WUTCRL,#31h
    MOV                WUTCRLH,#80h
    MOV                P0TRIS,#0FFh
    MOV                P0,#0FFh
    MOV                P1TRIS,#0FFh
    MOV                P1,#0FFh
    MOV                P2TRIS,#0FFh
    MOV                P2,#0FFh
    Instructions to turn off other
    functions
    MOV                PCON,#06H        ; Perform a hibernation operation that can be
    woken up,
    NOP
    NOP
    NOP
    NOP
    NOP
    NOP
    NOP                ; The instruction to perform the sleep operation must be followed by
    6 NOP instructions
    Other action instructions after
    wake-up
  
```

6. Interrupt

6.1 Interrupt Overview

The chip has 22 interrupt sources and interrupt vectors:

Interrupt source	Interrupt description	Interrupt vector	Sibling priority sequence
INT0	External interrupt 0	0-0x0003	1
Timer0	Timer 0 interrupt	1-0x000B	2
INT1	External interrupt 1	2-0x0013	3
Timer1	Timer 1 interrupt	3-0x001B	4
UART0	T10 or RI0	4-0x0023	5
Timer2	Timer 2 interrupt	5-0x002B	6
UART1	T11 or RI1	6-0x0033	7
P0EXTIF<7:0>	P0 port external interrupt	7-0x003B	8
P1EXTIF<7:0>	P1 port external interrupt	8-0x0043	9
P2EXTIF<7:0>	P2 port external interrupt	9-0x004B	10
--	--	10-0x0053	11
--	--	11-0x005B	12
P5EXTIF<7:0>	P5 port external interrupt	12-0x0063	13
--	--	13-0x006B	14
--	--	14-0x0073	15
Timer3	Timer 3 interrupt	15-0x007B	16
Timer4	Timer 4 interrupt	16-0x0083	17
LED	LED dot matrix scanning is interrupted	17-0x008B	18
PWM	PWM interrupt	18-0x0093	19
ADC	ADC interrupt	19-0x009B	20
WDT	WDT interrupt	20-0x00A3	21
I ² C	I2C interrupt	21-0x00AB	22
SPI	SPI interrupt	22-0x00B3	23
--	--	23-0x00BB	24
--	--	24-0x00C3	25
LSE_Timer/SCM	LSE timer interrupt/SCM	25-0x00CB	26
LVD	LVD power-down interrupt	26-0x00D3	27
TOUCH	Touch Interrupt	27-0x00DB	28

LSE timers LSE_Timer interrupts and oscillation stop monitoring SCM interrupts share a single interrupt vector entry, but they have independent interrupt enable bits.

The chip specifies two interrupt priorities, allowing for two levels of interrupt nesting. When an interrupt has already responded, if a high-level interrupt is requested, the latter can interrupt the former, implementing interrupt nesting.

6.2 External Interrupts

6.2.1 INT0/INT1 Interrupt

The chip supports the 8051 native INT0, INT1 external interrupt, INT0/INT1 can choose to falling edge or low level trigger interrupt, the relevant control register is TCON. INT0 and INT1 occupy two interrupt vectors.

6.2.2 GPIO Interrupt

Each GPIO pin of the chip supports an external interrupt and can support falling/rising/dual edge interrupts, with the edge trigger type configured through the P_xNEICFG registers. For example, configure the P13 port to falling edge interrupt:

```
P13CFG=0x00; //Set P13 to GPIO
P1TRIS&=0xF7; Set P13 as the input port
P13EICFG=0x02; //Set P13 as a falling edge trigger interrupt
```

GPIO interrupts occupy a total of 4 interrupt vectors:

Port P0 occupies an interrupt vector 0x003B;

Port P1 occupies an interrupt vector 0x0043;

Port P2 occupies an interrupt vector 0x004B;

Port P5 occupies an interrupt vector 0x0063.

When an interrupt occurs, the interrupt service program can first determine which port triggered the interrupt, and then process it accordingly.

6.3 Interrupt With Sleep Wake-up

After the system enters sleep mode (STOP wakeable mode), each external interrupt can be set to wake up the system.

INT0/INT1 interrupt wake-up system needs to turn on the corresponding interrupt enable and global interrupt enable, and the wake-up mode is the falling edge wake-up (INT0/INT1 wake-up mode and interrupt trigger mode select bit IT0/IT1 are independent).

GPIO interrupt wake-up system, it is recommended to set the corresponding port interrupt trigger edge mode before entering sleep mode (GPIO wake-up mode is the same as interrupt trigger edge mode, you can choose rising edge/ falling edge /double edge wake-up), and turn on the corresponding interrupt enable and global interrupt enable.

After the system is woken up by an external interrupt, it first enters the interrupt service program to handle the interrupt wake task, and after exiting the interrupt service program, the system continues to perform instructions after the hibernation operation.

6.4 Interrupt Register

6.4.1 Interrupt Mask Registers

6.4.1.1 Interrupt Mask Register IE

Interrupt mask register IE is a read-write register that can be operated bitwise. When an interrupt condition arises, the interrupt flag bit will be set to 1 regardless of the state of the corresponding interrupt enable bit or the global enable bit EA. The user software should ensure that the corresponding interrupt flag bits are cleared to zero before enabling an interrupt.

0xA8	Bit7	Bit6	Bit5	Bit4	Bit3	Bit2	Bit1	Bit0
IE	SHE	ES1	ET2	ES0	ET1	EX1	ET0	EX0
R/W	R/W	R/W	R/W	R/W	R/W	R/W	R/W	R/W
Reset value	0	0	0	0	0	0	0	0

Bit7	SHE: Global interrupt enable bits; 1= Enable all unblocked interrupts; 0= Disable all interrupts.
Bit6	ES1: UART1 interrupt enable bit; 1= EnableS UART1 interrupt; 0= Disable UART1 Interrupt.
Bit5	ET2: TIMER2 Global interrupt Enable bits; 1= Enable all interrupts of TIMER2; 0= All interrupts of TIMER2 are prohibited.
Bit4	ES0: UART0 interrupt enable bit; 1= Enable UART0 interrupts; 0= Disable UART0 Interrupt.
Bit3	ET1: TIMER1 interrupt enable bit; 1= Enable TIMER1 interrupts; 0= Prohibited TIMER1 interrupt.
Bit2	EX1: External interrupt 1 interrupt Enables bits; 1= Enable external interrupt 1 interrupt; 0= Disable external interrupt 1 interrupt.
Bit1	ET0: TIMER0 interrupt enable bits; 1= Enable TIMER0 interrupt; 0= Disable TIMER 0 Interrupt.
Bit0	EX0: External interrupt 0 interrupt enable bit; 1= Enable external interrupt 0 interrupts; 0= Disable external interrupt 0 interrupt.

6.4.1.2 Interrupt Mask Register EIE2

0xAA	Bit7	Bit6	Bit5	Bit4	Bit3	Bit2	Bit1	Bit0
EIE2	SPIIE	I2CIE	WDTIE	ADCIE	PWMIE	--	ET4	ET3
R/W	R/W	R/W	R/W	R/W	R/W	R/W	R/W	R/W
Reset value	0	0	0	0	0	0	0	0

- Bit7 SPIIE: SPI interrupt enable bit;
 1= Enable SPI interrupts;
 0= Prohibited SPI Interrupt.
- Bit6 I2CIE: I2C interrupt enable bit;
 1= Enable I2C interrupts;
 0= Disable I²C interrupt.
- Bit5 WDTIE: WDT interrupt enable bit;
 1= Enable WDT overflow interrupts;
 0= Disable WDT overflow interrupts.
- Bit4 ADCIE: ADC interrupt enable bit;
 1= Enable ADC interrupts;
 0= Prohibited ADC interrupts.
- Bit3 PWMIE: PWM global interrupt enable bit;
 1= Enable all PWM interrupts;
 0= Disable all PWM interrupts.
- Bit2 -- Reserved, must be 0.
- Bit1 ET4: Timer4 interrupt enable bit;
 1= Enable Timer4 interrupts;
 0= Disable Timer4 Interrupt.
- Bit0 ET3: Timer3 interrupt enable bit;
 1= Enable Timer3 interrupts;
 0= Disable Timer3 interrupt.

6.4.1.3 Timer2 Interrupt Mask Register T2IE

0xCF	Bit7	Bit6	Bit5	Bit4	Bit3	Bit2	Bit1	Bit0
T2IE	T2OVIE	T2EXIE	--	--	T2C3IE	T2C2IE	T2C1IE	T2C0IE
R/W	R/W	R/W	R/W	R/W	R/W	R/W	R/W	R/W
Reset value	0	0	0	0	0	0	0	0

- Bit7 T2OVIE: Timer2 overflow interrupt enable bits;
 1= Interrupts are Enabled;
 0= Disable Interrupt.
- Bit6 T2EXIE: Timer2 external loading interrupt Enables bits;
 1= Interrupts are Enabled;
 0= Disable Interrupt.
- Bit5~Bit4 -- Reserved, must be 0.
- Bit3 T2C3IE: Timer2 compares channel 3 interrupt Enable bits;
 1= Interrupts are Enabled;
 0= Disable Interrupt.
- Bit2 T2C2IE: Timer2 compares channel 2 interrupt enable bits;
 1= Interrupts are Enabled;
 0= Disable Interrupt.

- Bit1 T2C1IE: Timer2 compares channel 1 interrupt enable bits;
 1= Interrupts are Enabled;
 0= Disable Interrupt.
- Bit0 T2C0IE: Timer2 compares channel 0 interrupt Enabled bits;
 1= Interrupts are Enabled;
 0= Disable Interrupt.

If you want to enable the interrupt of Timer2, you also need to turn on the global interrupt enable bit ET2=1 of Timer2 (IE.5=1)

6.4.1.4 P0 Interrupt Control Register P0EXTIE

0xAC	Bit7	Bit6	Bit5	Bit4	Bit3	Bit2	Bit1	Bit0
P0EXTIE	P07IE	P06IE	P05IE	P04IE	P03IE	P02IE	P01IE	P00IE
R/W	R/W	R/W	R/W	R/W	R/W	R/W	R/W	R/W
Reset value	0	0	0	0	0	0	0	0

- Bit7~Bit0 P0iIE: P0i port interrupt Enabled bits (i=0-7);
 1= Interrupts are Enabled;
 0= Disable Interrupt.

6.4.1.5 Port P1 Interrupt Control Register P1EXTIE

0xAD	Bit7	Bit6	Bit5	Bit4	Bit3	Bit2	Bit1	Bit0
P1EXTIE	P17IE	P16IE	P15IE	P14IE	P13IE	P12IE	P11IE	P10IE
R/W	R/W	R/W	R/W	R/W	R/W	R/W	R/W	R/W
Reset value	0	0	0	0	0	0	0	0

- Bit7~Bit0 P1iIE: P1i interrupt enable bits (i=0-7);
 1= Interrupts are Enabled;
 0= Disable Interrupt.

6.4.1.6 P2 Interrupt Control Register P2EXTIE

0xAE	Bit7	Bit6	Bit5	Bit4	Bit3	Bit2	Bit1	Bit0
P2EXTIE	--	--	--	--	P23IE	P22IE	P21IE	P20IE
R/W	R/W	R/W	R/W	R/W	R/W	R/W	R/W	R/W
Reset value	0	0	0	0	0	0	0	0

- Bit7~Bit4 -- Reserved, must be 0.
- Bit3~Bit0 P2iIE: P2i port interrupt Enabled bits (i=0-3);
 1= Interrupts are Enabled;
 0= Disable Interrupt.

6.4.1.7 P5 Interrupt Control Register P5EXTIE

0x9C	Bit7	Bit6	Bit5	Bit4	Bit3	Bit2	Bit1	Bit0
P5EXTIE	--	--	P55IE	P54IE	P53IE	P52IE	P51IE	P50IE
R/W	R/W	R/W	R/W	R/W	R/W	R/W	R/W	R/W
Reset value	0	0	0	0	0	0	0	0

Bit7~Bit6 -- Reserved, must be 0.
 Bit5~Bit0 P5iIE: P5i port interrupt enable bits (i=0-5);
 1= Interrupts are Enabled;
 0= Disable Interrupt.

6.4.2 Interrupt Priority Controls the Register

6.4.2.1 Interrupt Priority Control Register IP

Interrupt priority control register IP is a read-write register that can be operated bitwise.

0xB8	Bit7	Bit6	Bit5	Bit4	Bit3	Bit2	Bit1	Bit0
IP	--	PS1	PT2	PS0	PT1	PX1	PT0	PX0
R/W	R/W	R/W	R/W	R/W	R/W	R/W	R/W	R/W
Reset value	0	0	0	0	0	0	0	0

- Bit7 -- Reserved, must be 0.
- Bit6 PS1: UART1 interrupt priority control bit;
 1= Set to High-level Interrupt;
 0= Set to low-level interrupt.
- Bit5 PT2: TIMER2 interrupt priority control bit;
 1= Set to High-level Interrupt;
 0= Set to low-level interrupt.
- Bit4 PS0: UART0 interrupt priority control bit;
 1= Set to High-level Interrupt;
 0= Set to low-level interrupt.
- Bit3 PT1: TIMER1 interrupt priority control bit;
 1= Set to High-level Interrupt;
 0= Set to low-level interrupt.
- Bit2 PX1: External interrupt 1 interrupt priority control bit;
 1= Set to High-level Interrupt;
 0= Set to low-level interrupt.
- Bit1 PT0: TIMER0 interrupt priority control bit;
 1= Set to High-level Interrupt;
 0= Set to low-level interrupt.
- Bit0 PX0: External interrupt 0 interrupt priority control bit;
 1= Set to High-level Interrupt;
 0= Set to low-level interrupt.

6.4.2.2 Interrupt Priority Control Register EIP1

0xB9	Bit7	Bit6	Bit5	Bit4	Bit3	Bit2	Bit1	Bit0
EIP1	--	--	PP5	--	--	PP2	PP1	PP0
R/W	R/W	R/W	R/W	R/W	R/W	R/W	R/W	R/W
Reset value	0	0	0	0	0	0	0	0

- Bit7 -- Reserved, must be 0.
- Bit6 -- Reserved, must be 0.
- Bit5 PP5: P5 port interrupt priority control bit;
 1= Set to High-level Interrupt;
 0= Set to low-level interrupt.
- Bit4~Bit3 -- Reserved, must be 0.
- Bit2 PP2: P2 port interrupt priority control bit;
 1= Set to High-level Interrupt;
 0= Set to low-level interrupt.
- Bit1 PP1: P1 port interrupt priority control bit;

1= Set to High-level Interrupt;
 0= Set to low-level interrupt.
 Bit0 PP0: P0 port interrupt priority control bit;
 1= Set to High-level Interrupt;
 0= Set to low-level interrupt.

6.4.2.3 Interrupt Priority Control Register EIP2

0xBA	Bit7	Bit6	Bit5	Bit4	Bit3	Bit2	Bit1	Bit0
EIP2	PSPI	PI2C	PWDT	PADC	PPWM	PLED	PT4	PT3
R/W	R/W	R/W	R/W	R/W	R/W	R/W	R/W	R/W
Reset value	0	0	0	0	0	0	0	0

Bit7 PSPI: SPI interrupt priority control bit;
 1= Set to High-level Interrupt;
 0= Set to low-level interrupt.
 Bit6 PI2C: I2C interrupt priority control bit;
 1= Set to High-level Interrupt;
 0= Set to low-level interrupt.
 Bit5 PWDT: WDT interrupt priority control bit;
 1= Set to High-level Interrupt;
 0= Set to low-level interrupt.
 Bit4 PADC: ADC interrupt priority control bit;
 1= Set to High-level Interrupt;
 0= Set to low-level interrupt.
 Bit3 PPWM: PWM interrupt priority control bit
 1= Set to High-level Interrupt;
 0= Set to low-level interrupt.
 Bit2 PLED: LED dot matrix scan interrupt priority control bit
 1= Set to High-level Interrupt;
 0= Set to low-level interrupt.
 Bit1 PT4: TIMER4 interrupt priority control bit;
 1= Set to High-level Interrupt;
 0= Set to low-level interrupt.
 Bit0 PT3: TIMER3 interrupt priority control bit;
 1= Set to High-level Interrupt;
 0= Set to low-level interrupt.

6.4.2.4 Interrupt Priority Control Register EIP3

0xBB	Bit7	Bit6	Bit5	Bit4	Bit3	Bit2	Bit1	Bit0
EIP3	--	--	--	--	PLVD	PLSE	--	--
R/W	R/W	R/W	R/W	R/W	R/W	R/W	R/W	R/W
Reset value	0	0	0	0	0	0	0	0

- Bit7~Bit5 -- Reserved, must be 0.
- Bit4 PTOUCH TOUCH interrupt priority control bit;
 1= Set to High-level Interrupt;
 0= Set to low-level interrupt.
- Bit3 PLVD: LVD interrupt priority control bit;
 1= Set to High-level Interrupt;
 0= Set to low-level interrupt.
- Bit2 PLSE: LSE interrupt priority control bit;
 1= Set to High-level Interrupt;
 0= Set to low-level interrupt.
- Bit1~Bit0 -- Reserved, must be 0.

6.4.3 Interrupt Flag Bit Register

6.4.3.1 Timer0/1, INT0/1 Interrupt Flag Bit Register TCON

0x88	Bit7	Bit6	Bit5	Bit4	Bit3	Bit2	Bit1	Bit0
TCON	TF1	TR1	TF0	TR0	IE1	IT1	IE0	IT0
R/W	R/W	R/W	R/W	R/W	R/W	R/W	R/W	R/W
Reset value	0	0	0	0	0	0	0	0

- Bit7 TF1: Timer1 counter overflow interrupt flag bit;
 1= Timer1 counter overflow, when entering the interrupt service program, the hardware is automatically cleared, and the software can also be cleared;
 0= The Timer1 counter has no overflow.
- Bit6 TR1: Timer1 operational control bit;
 1= Timer1 starts;
 0= Timer1 closes.
- Bit5 TF0: Timer0 counter overflow interrupt flag bit;
 1= Timer0 counter overflow, when entering the interrupt service program, the hardware is automatically cleared, and the software can also be cleared;
 0= The Timer0 counter has no overflow.
- Bit4 TR0: Timer0 operational control bit;
 1= Timer0 starts.
 0= Timer0 closes.
- Bit3 IE1: External interrupt 1 flag;
 1= External interrupt 1 generates an interrupt, the hardware is automatically cleared when entering the interrupt service program, and the software can also be cleared;
 0= External interrupt 1 did not produce an interrupt.
- Bit2 IT1: External interrupt 1 trigger mode control bit;
 1= Falling edge trigger;
 0= Low level triggering.
- Bit1 IE0: External interrupt 0 flag;
 1= External interrupt 0 generates an interrupt, the hardware is automatically cleared when entering the interrupt service program, and the software can also be cleared;
 0= External interrupt 0 did not produce an interrupt.
- Bit0 IT0: External interrupt 0 trigger mode control bit;
 1= Falling edge trigger;
 0= Low level triggering.

6.4.3.2 Timer2 Interrupt Flag Bit Register T2IF

0xC9	Bit7	Bit6	Bit5	Bit4	Bit3	Bit2	Bit1	Bit0
T2IF	TF2	T2EXIF	--	--	T2C3IF	T2C2IF	T2C1IF	T2C0IF
R/W	R/W	R/W	R/W	R/W	R/W	R/W	R/W	R/W
Reset value	0	0	0	0	0	0	0	0

- Bit7 TF2: Timer2 counter overflow interrupt flag bit;
 1= Timer2 counter overflow, software zeroing is required;
 0= The Timer2 counter has no overflow.
- Bit6 T2EXIF: Timer2 externally loaded flag bits;
 1= The T2EX port of Timer2 generates a falling edge, which requires software clearance;
 0= --

Bit5~Bit4	--	Reserved, must be 0.
Bit3	T2C3IF:	Timer2 Compare/Capture Channel 3 Flag Bits;
	1=	Timer2 Compare channel 3 {CCH3:CCL3}={TH2:TL2} or capture channel 3 produces a capture operation that requires software zeroing.
	0=	--
Bit2	T2C2IF:	Timer2 Compare/Capture Channel 2 Flag Bits;
	1=	Timer2 Compare channel 2 {CCH2:CCL2}={TH2:TL2} or capture channel 2 to produce a capture operation that requires software zeroing.
	0=	--
Bit1	T2C1IF:	Timer2 Compare/Capture Channel 1 Flag Bits;
	1=	Timer2 Compare channel 1 {CCH1:CCL1}={TH2:TL2} or capture channel 1 to produce a capture operation that requires software zeroing.
	0=	--
Bit0	T2C0IF:	Timer2 Compare/Capture Channel 0 Flag Bits;
	1=	Timer2 Compare channel 0{RLDH:RLDL}={TH2:TL2} or capture channel 0 produces a capture operation that requires software zeroing.
	0=	--

6.4.3.3 Peripheral Interrupt Flag Bit Register EIF2

0xB2	Bit7	Bit6	Bit5	Bit4	Bit3	Bit2	Bit1	Bit0
EIF2	SPIIF	I2CIF	--	ADCIF	PWMIF	--	TF4	TF3
R/W	R	R	--	R/W	R	--	R/W	R/W
Reset value	0	0	0	0	0	0	0	0

Bit7	SPIIF:	SPI global interrupt indicator bit, read-only;
	1=	SPI generates an interrupt, (this bit is automatically cleared after the specific interrupt flag is cleared);
	0=	The SPI did not produce an interrupt.
Bit6	I2CIF:	I2C global interrupt indicator bit, read-only;
	1=	I2C produces an interrupt, (after clearing the specific interrupt flag, this bit is automatically cleared);
	0=	I2C did not produce an interrupt.
Bit5	--	Reserved, must be 0.
Bit4	ADCIF:	ADC interrupt flag bit;
	1=	ADC conversion is completed, and software zeroing is required;
	0=	The ADC conversion was not completed.
Bit3	PWMIF:	PWM global interrupt indicator bit, read-only;
	1=	PWM generates an interrupt, (after the specific interrupt flag is cleared, this bit is automatically cleared);
	0=	The PWM did not produce an interrupt.
Bit2	--	Reserved, must be 0.
Bit1	TF4:	Timer4 timer overflow interrupt flag bit;
	1=	Timer4 timer overflow, the hardware is automatically cleared when entering the interrupt service program, and the software can also be cleared;
	0=	The Timer4 timer has no overflow.
Bit0	TF3:	Timer3 timer overflow interrupt flag bit;
	1=	Timer3 timer overflow, when entering the interrupt service program, the hardware is automatically cleared, and the software can also be cleared;
	0=	The Timer3 timer has no overflow.

6.4.3.4 SPI Interrupt Flag Bit Register SPSR

0xED	Bit7	Bit6	Bit5	Bit4	Bit3	Bit2	Bit1	Bit0
SPSR	SPISIF	WCOL	--	--	--	--	--	SSCEN
R/W	R	R	--	--	--	--	R/W	R/W
Reset value	0	0	0	0	0	0	0	0

- Bit7 SPISIF: SPI transmission completion interrupt flag bit, read-only;
 1= SPI transmission is completed (read SPSR first, then read/write SPDR and then clear zero);
 0= The SPI was not transmitted.
- Bit6 WCOL: SPI write violation interrupt flag bit, read-only;
 1= When the SPI transfer is not completed, a collision of the write SPDR operation occurs (read the SPSR first, then clear the SPDR after reading/writing the SPDR);
 0= No write conflicts.
- Bit5~Bit1 -- Reserved, must be 0.
- Bit0 SSCEN: SPI master mode NSS output control bit.
 1= When the SPI is idle, the NSS output is high;
 0= NSS output registers the contents of the SSCR.

6.4.3.5 I2C Master Mode Interrupt Flag Registers I2CMCR/I2CMSR

0xF5	Bit7	Bit6	Bit5	Bit4	Bit3	Bit2	Bit1	Bit0
I2CMCR	RSTS	--	--	--	ACK	STOP	START	RUN
I2CMSR	I2CMIF	BUS_BUSY	IDLE	ARB_LOST	DATA_ACK	ADDR_ACK	ERROR	BUSY
R/W	R/W	R/W	R/W	R/W	R/W	R/W	R/W	R/W
Reset value	0	0	0	0	0	0	0	0

- Bit7 RSTS: I2C master module reset control bit;
 1= Reset the master module (I2C registers for the entire master module, including I2CMSR);
 0= The interrupt flag bit in I2C master mode is clear to 0.
- I2CMIF: I2C Master mode interrupt flag bit;
 1= In master mode, send/receive completes, or a transmission error occurs. (Software zero, write 0 to clear);
 0= No interrupt was generated.
- Bit6~Bit0 Control and flag bits in I2C master mode, see I2CM description for details.

6.4.3.6 I2C Slave Mode Status Register I2CSSR

0xF2	Bit7	Bit6	Bit5	Bit4	Bit3	Bit2	Bit1	Bit0
I2CSSR	--	--	--	--	--	SENDFIN	TREQ	RREQ
R/W	--	--	--	--	--	R	R	R
Reset value	0	0	0	0	0	0	0	0

Bit7~Bit3 -- Reserved, must be 0.

Bit2 SENDFIN: I2C slave mode send operation completion flag bit, read-only;

1= The data is no longer required by the master device, the TREQ is no longer set to 1, and the data transfer has been completed. (Automatic zeroing after reading I2CSCR).

0= --

Bit1 TREQ: I2C Slave mode prepares to send flag bits, read-only;

1= As the transmitting device has been addressed or the master device is ready to receive data. (Auto zero after writing I2CSBUF).

0= --

Bit0 RREQ: I2C slave mode receives completion flag bits, read-only;

1= Received. (Automatic zeroing after reading I2CSBUF);

0= Not received.

The relevant status bits for I2C slave mode are also interrupt flag bits

Note: The I2C Master mode interrupt shares the same interrupt vector (00ABH) as the slave mode interrupt

6.4.3.7 UART Control Register SCONn

	Bit7	Bit6	Bit5	Bit4	Bit3	Bit2	Bit1	Bit0
SCONn	UnSM0	UnSM1	UnSM2	UnREN	UnTB8	UnRB8	Believe	RIn
R/W	R/W	R/W	R/W	R/W	R/W	R/W	R/W	R/W
Reset value	0	0	0	0	0	0	0	0

BANK0: Register SCON0 address 0x98; Register SCON1 address 0xEA.

Bit7~Bit2 U1SM0、U1SM1、U1SM2、U1REN、U1TB8、U1RB8:UART1 related control bits, see UARTn function description

Bit1 TIn: Send interrupt flag bits (requires software zeroing);

1= Indicates that the send buffer is empty, and you can send the frame data.

0= --

Bit0 RIn: Receive interrupt flag bits (requires software zeroing);

1= Indicates that the receive buffer is full, and the next frame of data can be received after reading.

0= --

TIn and RIn occupy the same interrupt vector and require a query to determine whether to receive an interrupt or send an interrupt.

6.4.3.8 P0 port Interrupt Flag Register P0EXTIF

0xB4	Bit7	Bit6	Bit5	Bit4	Bit3	Bit2	Bit1	Bit0
P0EXTIF	P07IF	P06IF	P05IF	P04IF	P03IF	P02IF	P01IF	P00IF
R/W	R/W	R/W	R/W	R/W	R/W	R/W	R/W	R/W
Reset value	0	0	0	0	0	0	0	0

Bit7~Bit0 P0iIF: P0i interrupt flag bit (i=0-7);
 1= P0i port produces an interrupt, which requires software clearance;
 0= There is no interrupt in the P0i port.

6.4.3.9 Port P1 Interrupt Flag Register P1EXTIF

0xB5	Bit7	Bit6	Bit5	Bit4	Bit3	Bit2	Bit1	Bit0
P1EXTIF	P17IF	P16IF	P15IF	P14IF	P13IF	P12IF	P11IF	P10IF
R/W	R/W	R/W	R/W	R/W	R/W	R/W	R/W	R/W
Reset value	0	0	0	0	0	0	0	0

Bit7~Bit0 P1iIF: P1i interrupt flag bit (i=0-7);
 1= P1i port produces an interrupt, which requires software clearance;
 0= There is no interrupt in the P1i port.

6.4.3.10 P2 Port Interrupt Flag Bit Register P2EXTIF

0xB6	Bit7	Bit6	Bit5	Bit4	Bit3	Bit2	Bit1	Bit0
P2EXTIF	--	--	--	--	P23IF	P22IF	P21IF	P20IF
R/W	R/W	R/W	R/W	R/W	R/W	R/W	R/W	R/W
Reset value	0	0	0	0	0	0	0	0

Bit7~Bit4 -- Reserved, must be 0.
 Bit3~Bit0 P2iIF: P2i interrupt flag bit (i=0-3);
 1= P2i port produces an interrupt, which requires software clearance;
 0= There is no interrupt in the P2i port.

6.4.3.11 P5 Port Interrupt Flag Bit Register P5EXTIF

0xA7	Bit7	Bit6	Bit5	Bit4	Bit3	Bit2	Bit1	Bit0
P5EXTIF	--	--	P55IF	P54IF	P53IF	P52IF	P51IF	P50IF
R/W	R/W	R/W	R/W	R/W	R/W	R/W	R/W	R/W
Reset value	0	0	0	0	0	0	0	0

Bit7~Bit6 -- Reserved, must be 0.
 Bit5~Bit0 P5iIF: P5i interrupt flag bit (i=0-5);
 1= P5i port produces an interrupt, which requires software clearance;
 0= There is no interrupt in the P5i port.

6.4.4 The Clear Operation For the Interrupt Flag Bit

The clear operation of the interrupt flag is divided into the following categories:

- ◆ Automatic hardware cleanup (requires entry into interrupt service)
- ◆ Software cleanup
- ◆ Read/write operations are cleared

1) The hardware automatically clears the flag bits

The bits that support hardware auto-clearing are the interrupt flag bits generated by IN0, INT1, T0, T1, T3, and T4. The condition for the hardware to automatically clear the flag is: open the global interrupt enable bit EA=1, and open the corresponding interrupt enable bit, after the interrupt is generated, the system enters the corresponding interrupt service program, and the flag bit is automatically cleared. If interrupt enables shutdown, these flags can also be cleared using software.

2) The flag bits that the software clears

There are flags in the system that can only be cleared with software. These flags are not automatically cleared after entering the interrupt service program and require the software to write 0 to clear. Otherwise, after exiting the interrupt service program, you will enter the interrupt service program again.

3) The flag bit cleared by the R/W operations

The flag bit in the system is not written to zero to the flag bit, but requires reading/writing other registers to clear the flag bit. For example, if the transmission completion flag bit SPISIF in the SPI interrupt flag register is set to 1, you need to read `spcr` first, and then read/write `SPDR` and then clear zero.

Software cleanup operations require attention: when multiple interrupt flags are in the same register, and the moments these flags are generated are not related to each other, it is not recommended to use read-modify-write operations. For example, the `PWMZIF` interrupt flag register, which contains the zero interrupt of the PG0-PG5 channel, these interrupt flag bits are not related to each other. When PG0 produces an zero interrupt, the value of `PWMZIF` is 0x01, and a read-modify-write operation clears the bit after entering the interrupt service program.

```
PWMZIF &= 0xFE;
```

This operation is implemented by reading the value of `PWMZIF` back to the CPU, then performing the operation, and finally sending it back to `PWMZIF`. If the interrupt flag bit `PWMZIF[1]` of PG1 is set to 1 after the CPU read, and `PWMZIF[1]` is 0 when read, the operation is performed and sent back to `PWMZIF[1]` is also 0, at which point the zero interrupt flag bit `PWMZIF[1]` that PG1 has generated will be cleared.

Clear the interrupt flag bits of the above type, it is recommended to write 0 directly, other unrelated flag bits to write 1: `PWMZIF = 0xFE`. This operation has no practical effect on unrelated interrupt flag write 1.

6.4.5 Special Interrupt Flag Bits in Debug Mode

The flag bit in the system is not written to zero to the flag bit, but requires reading/writing other registers to clear the flag bit.

In debug mode, after breakpoint execution, step-through, or stop operation, the emulator reads out all register values from the system to the emulation software, and the emulator reads/writes exactly the same as in normal mode.

So during debugging, after a pause occurs, the break flag bit of a set of 1 should appear, but it is displayed as 0 in the observation window.

Example: The transmit completion flag bit SPISIF in the SPI interrupt flag register in debug mode

```
...// Set the port and interrupt enable
SPDR = 0x56; Send SPDR data
delay();
...

void SPI_int (void) interrupt SPI_VECTOR// SPI interrupt service program
{
    O1  _nop_(); Set breakpoint 1
        _nop_();
    O2  k = SPSR; Set breakpoint 2
        _nop_();
    ...
}
```

When the breakpoint is running, stop after breakpoint 1, SPI completes the transmit operation, and the transmit completion interrupt has been generated, so SPSR.7=1, at which point the emulator has completed the operation of reading all the registers at once (including reading SPSR),

Perform the breakpoint run again, stop after breakpoint 2, at which point the emulator again finishes reading all registers (including SPDR), so SPSR.7=0. The above situation can also occur when you step into it twice, which requires attention in debug mode.

7. I/O Port

7.1 GPIO Function

The chip has four sets of I/O ports: PORT0, PORT1, PORT2, PORT5.

PORTx is a bidirectional port. Its corresponding data direction register is PxTRIS. A bit set to 1 (=1) of the PxTRIS allows the corresponding pin to be configured as an output. Zeroing one bit of PxTRIS (= 0) configures the corresponding POLTx pin as the input.

When PORTx is used as an output port, the write Px register will write to the port latch, and all write operations are read-modify-write operations. Therefore, writing a port means reading the pin level of that port, then modifying the value read, and finally writing the changed value to the port data latch.

When PORTx is used as an output port, the Px register is read, which is related to the setting of the PxDS register. One position of PxDS 1 (=1), the corresponding bit of Px read is the state of the pin, one bit of PxDS is cleared to zero out (=0), and the corresponding bit of Px read is the state of the port data latch; When PORTx is used as an input port, the Px register reads the state of the pin, regardless of the setting of the PxDS register.

When using the POLTx pin as an analog input, the user must ensure that the bits in the PxTRIS register remain in the set 0 state. I/O pins configured as analog inputs are always read as 0.

Registers related to PORTx ports include Px, PxTRIS, PxOD, PxUP, PxD, PxRD, PxDS, etc.

7.1.1 PORTx Data Register Px

	Bit7	Bit6	Bit5	Bit4	Bit3	Bit2	Bit1	Bit0
Px	Px7	Px6	Px5	Px4	Px3	Px2	Px1	Px0
R/W	R/W	R/W	R/W	R/W	R/W	R/W	R/W	R/W
Reset value	X	X	X	X	X	X	X	X

Register P0 Address: 0x80; Register P1 Address: 0x90; Register P2 Address: 0xA0; Register P5 address: 0xD8.

Bit7~Bit0 Px<7:0>: Px I/O pin bits;
 1= Port pin level >V_{IH} (forward threshold voltage);
 0= The port pin level < V_{IL} (negative threshold voltage).

7.1.2 PORTx Direction Register PxTRIS

	Bit7	Bit6	Bit5	Bit4	Bit3	Bit2	Bit1	Bit0
PxTRIS	PxTRIS7	PxTRIS6	PxTRIS5	PxTRIS4	PxTRIS3	PxTRIS2	PxTRIS1	PxTRIS0
R/W	R/W	R/W	R/W	R/W	R/W	R/W	R/W	R/W
Reset value	0	0	0	0	0	0	0	0

Register P0TRIS Address: 0x9A; Register P1TRIS Address: 0xA1; Register P2TRIS Address: 0xA2; Register P5TRIS address: 0xA5.

Bit7~Bit0 PxTRIS<7:0>: Three-state control bit;
 1= The pins are configured as outputs;
 0= The pins are configured as inputs (tri-state).

Note:

- 1) When a port is set to an output port, the data that reads the port is the value of the output register.
- 2) After the port is set to the input port, the < read-modify-write instructions of the > type to the port are actually operations on the output registers.

7.1.3 PORTx Open-drain Control Register PxOD

	Bit7	Bit6	Bit5	Bit4	Bit3	Bit2	Bit1	Bit0
PxOD	PxOD7	PxOD6	PxOD5	PxOD4	PxOD3	PxOD2	PxOD1	PxOD0
R/W	R/W	R/W	R/W	R/W	R/W	R/W	R/W	R/W
Reset value	0	0	0	0	0	0	0	0

Register P0OD Address: F009H; Register P1OD Address: F019H; Register P2OD Address: F029H; Register P5OD address: F059H.

- Bit7~Bit0 PxOD<7:0>: Open-drain control bit;
- 1= The pins are configured for an open-drain state (the output is an open-drain output);
 - 0= The pins are configured for a normal state (the output is a push-pull output).

7.1.4 PORTx pull-up Resistor Control Register PxUP

	Bit7	Bit6	Bit5	Bit4	Bit3	Bit2	Bit1	Bit0
PxUP	PxUP7	PxUP6	PxUP5	PxUP4	PxUP3	PxUP2	PxUP1	PxUP0
R/W	R/W	R/W	R/W	R/W	R/W	R/W	R/W	R/W
Reset value	0	0	0	0	0	0	0	0

Register P0UP Address: F00AH; Register P1UP Address: F01AH; Register P2UP Address: F02AH; Register P5UP address: F05AH.

- Bit7~Bit0 PxUP<7:0>: Pull-up resistor control bit;
- 1= Pin pull-up resistor on;
 - 0= The pin pull-up resistor is off.

7.1.5 PORTx Pull-down Resistor Control Register PxRD

	Bit7	Bit6	Bit5	Bit4	Bit3	Bit2	Bit1	Bit0
PxRD	PxRD7	PxRD6	PxRD5	PxRD4	PxRD3	PxRD2	PxRD1	PxRD0
R/W	R/W	R/W	R/W	R/W	R/W	R/W	R/W	R/W
Reset value	0	0	0	0	0	0	0	0

Register P0RD address: F00BH; Register P1RD address: F01BH; Register P2RD address: F02BH; Register P5RD address: F05BH.

- Bit7~Bit0 PxRD<7:0>: Pull-down resistor control bit;
- 1= Pin pull-down resistor open;
 - 0= Pin pull-down resistor off.

Note: The control of the pull-down resistor is independent of the configuration and multiplexing function of the GPIO and is controlled separately by the PxRD registers.

7.1.6 PORTx Slope Control Register PxSR

	Bit7	Bit6	Bit5	Bit4	Bit3	Bit2	Bit1	Bit0
PxSR	PxSR7	PxSR6	PxSR5	PxSR4	PxSR3	PxSR2	PxSR1	PxSR0
R/W	R/W	R/W	R/W	R/W	R/W	R/W	R/W	R/W
Reset value	0	0	0	0	0	0	0	0

Register P0SR Address: F00DH; Register P1SR Address: F01DH; Register P2SR Address: F02DH; Register P5SR address: F05DH.

- Bit7~Bit0 PxSR<7:0>: Px slope control register (in effect when the port is configured for output state);
- 1= The Px pin is slow slope;
 - 0= The Px pin is fast slope.

7.1.7 The PORTx Data Input Selects Register PxDS

	Bit7	Bit6	Bit5	Bit4	Bit3	Bit2	Bit1	Bit0
PxDS	PxDS7	PxDS6	PxDS5	PxDS4	PxDS3	PxDS2	PxDS1	PxDS0
R/W	R/W	R/W	R/W	R/W	R/W	R/W	R/W	R/W
Reset value	0	0	0	0	0	0	0	0

Register P0DS Address: F00EH; Register P1DS Address: F01EH; Register P2DS Address: F02EH; Register P5DS address: F05EH.

- Bit7~Bit0 PxDS<7:0>: Data input selection bits that affect the value of the reading Px register when configured for GPIO;
- 1= Both output/input modes read pin status;
(The Smit circuit also remains open when the port is set to output);
 - 0= Output mode: read to data latch state;
Input Mode: Reads to pin state.

Note: If you need to read the pin state of the port when it is a multiplexing function input structure, you need to set the port direction control to input mode.

7.2 Multiplexed Functions

7.2.1 Port Multiplexing Feature Table

Pins are shared in a variety of functions, and each I/O port can be flexibly configured with digital functions or specified analog functions. The digital function of the external input is selected by the port input function allocation register (PS_XX); The multiplexing function is selected by the port multiplexing function configuration register (PxnCFG), where the communication input function is also specified by the communication input function allocation register (PS_XX).

The digital function configuration is shown in the following table:

	External input	Digital function configuration							
		0	1	2	3	4	5	6	7
P00	-	GPIO	ANA	SCL	SCLK	CC0	PG0	TXD1	RXD1
P01	-	GPIO	ANA	SDA	MOSI	CC1	PG1	TXD1	RXD1
P02	T0G/T1G/T2EX	GPIO	ANA	-	MISO	CC2	PG2	TXD1	RXD1
P03	T0/T1/T2	GPIO	ANA	-	NSS(NSSO0)	CC3	PG3	TXD1	RXD1
P04	-	GPIO	ANA	TXD0	NSS(NSSO1)	-	PG4	TXD1	RXD1
P05	-	GPIO	ANA	RXD0	NSS(NSSO2)	-	PG5	TXD1	RXD1
P06	MOQ/INT0	GPIO	ANA	-	NSS(NSSO3)	BUZZ	-	TXD1	RXD1
P07	INT0/INT1	GPIO	ANA	-	-	CLO	-	TXD1	RXD1
P10	-	GPIO	ANA	SCL	SCLK	-	PG0	TXD1	RXD1
P11	-	GPIO	ANA	SDA	MOSI	-	PG1	TXD1	RXD1
P12	T0G/T1G/T2EX	GPIO	ANA	-	MISO	-	PG2	TXD1	RXD1
P13	T0/T1/T2	GPIO	ANA	-	NSS(NSSO0)	-	PG3	TXD1	RXD1
P14	CAP0	GPIO	ANA	TXD0	NSS(NSSO1)	-	PG4	TXD1	RXD1
P15	CAP1	GPIO	ANA	RXD0	NSS(NSSO2)	-	PG5	TXD1	RXD1
P16	CAP2	GPIO	ANA	-	NSS(NSSO3)	BUZZ	-	TXD1	RXD1
P17	CAP3	GPIO	ANA	-	-	CLO	-	TXD1	RXD1
P20	-	GPIO	ANA	SCL	SCLK	CC0	PG0	TXD1	RXD1
P21	-	GPIO	ANA	SDA	MOSI	CC1	PG1	TXD1	RXD1
P22	T0G/T1G/T2EX	GPIO	ANA	-	MISO	CC2	PG2	TXD1	RXD1
P23	T0/T1/T2	GPIO	ANA	-	NSS(NSSO0)	CC3	PG3	TXD1	RXD1
P50	NSRT	GPIO	ANA	SCL	SCLK	-	PG0	TXD1	RXD1
P51	-	GPIO	ANA	SDA	MOSI	-	PG1	TXD1	RXD1
P52	-	GPIO	ANA	-	MISO	-	PG2	TXD1	RXD1
P53	-	GPIO	ANA	-	NSS(NSSO0)	-	PG3	TXD1	RXD1
P54	-	GPIO	ANA	TXD0	NSS(NSSO1)	-	PG4	TXD1	RXD1
P55	-	GPIO	ANA	RXD0	NSS(NSSO2)	-	PG5	TXD1	RXD1

LED port assignment, analog module, CONFIG configuration ports are shown in the following table:

	GPIO(0)			ANA(1)					CONFIG
	LEDSEG	LEDCOM	LEDx	ADC	TOUCH				
P00	-	COM0	LED0	AN0	TK0				-
P01	-	COM1	LED1	AN1	TK1				-
P02	-	COM2	LED2	AN2	TK2				-
P03	-	COM3	LED3	AN3	TK3				-
P04	SEG0	COM4	LED4	AN4	TK4				-
P05	SEG1	COM5	LED5	AN5	TK5				-
P06	SEG2	COM6	LED6	AN6	TK6				-
P07	SEG3	COM7	LED7	AN7	TK7				-
P10	SEG4	-	LED8	AN8	TK8				-
P11	SEG5	-	-	AN9	TK9				-
P12	SEG6	-	-	AN10	TK10				-
P13	SEG7	-	-	AN11	TK11				-
P14	SEG8	-	-	AN12	TK12				-
P15	SEG9	-	-	AN13	TK13				-
P16	SEG10	-	-	AN14	TK14				-
P17	SEG11	-	-	AN15	TK15				-
P20	SEG12	-	-	AN16	TK16				-
P21	SEG13	-	-	AN17	TK17				-
P22	SEG14	-	-	AN18	TK18				-
P23	SEG15	-	-	AN19	TK19				-
P50	-	-	-	AN39	TK39				NRST
P51	-	-	-	AN40	TK40				OSCIN
P52	-	-	-	AN41	TK41				OSCOUT
P53	-	-	-	AN42	TK42				DSDA
P54	-	-	-	AN43	TK43				DSCK
P55	-	-	-	AN44	TK44				-

7.2.2 Port Multiplexing Feature Configuration Register

The PORTx function configuration register PxnCFG

	Bit7	Bit6	Bit5	Bit4	Bit3	Bit2	Bit1	Bit0
PxnCFG	--	--	--	--	--	PxnCFG2	PxnCFG1	PxnCFG0
R/W	--	--	--	--	--	R/W	R/W	R/W
Reset value	0	0	0	0	0	0	0	1

Bit7~Bit3 -- Reserved, must be 0.

Bit2~Bit0 PxnCFG<2:0>: Feature configuration bit, the default simulation is a function. For details, see port function configuration instructions;

000= GPIO function;

001= Analog Function (ANA);

Other = Multiplexing function;

PxnCFG x=0/1/2/5,n=0-7

Each port has a function configuration register, PxnCFG, through which each port can be set to the corresponding digital function. For example: to set P16 as BEEP buzzer function, configure it as: P16CFG = 0x04;

When the port is multiplexed, there is no need to configure the port direction register PxTRIS.

- SCL and SDA pull-up resistance registers can be configured to force open drain output.

- RXD0 and RXD1 synchronization modes enable pull-up forcibly.

For other multiplexing functions, the hardware forcibly turns off the pull-up resistor and the open drain output, that is, the software sets the pull-up resistor PxUP or the open drain output PxOD to be invalid.

When the port is multiplexed to SCL and SDA functions, the hardware forces the port to open drain output, and the pull-up resistance PxUP can be set through software.

7.2.3 The Port Input Function Allocation Registers

Inside the chip there are digital functions with only the input state, such as INT0/INT1... etc., this type of digital input function is independent of the port multiplexing state. As long as the assigned port supports digital input (such as RXD0 as a digital input and GPIO as an input function), the port supports this function.

The input function port assignment registers are as follows:

register	address	function	Feature description
PS_INT0	F0C0H	INT0	External interrupt 0 input port allocation register
PS_INT1	F0C1H	INT1	External interrupt 1 input port allocation register
PS_T0	F0C2H	T0	Timer0 external clock input port assignment register
PS_T0G	F0C3H	T0G	Timer0 gated input port assignment register
PS_T1	F0C4H	T1	Timer1 external clock input port assignment register
PS_T1G	F0C5H	T1G	Timer1 gated input port assignment register
PS_T2	F0C6H	T2	Timer2 external event or gated input port assignment register
PS_T2EX	F0C7H	T2EX	Timer2 drops along the autoreload input port allocation register
PS_CAP0	F0C8H	CAP0	The Timer2 input captures channel 0 port assignment registers
PS_CAP1	F0C9H	CAP1	The Timer2 input captures the channel 1 port assignment register

from high to low.

- 7) The output capability of a communication port has no priority restrictions, and if multiple ports are configured with the same output capability, the functionality outputs simultaneously on those ports.
- 8) The RXD0/1 of the UART0/1 is selected by the port allocation register as an input function, and the port allocation register is independent of the synchronous output function. That is, when the RXD1 is used as a synchronous output function, multiple pins can be selected as RXD0/1 outputs at the same time.
- 9) When the SPI's SCLK is used as the clock input of the slave, it needs to be selected by the port allocation register, and the clock output of the master is independent of the port allocation register, and it is recommended that the SCLK be configured as both an output and an input.
- 10) When the SCL of the IIC is used as the clock input of the slave, it needs to be selected by the port allocation register. When it is used as the clock output of the host, it is related to the port allocation register. It is recommended that the SCL be configured with the port allocation register whether it is used as the output or input.

8. Watchdog Timer (WDT)

8.1 Overview

The Watch Dog Timer is an on-chip timer with configurable overflow time and clock source provided by the system clock F_{sys} .

When the watchdog timer counts to the configured overflow value, a watchdog overflow interrupt flag bit (WDTIF=1) is generated. If the global interrupt is enabled (EA=1) and the watchdog timer is disabled (EIE2[5]=1), the CPU executes the interrupt service program to clear the watchdog counter through the write register WDCON[0]=1. After the watchdog counter clears, the counter starts counting from 0 again until the next timer overflows.

When the watchdog timer overflows, if the watchdog overflow reset enable (WDCON[1]=1) and the watchdog counter is not cleared, an overflow reset of the watchdog is generated. Watchdog overflow reset is a protective setting of the system, when the system is running to an unknown state, the watchdog can be used to reset the system, thereby avoiding the system from entering an indefinite dead loop. Watchdog overflow reset is detailed in the Reset section.

8.2 Related Registers

8.2.1 Watchdog Control Register WDCON

0x97	Bit7	Bit6	Bit5	Bit4	Bit3	Bit2	Bit1	Bit0
WDCON	SWRST	PORF	--	--	WDTIF	WDTRF	WDTRE	WDTCLR
R/W	R/W	R/W	R	R	R/W	R/W	R/W	R/W
Reset value	0	1	0	0	0	0	0	0

Bit7	SWRST:	Software reset control bit; 1: Perform a system software reset (write 0 clear after reset). 0: --
Bit6	PORF:	Power-on reset marker; 1: The system resets the system at power-on (write 0 clear, do not need TA to write timing). 0: --
Bit5~Bit4	--	Reserved, must be 0.
Bit3	WDTIF:	WDT overflow interrupt flag bit; 1= WDT overflow (write 0 cleared); 0= WDT does not overflow.
Bit2	WDTRF:	WDT reset marker bit; 1= The system is reset by WDT (write 0 cleared); 0= The system is not reset by WDT.
Bit1	WDTRE:	WDT reset enable bit; 1= Enable WDT reset CPU; 0= Disable WDT reset cpu.
Bit0	WDTCLR:	WDT counter clear bit; 1= Clear WDT counter (hardware auto-zero); 0= Disables the WDT counter (write 0 is invalid).

Note:

1. If the WDT in CONFIG is configured as: ENABLE, the WDT is always enabled, regardless of the state of the WDTRE control bit. And the overflow reset function of WDT is forced on.
2. If WDT in CONFIG is configured as: SOFTWARE CONTROL, WDTRE can be enabled or disabled using the WDTRE control bit.

Modify the sequence of instructions required by WDCON (no other instructions can be inserted in the middle):

```
MOV      TA,#0AAH
MOV      TA,#055H
ORL      WDCON,#01H
```

8.2.2 Watchdog Overflow Control Register CKCON

0x8E	Bit7	Bit6	Bit5	Bit4	Bit3	Bit2	Bit1	Bit0
CKCON	WTS2	WTS1	WTS0	T1M	T0M	--	--	--
R/W	R/W	R/W	R/W	R/W	R/W	R/W	R/W	R/W
Reset value	0	0	0	0	0	1	1	1

Bit7~Bit5	WTS<2:0>:	WDT overflow time selection bits;
	000=	$2^{17} \cdot T_{sys}$;
	001=	$2^{18} \cdot T_{sys}$;
	010=	$2^{19} \cdot T_{sys}$;
	011=	$2^{20} \cdot T_{sys}$;
	100=	$2^{21} \cdot T_{sys}$;
	101=	$2^{22} \cdot T_{sys}$;
	110=	$2^{24} \cdot T_{sys}$;
	111=	$2^{26} \cdot T_{sys}$.
Bit4	T1M:	Timer1's clock source select bit;
	0=	$F_{sys}/12$;
	1=	$F_{sys}/4$.
Bit3	T0M:	Clock source select bit of Timer0;
	0=	$F_{sys}/12$;
	1=	$F_{sys}/4$.
Bit2~Bit0	--	Reserved, must be 1.

8.3 WDT Interrupt

The watchdog timer can enable or disable interrupts via the EIE2 register, and the high/low priority is set via the EIP2 register, where the relevant bits are described as following.

8.3.1 Interrupt Mask Register EIE2

0xAA	Bit7	Bit6	Bit5	Bit4	Bit3	Bit2	Bit1	Bit0
EIE2	SPIIE	I2CIE	WDTIE	ADCIE	PWMIE	--	ET4	ET3
R/W	R/W	R/W	R/W	R/W	R/W	R/W	R/W	R/W
Reset value	0	0	0	0	0	0	0	0

- Bit7 SPIIE: SPI interrupt enable bit;
 1= Enable SPI interrupts;
 0= Prohibited SPI Interrupt.
- Bit6 I2CIE: I2C interrupt enable bit;
 1= Enable I2C interrupts;
 0= Disable I²C interrupt.
- Bit5 WDTIE: WDT interrupt enable bit;
 1= Enable WDT overflow interrupts;
 0= Disable WDT overflow interrupts.
- Bit4 ADCIE: ADC interrupt enable bit;
 1= Enable ADC interrupts;
 0= Prohibited ADC interrupts.
- Bit3 PWMIE: PWM global interrupt enable bit;
 1= Enable all PWM interrupts;
 0= Disable all PWM interrupts.
- Bit2 -- Reserved, must be 0.
- Bit1 ET4: Timer4 interrupt enable bit;
 1= Enable Timer4 interrupts;
 0= Disable Timer4 Interrupt.
- Bit0 ET3: Timer3 interrupt enable bit;
 1= Enable Timer3 interrupts;
 0= Disable Timer3 interrupt.

8.3.2 Interrupt Priority Control Register EIP2

0xBA	Bit7	Bit6	Bit5	Bit4	Bit3	Bit2	Bit1	Bit0
EIP2	PSPI	PI2C	PWDT	PADC	PPWM	PLED	PT4	PT3
R/W	R/W	R/W	R/W	R/W	R/W	R/W	R/W	R/W
Reset value	0	0	0	0	0	0	0	0

- Bit7 PSPI: SPI interrupt priority control bit;
 1= Set to High-level Interrupt;
 0= Set to low-level interrupt.
- Bit6 PI2C: I2C interrupt priority control bit;
 1= Set to High-level Interrupt;
 0= Set to low-level interrupt.
- Bit5 PWDT: WDT interrupt priority control bit;
 1= Set to High-level Interrupt;
 0= Set to low-level interrupt.
- Bit4 PADC: ADC interrupt priority control bit;
 1= Set to High-level Interrupt;
 0= Set to low-level interrupt.
- Bit3 PPWM: PWM interrupt priority control bit
 1= Set to High-level Interrupt;
 0= Set to low-level interrupt.
- Bit2 PLED: LED dot matrix scan interrupt priority control bit
 1= Set to High-level Interrupt;
 0= Set to low-level interrupt.
- Bit1 PT4: TIMER4 interrupt priority control bit;
 1= Set to High-level Interrupt;
 0= Set to low-level interrupt.
- Bit0 PT3: TIMER3 interrupt priority control bit;
 1= Set to High-level Interrupt;
 0= Set to low-level interrupt.

9. Timer Counter 0/1 (Timer0/1)

Timer 0 is similar in type and structure to Timer 1 and is two 16-bit timers. Timer 1 has three modes of operation and Timer 0 has four modes of operation. They provide basic timing and event counting operations.

In "timer mode", the timing register is incremented every 12 or 4 system cycles when the timer clock is enabled.

In "counter mode", the timing register increments whenever it detects a falling edge on the corresponding input pin (T0 or T1).

9.1 Overview

Timer 0 and Timer 1 are fully compatible with the standard 8051 timer.

Each timer consists of two 8-bit registers: {TH0(0x8C):TL0(0x8A)} and {TH1(0x8D):TL1(0x8B)}. Timers 0 and 1 operate in four identical modes. The Timer0 and Timer1 modes are described below.

mode	M1	M0	Feature description
0	0	0	THx [7:0], TLx [4:0] form a 13-bit timer/counter
1	0	1	THx [7:0], TLx [7:0] form a 16-bit timer/counter
2	1	0	TLx [7:0] consists of an 8-bit auto-reload timer/counter that is reloaded from THx
3	1	1	TL0, TH0 are two 8-bit timers/counters, and Timer1 stops counting

The registers THx and TLx are special function registers with the function of storing the actual timer values. THx and TLx can be cascaded into 13-bit or 16-bit registers via mode options. Each time an internal clock pulse or an external timer pin is received, the value of the register is incremented by 1. The timer starts counting from the value contained in the preset register until the timer is full till overflow, at which point an internal interrupt signal is generated. If auto-overload mode is selected for the timer, the value of the timer is reset to the initial value of the preload register and continues counting, otherwise the value of the timer is reset to zero. Note that in order to get the maximum calculation range of the timing/counter, the preset registers must first be cleared to zero.

9.2 Related Registers

9.2.1 Timer0/1 Mode Register TMOD

0x89	Bit7	Bit6	Bit5	Bit4	Bit3	Bit2	Bit1	Bit0
TMOD	GATE1	CT1	T1M1	T1M0	GATE0	CT0	T0M1	T0M0
R/W	R/W	R/W	R/W	R/W	R/W	R/W	R/W	R/W
Reset value	0	0	0	0	0	0	0	0

Bit7	GATE1: Timer 1 gate control bit; 1= Enable; 0= Disable.
Bit6	CT1: Timer 1 timing/count select bits; 1= Count; 0= Timing.
Bit5~Bit4	T1M<1:0>: Timer 1 mode select bit; 00= Mode 0, 13-bit timer/counter; 01= Mode 1, 16-bit timer/counter; 10= Mode 2, 8-bit automatic reload timer/counter; 11= Mode 3, Stop Count.
Bit3	GATE0: Timer 0 gate control bit; 1= Enable; 0= Disable.
Bit2	CT0: Timer 0 Timing/Count Select Bits; 1= Count; 0= Timing.
Bit1~ Bit0	T0M<1:0>: Timer 0 mode select bit; 00= Mode 0, 13-bit timer/counter; 01= Mode 1, 16-bit timer/counter; 10= Mode 2, 8-bit automatic reload timer/counter; 11= Mode 3, two independent 8-bit timers/counters.

9.2.2 Timer0/1 Control Register TCON

0x88	Bit7	Bit6	Bit5	Bit4	Bit3	Bit2	Bit1	Bit0
TCON	TF1	TR1	TF0	TR0	IE1	IT1	IE0	IT0
R/W	R/W	R/W	R/W	R/W	R/W	R/W	R/W	R/W
Reset value	0	0	0	0	0	0	0	0

- Bit7 TF1: Timer1 counter overflow interrupt flag bit;
 1= The Timer1 counter overflows and enters the interrupt service program hardware to automatically zero;
 0= The Timer1 counter has no overflow.
- Bit6 TR1: Timer1 operational control bit;
 1= Timer1 starts;
 0= Timer1 is off.
- Bit5 TF0: Timer0 counter overflow interrupt flag bit;
 1= The Timer0 counter overflows, entering the interrupt service program hardware to automatically zero;
 0= The Timer0 counter has no overflow.
- Bit4 TR0: Timer0 operational control bit;
 1= Timer0 starts;
 0= Timer0 closes.
- Bit3 IE1: External interrupt 1 flag;
 1= External interrupt 1 generates an interrupt, and the hardware of the interrupt service program is automatically cleared;
 0= External interrupt 1 did not produce an interrupt.
- Bit2 IT1: External interrupt 1 trigger mode control bit;
 1= Falling edge trigger;
 0= Low level triggering.
- Bit1 IE0: External interrupt 0 flag;
 1= External interrupt 0 generates an interrupt, and the hardware entering the interrupt service program is automatically cleared;
 0= External interrupt 0 did not produce an interrupt.
- Bit0 IT0: External interrupt 0 trigger mode control bit;
 1= Falling edge trigger;
 0= Low level triggering.

9.2.3 Timer0 Data Register Low Bit TL0

0x8A	Bit7	Bit6	Bit5	Bit4	Bit3	Bit2	Bit1	Bit0
TL0	TL07	TL06	TL05	TL04	TL03	TL02	TL01	TL00
R/W	R/W	R/W	R/W	R/W	R/W	R/W	R/W	R/W
Reset value	0	0	0	0	0	0	0	0

Bit7~Bit0 TL0<7:0>: Timer 0 low data register (also as counter low).

9.2.4 Timer0 Data Register High Bit TH0

0x8C	Bit7	Bit6	Bit5	Bit4	Bit3	Bit2	Bit1	Bit0
TH0	TH07	TH06	TH05	TH04	TH03	TH02	TH01	TH00
R/W	R/W	R/W	R/W	R/W	R/W	R/W	R/W	R/W
Reset value	0	0	0	0	0	0	0	0

Bit7~Bit0 TH0<7:0>: Timer 0 high bit data register (also as counter high bit).

9.2.5 Timer1 Data Register Low Bit TL1

0x8B	Bit7	Bit6	Bit5	Bit4	Bit3	Bit2	Bit1	Bit0
TL1	TL17	TL16	TL15	TL14	TL13	TL12	TL11	TL10
R/W	R/W	R/W	R/W	R/W	R/W	R/W	R/W	R/W
Reset value	0	0	0	0	0	0	0	0

Bit7~Bit0 TL1<7:0>: Timer 1 low bit data register (also as counter low bit).

9.2.6 Timer1 Data Register High TH1

0x8D	Bit7	Bit6	Bit5	Bit4	Bit3	Bit2	Bit1	Bit0
TH1	TH17	TH16	TH15	TH14	TH13	TH12	TH11	TH10
R/W	R/W	R/W	R/W	R/W	R/W	R/W	R/W	R/W
Reset value	0	0	0	0	0	0	0	0

Bit7~Bit0 TH1<7:0>: Timer 1 high-bit data register (also as counter high-bit).

9.2.7 Function Clock Control Register CKCON

0x8E	Bit7	Bit6	Bit5	Bit4	Bit3	Bit2	Bit1	Bit0
CKCON	WTS2	WTS1	WTS0	T1M	T0M	--	--	--
R/W	R/W	R/W	R/W	R/W	R/W	R/W	R/W	R/W
Reset value	0	0	0	0	0	1	1	1

Bit7~Bit5 WTS<2:0>: WDT overflow time selection bits;
 000= $2^{17} \cdot T_{sys}$;
 001= $2^{18} \cdot T_{sys}$;
 010= $2^{19} \cdot T_{sys}$;
 011= $2^{20} \cdot T_{sys}$;
 100= $2^{21} \cdot T_{sys}$;
 101= $2^{22} \cdot T_{sys}$;
 110= $2^{24} \cdot T_{sys}$;
 111= $2^{26} \cdot T_{sys}$.
 Bit4 T1M: Timer1's clock source select bit;
 0= $F_{sys}/12$;
 1= $F_{sys}/4$.
 Bit3 T0M: Clock source select bit of Timer0;
 0= $F_{sys}/12$;
 1= $F_{sys}/4$.
 Bit2~Bit0 -- Reserved, must be 1.

9.3 Timer0/1 Interrupt

Timer0/1 can enable or disable interrupts via the IE register, and can also set high/low priority via the IP register, where the relevant bits are described as following:

9.3.1 Interrupt Mask Register IE

0xA8	Bit7	Bit6	Bit5	Bit4	Bit3	Bit2	Bit1	Bit0
IE	SHE	ES1	ET2	ES0	ET1	EX1	ET0	EX0
R/W	R/W	R/W	R/W	R/W	R/W	R/W	R/W	R/W
Reset value	0	0	0	0	0	0	0	0

Bit7	SHE: Global interrupt enable bits; 1= Enable all unblocked interrupts; 0= Disable all interrupts.
Bit6	ES1: UART1 interrupt enable bit; 1= Enable UART1 interrupt; 0= Disable UART1 Interrupt.
Bit5	ET2: TIMER2 Global interrupt Enable bits; 1= Enable timer2 all interrupts; 0= Disable all TIMER2 interrupts.
Bit4	ES0: UART0 interrupt enable bit; 1= Enable UART0 interrupts; 0= Disable UART0 Interrupt.
Bit3	ET1: TIMER1 interrupt enable bit; 1= Enable TIMER1 interrupts; 0= Prohibited TIMER1 interrupt.
Bit2	EX1: External interrupt 1 interrupt enable bits; 1= Enable external interrupt 1 interrupt; 0= Disable external interrupt 1 interrupt.
Bit1	ET0: TIMER0 interrupt enable bits; 1= Enable TIMER0 interrupts; 0= Prohibited TIMER0 interrupts.
Bit0	EX0: External interrupt 0 interrupt enable bit; 1= Enable external interrupt 0 interrupts; 0= Disable external interrupt 0 interrupt.

9.3.2 Interrupt Priority Control Register IP

0xB8	Bit7	Bit6	Bit5	Bit4	Bit3	Bit2	Bit1	Bit0
IP	--	PS1	PT2	PS0	PT1	PX1	PT0	PX0
R/W	R/W	R/W	R/W	R/W	R/W	R/W	R/W	R/W
Reset value	0	0	0	0	0	0	0	0

- Bit7 -- Reserved, must be 0.
- Bit6 PS1: UART1 interrupt priority control bit;
 1= Set to High-level Interrupt;
 0= Set to low-level interrupt.
- Bit5 PT2: TIMER2 interrupt priority control bit;
 1= Set to High-level Interrupt;
 0= Set to low-level interrupt.
- Bit4 PS0: UART0 interrupt priority control bit;
 1= Set to High-level Interrupt;
 0= Set to low-level interrupt.
- Bit3 PT1: TIMER1 interrupt priority control bit;
 1= Set to High-level Interrupt;
 0= Set to low-level interrupt.
- Bit2 PX1: External interrupt 1 interrupt priority control bit;
 1= Set to High-level Interrupt;
 0= Set to low-level interrupt.
- Bit1 PT0: TIMER0 interrupt priority control bit;
 1= Set to High-level Interrupt;
 0= Set to low-level interrupt.
- Bit0 PX0: External interrupt 0 interrupt priority control bit;
 1= Set to High-level Interrupt;
 0= Set to low-level interrupt.

9.3.3 Timer0/1, INT0/1 Interrupt Flag Bit Register TCON

0x88	Bit7	Bit6	Bit5	Bit4	Bit3	Bit2	Bit1	Bit0
TCON	TF1	TR1	TF0	TR0	IE1	IT1	IE0	IT0
R/W	R/W	R/W	R/W	R/W	R/W	R/W	R/W	R/W
Reset value	0	0	0	0	0	0	0	0

- Bit7 TF1: Timer1 counter overflow interrupt flag bit;
 1= Timer1 counter overflow, when entering the interrupt service program, the hardware is automatically cleared, and the software can also be cleared;
 0= The Timer1 counter has no overflow.
- Bit6 TR1: Timer1 operational control bit;
 1= Timer1 starts;
 0= Timer1 is off.
- Bit5 TF0: Timer0 counter overflow interrupt flag bit;
 1= Timer0 counter overflow, when entering the interrupt service program, the hardware is automatically cleared, and the software can also be cleared;
 0= The Timer0 counter has no overflow.
- Bit4 TR0: Timer0 operational control bit;
 1= Timer0 starts;
 0= Timer0 closes.
- Bit3 IE1: External interrupt 1 flag;
 1= External interrupt 1 generates an interrupt, the hardware is automatically cleared when entering the interrupt service program, and the software can also be cleared;
 0= External interrupt 1 did not produce an interrupt.
- Bit2 IT1: External interrupt 1 trigger mode control bit;
 1= Falling edge trigger;
 0= Low level triggering.
- Bit1 IE0: External interrupt 0 flag;
 1= External interrupt 0 generates an interrupt, the hardware is automatically cleared when entering the interrupt service program, and the software can also be cleared;
 0= External interrupt 0 did not produce an interrupt.
- Bit0 IT0: External interrupt 0 trigger mode control bit;
 1= Falling edge trigger;
 0= Low level triggering.

Flag bits that produce interrupts can be cleared by software, the same result as cleared by hardware. That is, an interrupt can be generated by software (it is not recommended to generate an interrupt by writing flag bits) or a pending interrupt can be canceled.

TF0, the TF1 flag bit can be cleared by writing 0 without enabling interrupt.

9.4 Timer0 Working Mode

9.4.1 T0 - Mode 0 (13-bit Timing/Counting Mode)

In this mode, timer 0 is a 13-bit register. When all the bits of the counter are flipped from 1 to 0, the timer 0 interrupt flag TF0 is set to 1. When TCON.4=1 and TMOD.3=0 or TCON.4=1, TMOD.3=1, T0G=1, the count input is enabled to timer 0. (Setting TMOD.3=1 allows timer 0 to be controlled by an external pin, T0G, for pulse width measurements). The 13-bit register consists of TH0 and TL0 low 5 bits. TL0 high 3 bits should be ignored. Timer0 Mode 0 block diagram is shown in the following figure:

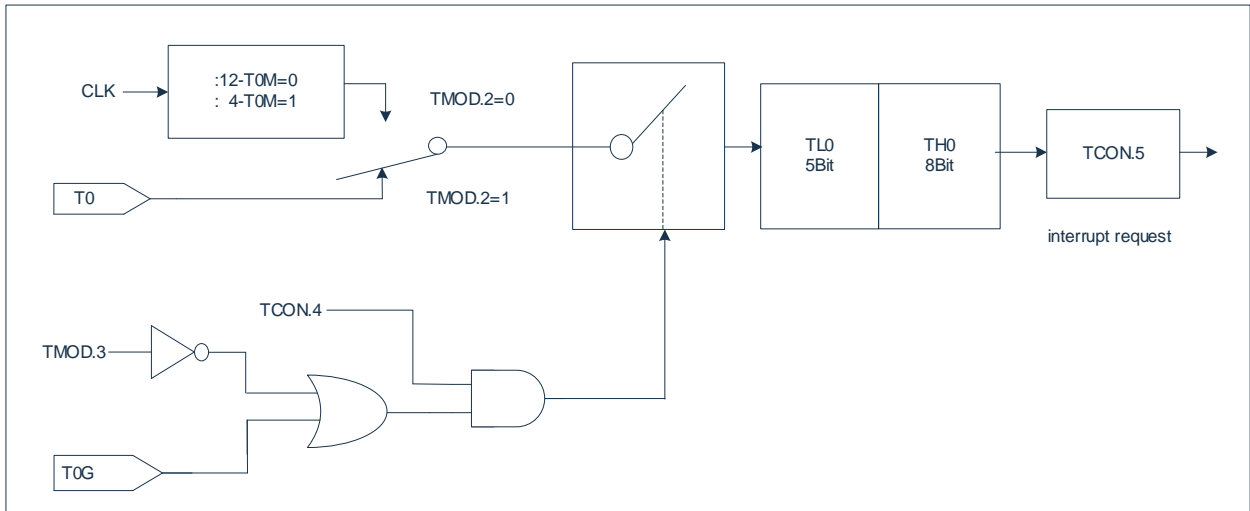

9.4.2 T0 - Mode 1 (16-bit Timing/Counting Mode)

Mode 1 is the same as mode 0, except that the timer 0 data register 16 bits are all running in mode 1. Timer0 mode 1 block diagram is shown in the following figure:

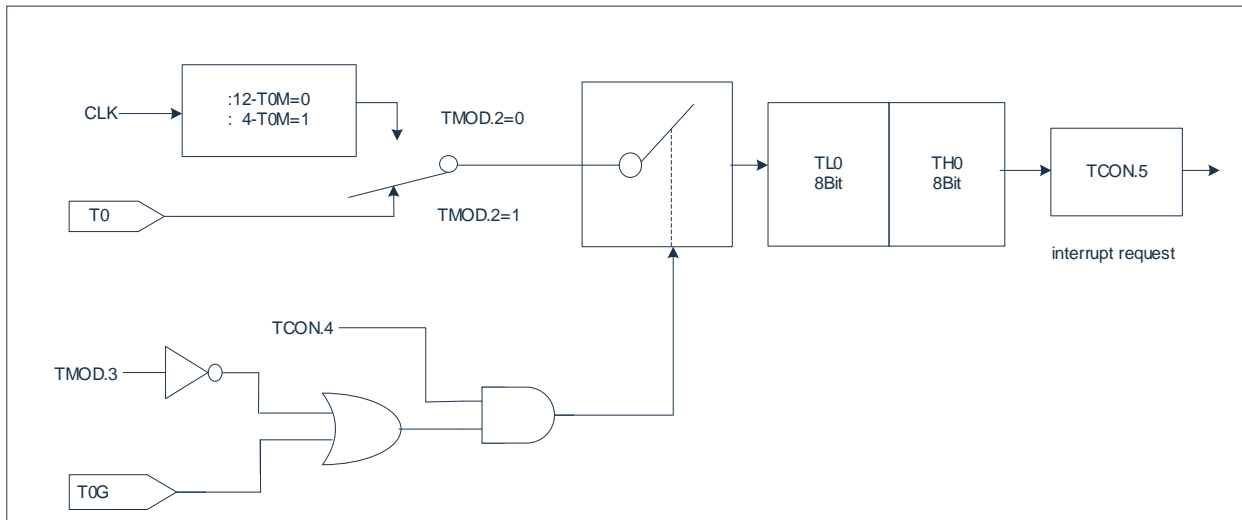

9.4.3 T0 - Mode 2 (8-bit Auto-reload Timing/Counting Mode)

The mode 2 timer register is an 8-bit counter (TL0) with auto reload mode, as shown in the figure below. The overflow from TL0 not only sets TF0 to 1, but also reloads the contents of TH0 from software to TL0. The value of TH0 remains unchanged during Reloading. Timer0 Mode 2 block diagram as below:

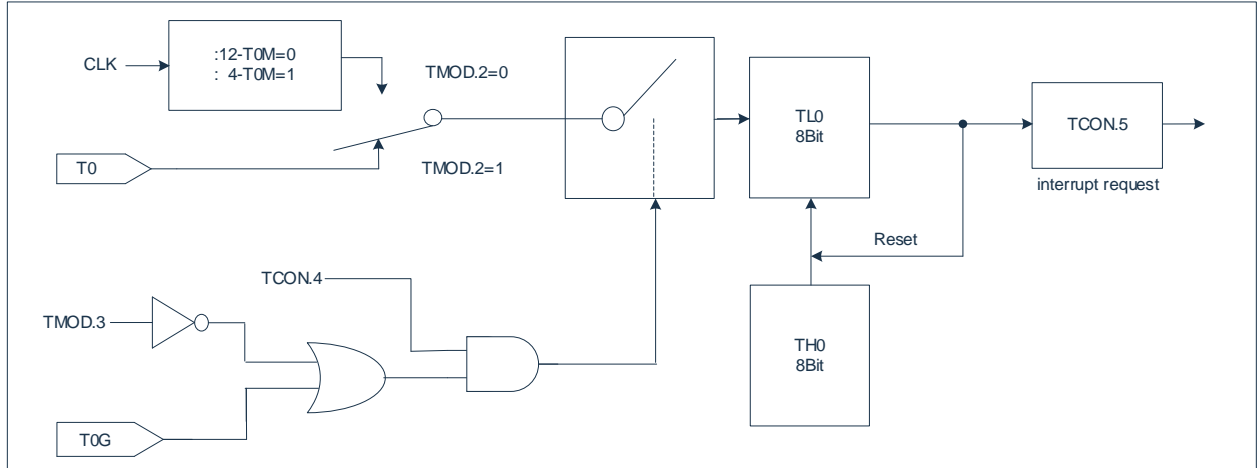

9.4.4 T0 - Mode 3 (Two Separate 8-bit Timers/Counters)

Timer 0 in mode 3 sets TL0 and TH0 to two independent counters. The logic of timer 0 mode 3 is shown in the following figure.

TL0 can operate as a timer or counter and use the control bits of timer 0: such as CT0, TR0, GATE0, and TF0.

TH0 can only operate as a timer, and uses the TR1 and TF1 flags of timer 1 and controls the interrupt of timer 1.

Mode 3 can be used when two 8-bit timers/counters are required. When timer 0 is in mode 3, timer 1 can turn it off by switching to its own mode 3, or it can still be used as a baud rate generator by the serial channel, or in any application that does not require an interrupt from timer 1. Timer0 Mode 3 block diagram is shown in the following figure:

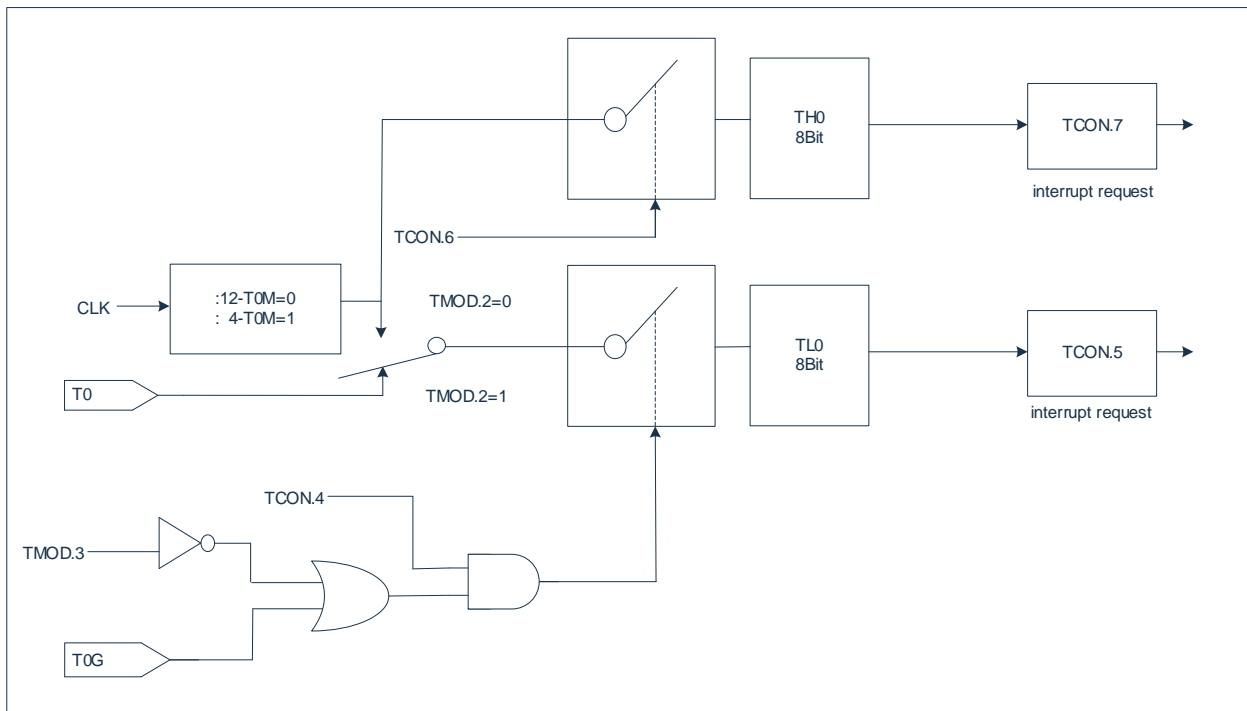

9.5.3 T1 - Mode 2 (8-bit Auto Reload Timing/Counting Mode)

The timer 1 register in mode 2 is an 8-bit counter (TL1) with auto-reload mode, as shown in the figure below. The overflow from TL1 not only makes TF1 1, but also reloads the contents of TH1 from software to TL1. The value of TH1 remains unchanged during Reloading. The Timer1 mode 2 block diagram is shown in the following figure:

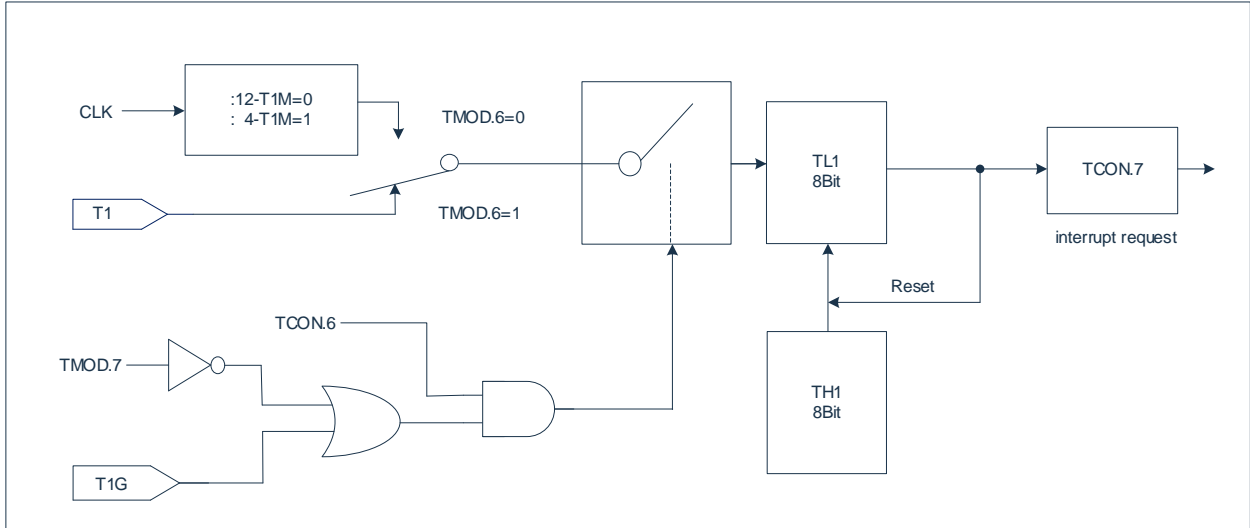

9.5.4 T1 - Mode 3 (Stop Count)

Timer 1 in mode 3 stops counting with the same effect as setting TR1=0.

10.2 Related Registers

10.2.1 Timer2 Control Register T2CON

0xC8	Bit7	Bit6	Bit5	Bit4	Bit3	Bit2	Bit1	Bit0
T2CON	T2PS	I3FR	CAPES	T2R1	T2R0	T2CM	T2I1	T2I0
R/W	R/W	R/W	R/W	R/W	R/W	R/W	R/W	R/W
Reset value	0	0	0	0	0	0	0	0

Bit7	T2PS: Timer2 clock prescaler selection bit; 1= Fsys/24; 0= Fsys/12.
Bit6	I3FR: Capture channel 0 input one-edge selection with comparison interrupt moment selection bit; Capture channel 0 mode: 1= Rising edge capture to RLDL/RLDH registers; 0= The falling edge is captured to the RLDL/RLDH register. Compare channel 0 modes: 1= TL2/TH2 and RLDL/RLDH never wait until the same moment to produce an interrupt; 0= TL2/TH2 and RLDL/RLDH are interrupted from the moment of equality to inequality;
Bit5	CAPES: Capture channels 1-3 input one-edge edge selection (in effect for capture channels 1-3). 0= The rising edge is captured to the CCL1/CCH1-CCL3/CCH3 registers; 1= The falling edge is captured to the CCL1/CCH1-CCL3/CCH3 registers.
Bit4~Bit3	T2R<1:0>: Timer2 Load mode select bit; 0x= Reloading is prohibited; 10= Loading mode 1: Automatically Reload when Timer2 overflows; 11= Loading mode 2: Reload on the falling edge of the T2EX pin.
Bit2	T2CM: Comparison mode selection; 1= Comparison mode 1; 0= Compare mode 0.
Bit1~Bit0	T2I<1:0>: Timer2 clock input select bit; 00= Timer2 stops; 01= Division of the system clock (selected by T2PS control crossover); 10= External pin T2 for event input (event count mode); 11= External pin T2 is the gating input (gating timing mode).

10.2.2 Timer2 Data Register Low bit TL2

0xCC	Bit7	Bit6	Bit5	Bit4	Bit3	Bit2	Bit1	Bit0
TL2	TL27	TL26	TL25	TL24	TL23	TL22	TL21	TL20
R/W	R/W	R/W	R/W	R/W	R/W	R/W	R/W	R/W
Reset value	0	0	0	0	0	0	0	0

Bit7~Bit0 TL2<7:0>: Timer 2 low bit data register (also as counter low bit).

10.2.3 Timer2 Data Register High TH2

0xCD	Bit7	Bit6	Bit5	Bit4	Bit3	Bit2	Bit1	Bit0
TH2	TH27	TH26	TH25	TH24	TH23	TH22	TH21	TH20
R/W	R/W	R/W	R/W	R/W	R/W	R/W	R/W	R/W
Reset value	0	0	0	0	0	0	0	0

Bit7~Bit0 TH2<7:0>: Timer 2 high-bit data register (also as counter low).

10.2.4 Timer2 Compare/Capture/Auto Reload Register Low Bit RLDL

0xCA	Bit7	Bit6	Bit5	Bit4	Bit3	Bit2	Bit1	Bit0
RLDL	RLDL7	RLDL6	RLDL5	RLDL4	RLDL3	RLDL2	RLDL1	RLDL0
R/W	R/W	R/W	R/W	R/W	R/W	R/W	R/W	R/W
Reset value	0	0	0	0	0	0	0	0

Bit7~Bit0 RLDL<7:0>: Timer 2 compare/capture/auto reload register low.

10.2.5 Timer2 Compare/Capture/Auto Reload Register High Bit RLDH

0xCB	Bit7	Bit6	Bit5	Bit4	Bit3	Bit2	Bit1	Bit0
RLDH	RLDH7	RLDH6	RLDH5	RLDH4	RLDH3	RLDH2	RLDH1	RLDH0
R/W	R/W	R/W	R/W	R/W	R/W	R/W	R/W	R/W
Reset value	0	0	0	0	0	0	0	0

Bit7~Bit0 RLDH<7:0>: Timer 2 compare/capture/auto reload register high bits.

10.2.6 Timer2 Compares/Captures Channel 1 Register Low Bit CCL1

0xC2	Bit7	Bit6	Bit5	Bit4	Bit3	Bit2	Bit1	Bit0
CCL1	CCL17	CCL16	CCL15	CCL14	CCL13	CCL12	CCL11	CCL10
R/W	R/W	R/W	R/W	R/W	R/W	R/W	R/W	R/W
Reset value	0	0	0	0	0	0	0	0

Bit7~Bit0 CCL1<7:0>: Timer 2 compares/captures channel 1 register low.

10.2.7 Timer2 Compares/Captures Channel 1 Register High Bit CCH1

0xC3	Bit7	Bit6	Bit5	Bit4	Bit3	Bit2	Bit1	Bit0
CCH1	CCH17	CCH16	CCH15	CCH14	CCH13	CCH12	CCH11	CCH10
R/W	R/W	R/W	R/W	R/W	R/W	R/W	R/W	R/W
Reset value	0	0	0	0	0	0	0	0

Bit7~Bit0 CCH1<7:0>: Timer 2 compares/captures channel 1 register high bits.

10.2.8 Timer2 Compares/Captures Channel 2 Register Low-bit CCL2

0xC4	Bit7	Bit6	Bit5	Bit4	Bit3	Bit2	Bit1	Bit0
CCL2	CCL27	CCL26	CCL25	CCL24	CCL23	CCL22	CCL21	CCL20
R/W	R/W	R/W	R/W	R/W	R/W	R/W	R/W	R/W
Reset value	0	0	0	0	0	0	0	0

Bit7~Bit0 CCL2<7:0>: Timer 2 compares/captures channel 2 registers low.

10.2.9 Timer2 Compares/Captures Channel 2 Register High-bit CCH2

0xC5	Bit7	Bit6	Bit5	Bit4	Bit3	Bit2	Bit1	Bit0
CCH2	CCH27	CCH26	CCH25	CCH24	CCH23	CCH22	CCH21	CCH20
R/W	R/W	R/W	R/W	R/W	R/W	R/W	R/W	R/W
Reset value	0	0	0	0	0	0	0	0

Bit7~Bit0 CCH2<7:0>: Timer 2 compares/captures channel 2 register bits.

10.2.10 Timer2 Compares/Captures Channel 3 Register Low-bit CCL3

0xC6	Bit7	Bit6	Bit5	Bit4	Bit3	Bit2	Bit1	Bit0
CCL3	CCL37	CCL36	CCL35	CCL34	CCL33	CCL32	CCL31	CCL30
R/W	R/W	R/W	R/W	R/W	R/W	R/W	R/W	R/W
Reset value	0	0	0	0	0	0	0	0

Bit7~Bit0 CCL3<7:0>: Timer 2 compares/captures channel 3 registers low.

10.2.11 Timer2 Compares/Captures Channel 3 Register High-bit CCH3

0xC7	Bit7	Bit6	Bit5	Bit4	Bit3	Bit2	Bit1	Bit0
CCH3	CCH37	CCH36	CCH35	CCH34	CCH33	CCH32	CCH31	CCH30
R/W	R/W	R/W	R/W	R/W	R/W	R/W	R/W	R/W
Reset value	0	0	0	0	0	0	0	0

Bit7~Bit0 CCH3<7:0>: Timer 2 compares/captures channel 3 register high bits.

10.2.12 Timer2 Compares the Capture Control Register CCEN

0xCE	Bit7	Bit6	Bit5	Bit4	Bit3	Bit2	Bit1	Bit0
CCEN	CMH3	CML3	CMH2	CML2	CMH1	CML1	CMH0	CML0
R/W	R/W	R/W	R/W	R/W	R/W	R/W	R/W	R/W
Reset value	0	0	0	0	0	0	0	0

- Bit7~Bit6 CMH3-CML3: Capture/Compare Mode Control Bits;
 00= Capture/Compare Prohibited;
 01= The capture operation is triggered on the rising or falling edge of channel 3 (CAPES selection);
 10= Comparison mode enable;
 11= The capture operation is triggered when writing CCL3 or the double edge of channel 3.
- Bit5~Bit4 CMH2-CML2: Capture/Compare Mode Control Bits;
 00= Capture/Compare Prohibited;
 01= The capture operation is triggered on the rising or falling edge of channel 2 (CAPES selection);
 10= Comparison mode enable;
 11= The capture operation is triggered when writing CCL2 or the double edge of channel 2.
- Bit3~Bit2 CMH1-CML1: Capture/Compare Mode Control Bits;
 00= Capture/Compare Prohibited;
 01= The capture operation is triggered on the rising or falling edge of channel 1 (CAPES selection);
 10= Comparison mode enable;
 11= The capture operation is triggered when writing CCL1 or the double edge of channel 1.
- Bit1~Bit0 CMH0-CML0: Capture/Compare Mode Control Bits;
 00= Capture/Compare Prohibited;
 01= The capture operation is triggered on the rising or falling edge of channel 0 (I3FR selection);
 10= Comparison mode enable;
 11= The capture operation is triggered when writing the RLDL or the double edge of channel 0.

10.3 Timer2 Interrupts

Timer 2 can be enabled or disabled by register IE, and high/low priority can also be set via IP registers. Timer2 has 4 interrupt types:

- ◆ A timed overflow interrupt.
- ◆ The external pin T2EX drops along the interrupt.
- ◆ Compare interrupts.
- ◆ Capture interrupts.

To set the Timer2 interrupt, configure the global interrupt enable bit (EA=1), the Timer2 global interrupt enable bit (ET2=1), and the corresponding interrupt type enable bit (T2IE) for Timer2. The four types of interrupts in Timer2 all share an interrupt vector, and after entering the interrupt service program, you need to determine the relevant flag bits to determine which type of interrupt is generated.

10.3.1 Interrupt Correlation Registers

10.3.1.1 Interrupt Mask Register IE

0xA8	Bit7	Bit6	Bit5	Bit4	Bit3	Bit2	Bit1	Bit0
IE	SHE	ES1	ET2	ES0	ET1	EX1	ET0	EX0
R/W	R/W	R/W	R/W	R/W	R/W	R/W	R/W	R/W
Reset value	0	0	0	0	0	0	0	0

Bit7	SHE: Global interrupt enable bits; 1= Enable all unblocked interrupts; 0= Disable all interrupts.
Bit6	ES1: UART1 interrupt enable bit; 1= Enable UART1 interrupt; 0= Disable UART1 Interrupt.
Bit5	ET2: TIMER2 Global interrupt Enable bits; 1= Enable all interrupts of TIMER2; 0= All interrupts of TIMER2 are disabled.
Bit4	ES0: UART0 interrupt enable bit; 1= Enable UART0 interrupts; 0= Disable UART0 Interrupt.
Bit3	ET1: TIMER1 interrupt enable bit; 1= Enable TIMER1 interrupts; 0= Prohibited TIMER1 Interrupt.
Bit2	EX1: External interrupt 1 interrupt enable bits; 1= Enable external interrupt 1 interrupt; 0= Disable external interrupt 1 interrupt.
Bit1	ET0: TIMER0 interrupt enable bits; 1= Enable TIMER0 interrupts; 0= Prohibited TIMER0 Interrupts.
Bit0	EX0: External interrupt 0 interrupt enable bit; 1= Enable external interrupt 0 interrupts; 0= Disable external interrupt 0 interrupt.

10.3.1.2 Timer2 Interrupt Mask Register T2IE

0xCF	Bit7	Bit6	Bit5	Bit4	Bit3	Bit2	Bit1	Bit0
T2IE	T2OVIE	T2EXIE	--	--	T2C3IE	T2C2IE	T2C1IE	T2C0IE
R/W	R/W	R/W	R/W	R/W	R/W	R/W	R/W	R/W
Reset value	0	0	0	0	0	0	0	0

- Bit7 T2OVIE: Timer2 overflow interrupt enable bits;
 1= Interrupts are Enabled;
 0= Disable Interrupt.
- Bit6 T2EXIE: Timer2 external loading interrupt enable bits;
 1= Interrupts are Enabled;
 0= Disable Interrupt.
- Bit5~Bit4 -- Reserved, must be 0.
- Bit3 T2C3IE: Timer2 compares channel 3 interrupt allowable bits;
 1= Interrupts are Enabled;
 0= Disable Interrupt.
- Bit2 T2C2IE: Timer2 compares channel 2 interrupt enable bits;
 1= Interrupts are Enabled;
 0= Disable Interrupt.
- Bit1 T2C1IE: Timer2 compares channel 1 interrupt enable bits;
 1= Interrupts are Enabled;
 0= Disable Interrupt.
- Bit0 T2C0IE: Timer2 compares channel 0 interrupt Enabled bits;
 1= Interrupts are Enabled;
 0= Disable Interrupt.

If you want to enable the interrupt of Timer2, you also need to enable the global interrupt enable bit OF TIME2=1 (IE.5=1).

10.3.1.3 Interrupt Priority Control Register IP

0xB8	Bit7	Bit6	Bit5	Bit4	Bit3	Bit2	Bit1	Bit0
IP	--	PS1	PT2	PS0	PT1	PX1	PT0	PX0
R/W	R/W	R/W	R/W	R/W	R/W	R/W	R/W	R/W
Reset value	0	0	0	0	0	0	0	0

- Bit7 -- Reserved, must be 0.
- Bit6 PS1: UART1 interrupt priority control bit;
 1= Set to High-level Interrupt;
 0= Set to low-level interrupt.
- Bit5 PT2: TIMER2 interrupt priority control bit;
 1= Set to High-level Interrupt;
 0= Set to low-level interrupt.
- Bit4 PS0: UART0 interrupt priority control bit;
 1= Set to High-level Interrupt;
 0= Set to low-level interrupt.
- Bit3 PT1: TIMER1 interrupt priority control bit;
 1= Set to High-level Interrupt;
 0= Set to low-level interrupt.
- Bit2 PX1: External interrupt 1 interrupt priority control bit;
 1= Set to High-level Interrupt;

- 0= Set to low-level interrupt.
- Bit1 PT0: TIMER0 interrupt priority control bit;
1= Set to High-level Interrupt;
0= Set to low-level interrupt.
- Bit0 PX0: External interrupt 0 interrupt priority control bit;
1= Set to High-level Interrupt;
0= Set to low-level interrupt.

10.3.1.4 Timer2 Interrupt Flag Bit Register T2IF

0xC9	Bit7	Bit6	Bit5	Bit4	Bit3	Bit2	Bit1	Bit0
T2IF	TF2	T2EXIF	--	--	T2C3IF	T2C2IF	T2C1IF	T2C0IF
R/W	R/W	R/W	R/W	R/W	R/W	R/W	R/W	R/W
Reset value	0	0	0	0	0	0	0	0

- Bit7 TF2: Timer2 counter overflow interrupt flag bit;
1= Timer2 counter overflow, software zeroing is required;
0= The Timer2 counter has no overflow.
- Bit6 T2EXIF: Timer2 externally loaded flag bits;
1= The T2EX port of Timer2 generates a falling edge, which requires software clearance;
0= --
- Bit5~Bit4 -- Reserved, must be 0.
- Bit3 T2C3IF: Timer2 Compare/Capture Channel 3 Flag Bits;
1= Timer2 Compare channel 3 {CCH3:CCL3}={TH2:TL2} or capture channel 3 produces a capture operation that requires software zeroing.
0= --
- Bit2 T2C2IF: Timer2 Compare/Capture Channel 2 Flag Bits;
1= Timer2 Compare channel 2 {CCH2:CCL2}={TH2:TL2} or capture channel 2 to produce a capture operation that requires software zeroing.
0= --
- Bit1 T2C1IF: Timer2 Compare/Capture Channel 1 Flag Bits;
1= Timer2 Compare channel 1 {CCH1:CCL1}={TH2:TL2} or capture channel 1 to produce a capture operation that requires software zeroing.
0= --
- Bit0 T2C0IF: Timer2 Compare/Capture Channel 0 Flag Bits;
1= Timer2 Compare channel 0 {RLDH:RLDL}={TH2:TL2} or capture channel 0 produces a capture operation that requires software zeroing.
0= --

10.3.2 Timer Interrupts

The timer interrupt enable bit is set by register T2IE[7], and the interrupt flag bit is viewed by register T2IF[7]. When the Timer2 timer overflows, the timer overflow interrupt flag bit TF2 will be set to 1.

10.3.3 Externally Triggered Interrupts

The external pin T2EX falling edge trigger interrupt enable bit is set by register T2IE[6], and the interrupt flag bit is viewed by register T2IF[6]. When the T2EX pin drops the edge, the external load interrupt flag bit T2EXIF will be placed at 1.

10.3.4 Compare Interrupts

All four comparison channels support comparison interrupts. The comparison interrupt enable bit is set by register T2IE[3:0], and the interrupt flag bit is viewed by register T2IF[3:0].

Comparing channel 0 can choose to compare the moment when the interrupt occurred, and if an interrupt is generated, the interrupt flag T2C0IF of the comparison channel 0 is set to 1.

When I3FR = 0, TL2/TH2 and RLDL/RLDH never wait until the same moment to produce an interrupt;

When I3FR = 1, TL2/TH2 and RLDL/RLDH are interrupted from the moment of equality to inequality;

Comparing channels 1 to 3 can not choose the interrupt generation time, fixed to TL2/TH2 and CCxL/CCxH never wait until the same time to produce an interrupt. If an interrupt is generated, the corresponding comparison channel interrupt flag T2CxIF is set to 1.

10.3.5 Capture Interrupts

All four capture channels support external capture interrupts. The capture interrupt enable bit is set by register T2IE[3:0], and the interrupt flag bit is viewed by register T2IF[3:0]. When a capture operation is generated, the interrupt flag T2CxIF of the corresponding capture channel is set to 1.

Note Write capture does not produce interrupts.

10.4 Timer2 Feature Description

Timer 2 is a 16-bit up counting timer with a clock source from the system clock. Timer2 can be configured with the following functional modes:

- ◆ Timing mode.
- ◆ Reload mode.
- ◆ Gating timing mode.
- ◆ Event counting mode.
- ◆ Compare mode.
- ◆ Capture mode.

Different modes of timer 2 can be set for generation and event capture of various digital signals, such as pulse generation, pulse width modulation, pulse width measurement, etc.

10.4.1 Timing Mode

When used as a timer function, the clock source comes from the system clock. The prescaler provides 1/12 or 1/24 system frequency selection, and the value of the prescaler is selected by the T2PS bit of register T2CON. Thus, the 16-bit timer register (consisting of TH2 and TL2) is incremented every 12 clock cycles or every 24 clock cycles.

10.4.2 Reload Mode

The reload mode of timer 2 is selected by the T2R0 and T2R1 bits of register T2CON, as shown in the reload block diagram below.

In load mode 1: When the Timer2 counter is flipped from all 1 to 0 (counter overflow), not only the interrupt flag bit TF2 is set to 1, but the Timer2 register automatically loads the 16-bit value from the RLDL/RLDH register, thus covering the 0x0000 of the count value, and the required RLDL/RLDH value can be preset by the software.

In load mode 2: The 16-bit reload operation from the RLDL/RLDH register is triggered by the falling edge of the corresponding T2EX input pin. When the falling edge of T2EX is detected, the external loading interrupt flag bit T2EXIF is set to 1, while Timer2 automatically loads the 16-bit value of the RLDL/RLDH register as the initial value of the count.

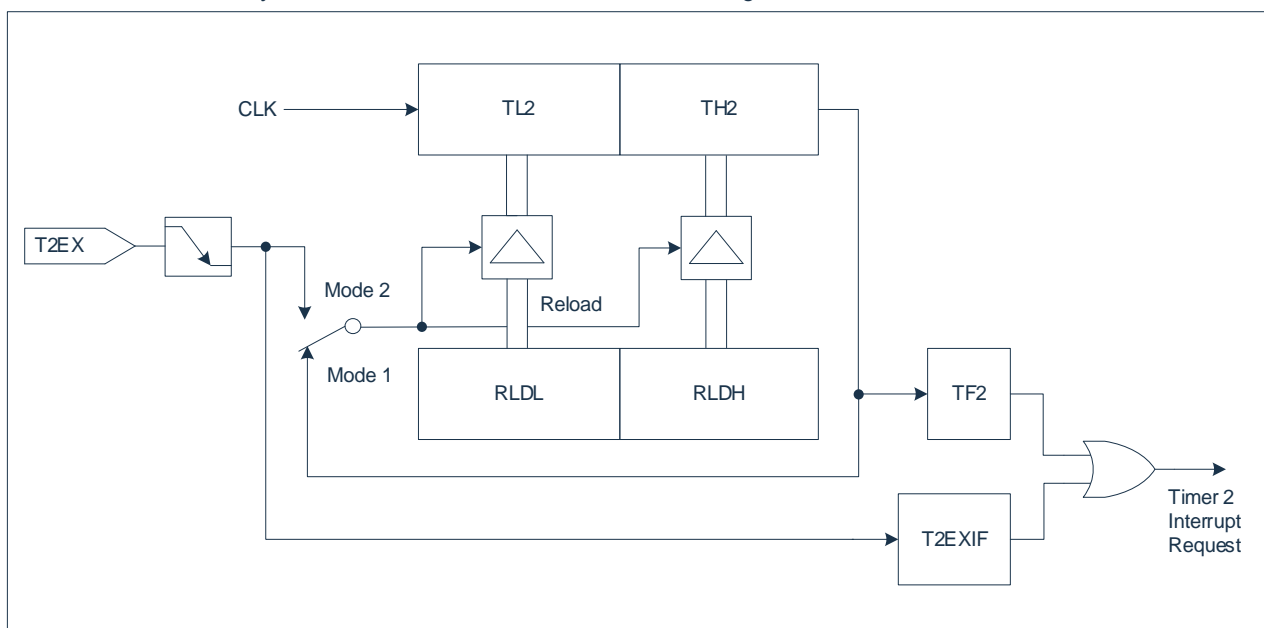

10.4.3 Gated Timing Mode

When Timer2 is used as a gated timer function, an external input pin, T2, serves as the gated input to timer 2. If the T2 pin is high, the internal clock input is gated to the timer. A low T2 pin terminates the counting. This function is often used to measure pulse width.

10.4.4 Event Counting Mode

When Timer2 is used as an event counting function, the timer counter adds 1 to the falling edge of the external input pin T2. The external input signal is sampled at each system clock cycle, and the count increases when the sampling input shows a high level for one cycle and a low level for the next. When a change from high to low on the T2 pin is detected in the following cycle, the new count value is updated to the timer data register.

10.4.5 Compare Mode

The comparison function consists of two modes: comparison mode 0 and comparison mode 1, selected by the T2CM bit in the special function register T2CON. These two comparison modes generate periodic signals and change the duty cycle control mode, and are often used for pulse width modulation (PWM) and control applications where continuous square waves need to be generated, covering a wide range of applications.

The output channels of the comparison function are CC0, CC1, CC2, CC3. Corresponding to the 16-bit comparison register {RLDH,RLDL},{CCH1,CCL1},{CCH2,CCL2},{CCH3,CCL3} and the data register {TH2,TL2} output signal.

The 16-bit stored value stored in the comparison register is compared to the count value of the timer, and if the count value in the data register matches the stored value, a jump in the output signal is generated on the corresponding port pin and an interrupt flag bit is generated.

10.4.5.1 Compare Mode 0

In mode 0, when the timer's count value and the comparison register are equal, the comparison output signal changes from low to high. When the timer count value overflows, the comparison output signal goes low. The comparison output channel is directly controlled by two events: the timer overflow and the comparison operation. The block diagram of comparison mode 0 is shown in the following figure:

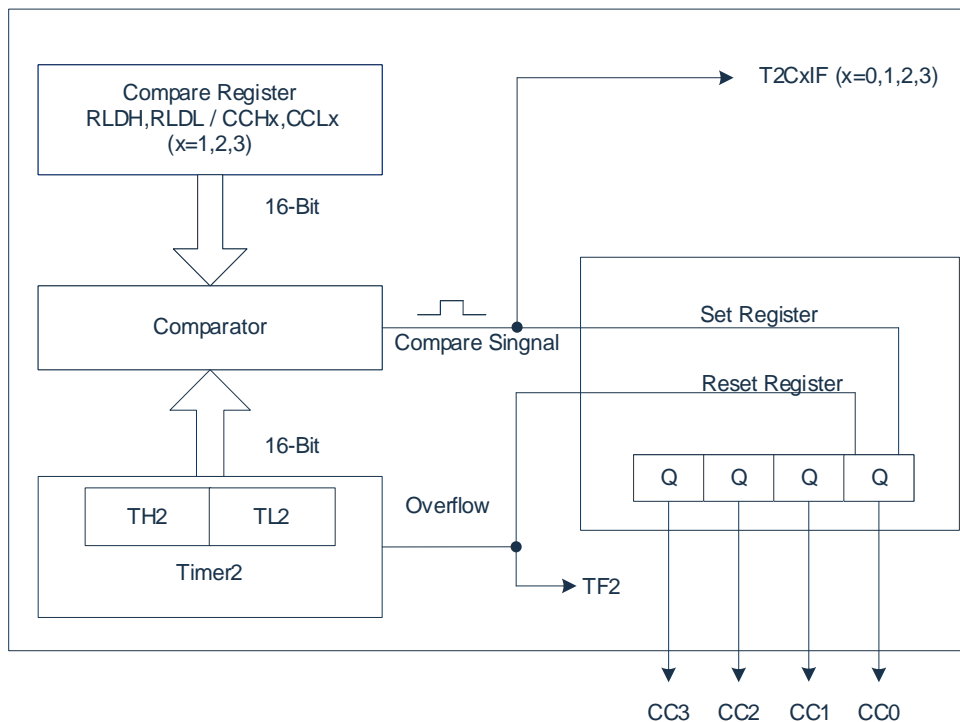

The output block diagram of comparison mode 0 is shown in the following figure:

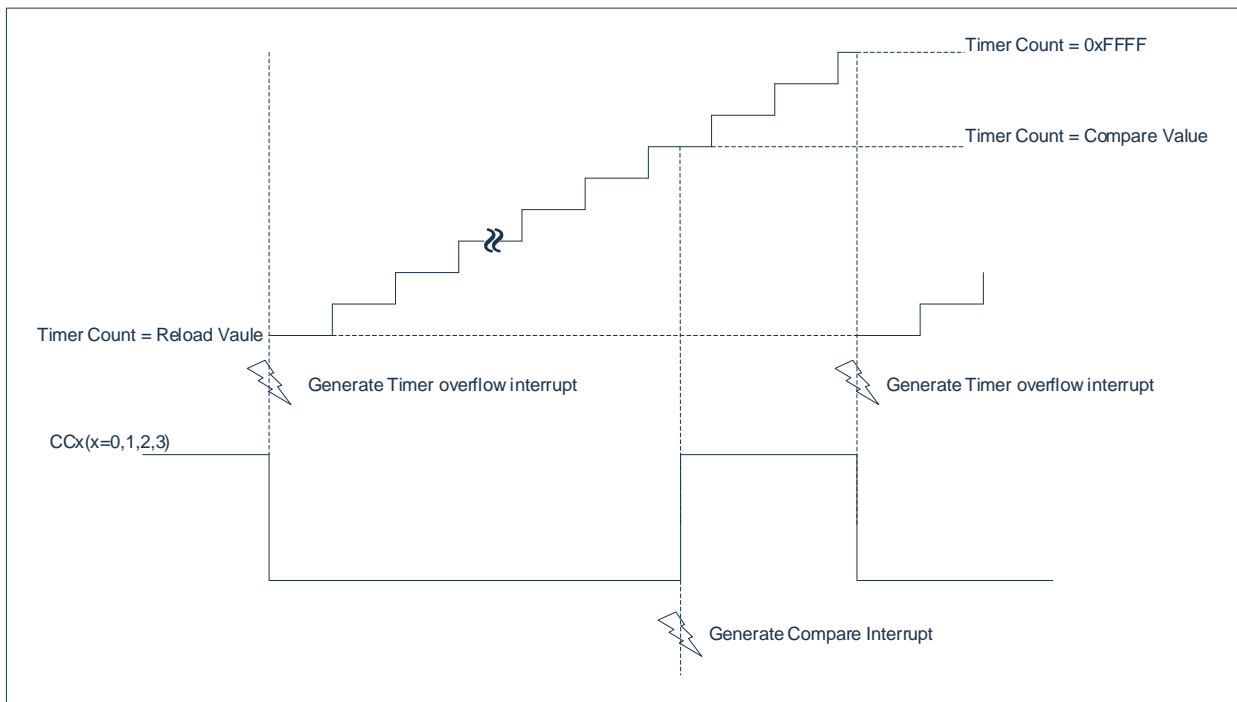

10.4.5.2 Comparison Mode 1

In comparison mode 1, it is typically used where the output signal is independent of a constant signal cycle, where the software adaptively determines the output signal transition.

If mode 1 is enabled, the software writes to the corresponding output register of the CCx port, and the new value does not appear on the output pin until the next comparison match occurs. When the timer 2 counter matches the stored comparison value, the user can choose whether the output signal changes the new value or keeps its old value in one of two ways. The block diagram of Comparison Mode 1 is shown in the following figure:

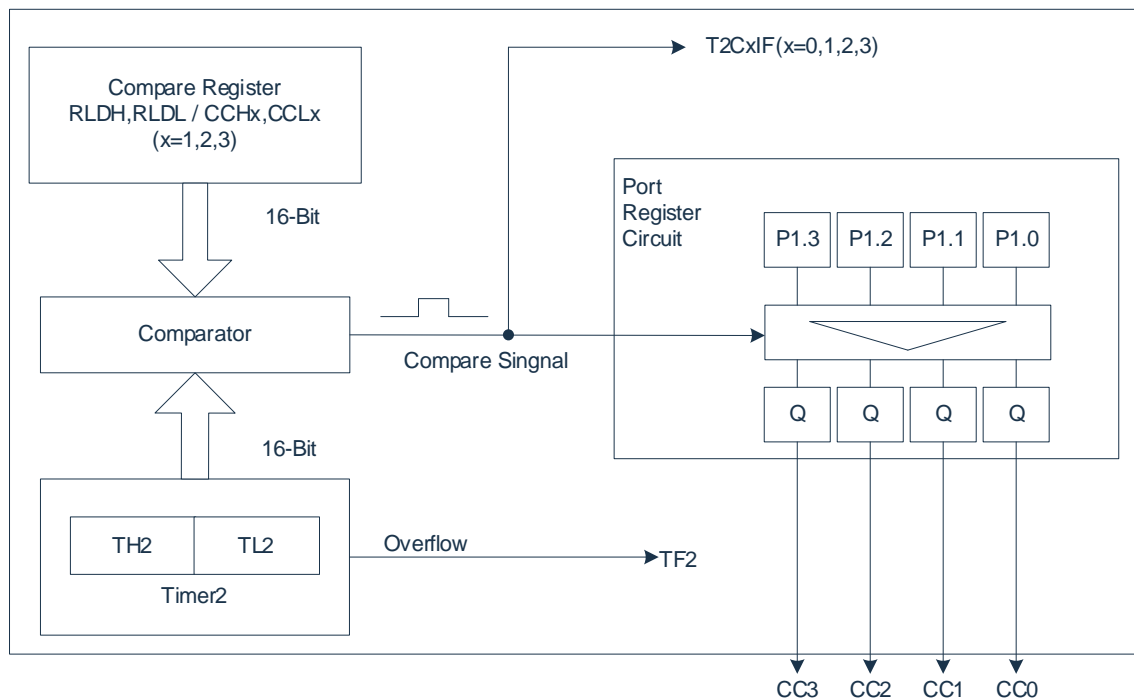

10.4.6 Capture Mode

Each of the four 16-bit registers {RLDH,RLDL}, {CCH1,CCL1}, {CCH2,CCL2}, {CCH3,CCL3} can be used to latch the current 16-bit value of {TH2,TL2}. This feature provides two different capture modes.

In mode 0, an external event can latch the contents of timer 2 into the capture register.

In mode 1, the capture operation occurs when a low-bit byte (RLDL/CCL1/CCL2/CCL3) is written to the 16-bit capture register. This mode allows the software to read the contents of {TH2,TL2} at runtime.

Capture channels 0 to 3 select the capture input pins CAP0 to CAP3 as the input source signal.

10.4.6.1 Capture Mode 0

In capture mode 0, positive, negative, or positive and negative transactions on capture channels 0 to 3 (CAP0 to CAP3) will produce capture events. When a capture event occurs, the timer's count value lock is stored in the corresponding capture register.

Whether a positive transaction triggers capture operation or a negative transaction triggers capture operation on capture channel 0 depends on the I3FR bit of T2CON. I3FR=0, negative transaction trigger capture; I3FR=1, positive transaction trigger capture.

Whether a positive transaction trigger capture operation or a negative transaction trigger capture operation on capture channels 1 to 3 depends on the CAPES bit of the T2CON. CAPES=0, positive transaction trigger capture; CAPES= 1, negative transaction trigger capture. The transition mode for the selection of capture channels 1 to 3 is the same

Capture channels 0 to 3 support double- transactions capture operations at the same time. Select the corresponding operating mode control bit of the CCEN register to 11, and the channel supports double- transaction capture operation. It should be noted that this mode of operation also supports capture mode 1, that is, the write operation can produce a capture action.

In capture mode 0, external capture events from capture channel 0 to 3 can produce interrupt.

The block diagram of Capture Mode 0 is shown in the following figure:

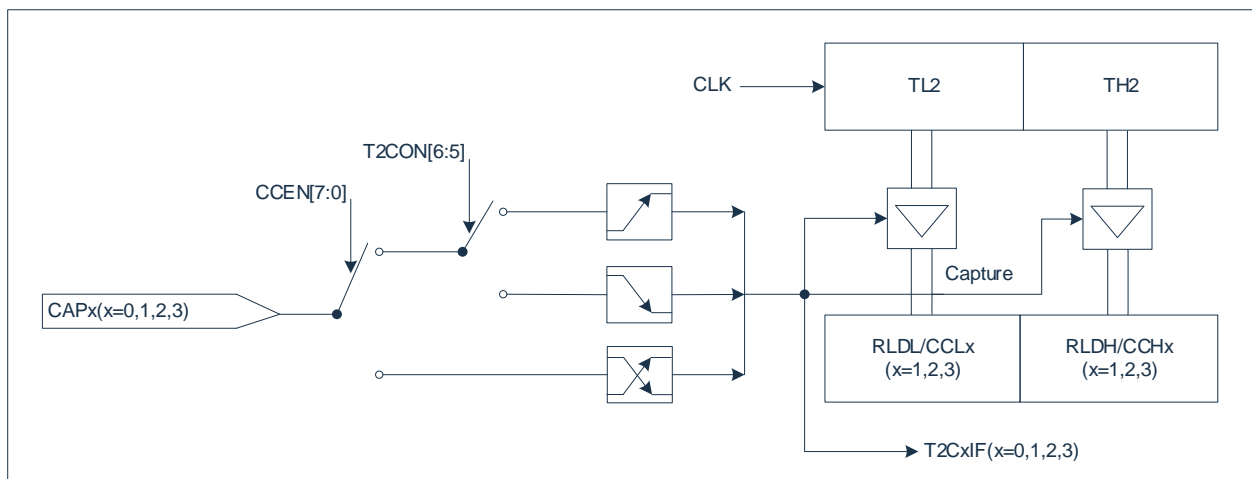

10.4.6.2 Capture Mode 1

In capture mode 1, the capture operation event is the execution of a write byte instruction to the capture register. A write register signal, such as a write RLDL, initiates a capture operation, and the value written is independent of this function. After the write instruction is executed, the contents of timer 2 are latched into the corresponding capture register.

In capture mode 1, capture events for capture channels 0 to 3 do not produce interrupt request flags.

The block diagram of Capture Mode 1 is shown in the following figure:

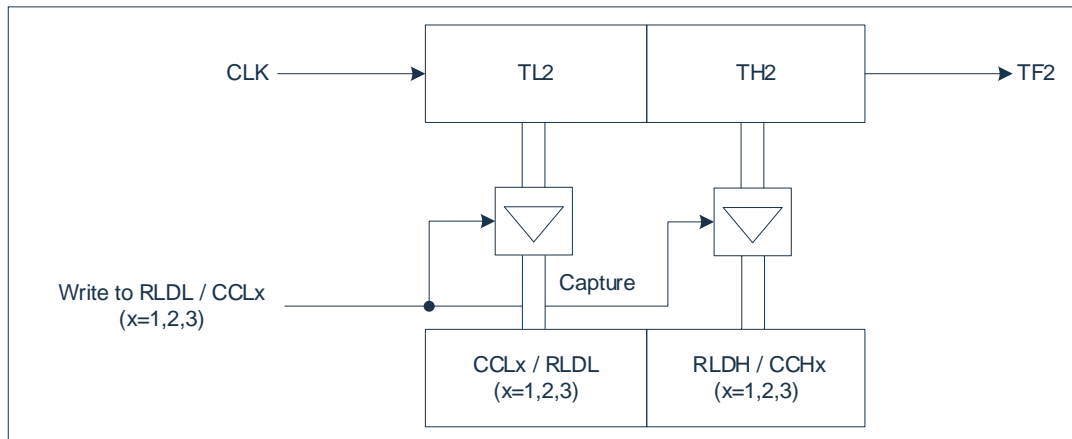

11. Timer 3/4 (Timer3/4)

Timer 3/4 is similar to timer 0/1 in that it is two 16-bit timers. Timer 3 has four modes of operation and Timer 4 has three modes of operation. In contrast to Timer0/1, Timer3/4 only provides timer operations.

With the timer activated, the value of the register is incremented every 12 or 4 system cycles.

11.1 Overview

Timer 3 and timer 4 consist of two 8-bit registers {TH3,TL3} and {TH4,TL4}. Timers 3,4 operate in four identical modes. The Timer3 and Timer4 modes are described below:

mode	M1	M0	Feature description
0	0	0	THx [7:0], TLx [4:0] make up a 13-bit timer
1	0	1	THx [7:0], TLx [7:0] make up a 16-bit timer
2	1	0	TLx [7:0] consists of an 8-bit auto-reload timer that is reinstalled from THx
3	1	1	TL3, TH3 are two 8-bit timers, and Timer4 stop counting

11.2 Related Registers

11.2.1 Timer3/4 Control Register T34MOD

0xD2	Bit7	Bit6	Bit5	Bit4	Bit3	Bit2	Bit1	Bit0
T34MOD	TR4	T4M	T4M1	T4M0	TR3	T3M	T3M1	T3M0
R/W	R/W	R/W	R/W	R/W	R/W	R/W	R/W	R/W
Reset value	0	0	0	0	0	0	0	0

Bit7	TR4: Timer4 operational control bit; 1= Timer4 starts; 0= Timer4 is off.
Bit6	T4M: Timer 4 clock select bits; 1= Fsys/4; 0= Fsys/12.
Bit5~Bit4	T4M<1:0>: Timer 4 mode select bit; 00= Mode 0, 13-bit timer; 01= Mode 1, 16-bit timer; 10= Mode 2, 8-bit automatic reload timer; 11= Mode 3, Stop Count.
Bit3	TR3: Timer3 operational control bit; 1= Timer3 starts; 0= Timer3 is off.
Bit2	T3M: Timer 3 clock select bits; 1= Fsys/4; 0= Fsys/12.
Bit1~Bit0	T3M<1:0>: Timer 3 mode select bit; 00= Mode 0, 13-bit timer; 01= Mode 1, 16-bit timer; 10= Mode 2, 8-bit automatic reload timer; 11= Mode 3, two independent 8-bit timers.

11.2.2 Timer3 Data Register Low Bit TL3

0xDA	Bit7	Bit6	Bit5	Bit4	Bit3	Bit2	Bit1	Bit0
TL3	TL37	TL36	TL35	TL34	TL33	TL32	TL31	TL30
R/W	R/W	R/W	R/W	R/W	R/W	R/W	R/W	R/W
Reset value	0	0	0	0	0	0	0	0

Bit7~Bit0 TL3<7:0>: Timer 3 low bit data register (while acting as timer low bit).

11.2.3 Timer3 Data Register High Bit TH3

0xDB	Bit7	Bit6	Bit5	Bit4	Bit3	Bit2	Bit1	Bit0
TH3	TH37	TH36	TH35	TH34	TH33	TH32	TH31	TH30
R/W	R/W	R/W	R/W	R/W	R/W	R/W	R/W	R/W
Reset value	0	0	0	0	0	0	0	0

Bit7~Bit0 TH3<7:0>: Timer 3 high bit data register (also as timer high bit).

11.2.4 Timer4 Data Register Low Bit TL4

0xE2	Bit7	Bit6	Bit5	Bit4	Bit3	Bit2	Bit1	Bit0
TL4	TL47	TL46	TL45	TL44	TL43	TL42	TL41	TL40
R/W	R/W	R/W	R/W	R/W	R/W	R/W	R/W	R/W
Reset value	0	0	0	0	0	0	0	0

Bit7~Bit0 TL4<7:0>: Timer 4 low bit data register (also as timer low bit).

11.2.5 Timer4 Data Register High Bit TH4

0xE3	Bit7	Bit6	Bit5	Bit4	Bit3	Bit2	Bit1	Bit0
TH4	TH47	TH46	TH45	TH44	TH43	TH42	TH41	TH40
R/W	R/W	R/W	R/W	R/W	R/W	R/W	R/W	R/W
Reset value	0	0	0	0	0	0	0	0

Bit7~Bit0 TH4<7:0>: Timer 4 high bit data register (also as timer high bit).

11.3 Timer3/4 Interrupt

Timer 3/4 can enable or disable interrupts via the EIE2 register, and high/low priority can also be set via the EIP2 register, where the relevant bits are described as following:

11.3.1 Interrupt Mask Register EIE2

0xAA	Bit7	Bit6	Bit5	Bit4	Bit3	Bit2	Bit1	Bit0
EIE2	SPIIE	I2CIE	WDTIE	ADCIE	PWMIE	--	ET4	ET3
R/W	R/W	R/W	R/W	R/W	R/W	R/W	R/W	R/W
Reset value	0	0	0	0	0	0	0	0

Bit7	SPIIE: SPI interrupt enable bit; 1= Enable SPI interrupts; 0= Prohibited SPI Interrupt.
Bit6	I2CIE I2C interrupt enable bit; 1= Enable I2C interrupts; 0= Disable I ² C Interrupt.
Bit5	WDTIE: WDT interrupt enable bit; 1= Enable WDT overflow interrupts; 0= Disable WDT overflow interrupts.
Bit4	ADCIE: ADC interrupt enable bit; 1= Enable ADC interrupts; 0= Prohibited ADC interrupts.
Bit3	PWMIE: PWM global interrupt enable bit; 1= Enable all PWM interrupts; 0= Disable all PWM interrupts.
Bit2	-- Reserved, must be 0.
Bit1	ET4: Timer4 interrupt enable bit; 1= Enable Timer4 interrupts; 0= Disable Timer4 Interrupt.
Bit0	ET3: Timer3 interrupt enable bit; 1= Enable Timer3 interrupts; 0= Disable Timer3 Interrupt.

11.3.2 Interrupt Priority Control Register EIP2

0xBA	Bit7	Bit6	Bit5	Bit4	Bit3	Bit2	Bit1	Bit0
EIP2	PSPI	PI2C	PWDT	PADC	PPWM	PLED	PT4	PT3
R/W	R/W	R/W	R/W	R/W	R/W	R/W	R/W	R/W
Reset value	0	0	0	0	0	0	0	0

- Bit7 PSPI: SPI interrupt priority control bit;
 1= Set to High-level Interrupt;
 0= Set to low-level interrupt.
- Bit6 PI2C: I2C interrupt priority control bit;
 1= Set to High-level Interrupt;
 0= Set to low-level interrupt.
- Bit5 PWDT: WDT interrupt priority control bit;
 1= Set to High-level Interrupt;
 0= Set to low-level interrupt.
- Bit4 PADC: ADC interrupt priority control bit;
 1= Set to High-level Interrupt;
 0= Set to low-level interrupt.
- Bit3 PPWM: PWM interrupt priority control bit
 1= Set to High-level Interrupt;
 0= Set to low-level interrupt.
- Bit2 PLED: LED dot matrix scan interrupt priority control bit
 1= Set to High-level Interrupt;
 0= Set to low-level interrupt.
- Bit1 PT4: TIMER4 interrupt priority control bit;
 1= Set to High-level Interrupt;
 0= Set to low-level interrupt.
- Bit0 PT3: TIMER3 interrupt priority control bit;
 1= Set to High-level Interrupt;
 0= Set to low-level interrupt.

11.3.3 Peripheral Interrupt Flag Bit Register EIF2

0xB2	Bit7	Bit6	Bit5	Bit4	Bit3	Bit2	Bit1	Bit0
EIF2	SPIIF	I2CIF	--	ADCIF	PWMIF	--	TF4	TF3
R/W	R	R	--	R/W	R	--	R/W	R/W
Reset value	0	0	0	0	0	0	0	0

- Bit7 SPIIF: SPI global interrupt indicator bit, read-only;
 1= SPI generates an interrupt, (this bit is automatically cleared after the specific interrupt flag is cleared);
 0= The SPI did not produce an interrupt.
- Bit6 I2CIF: I2C global interrupt indicator bit, read-only;
 1= I2C produces an interrupt, (after clearing the specific interrupt flag, this bit is automatically cleared);
 0= I2C did not produce an interrupt.
- Bit5 -- Reserved, must be 0.
- Bit4 ADCIF: ADC interrupt flag bit;
 1= ADC conversion is completed, and software zeroing is required;
 0= The ADC conversion was not completed.
- Bit3 PWMIF: PWM global interrupt indicator bit, read-only;
 1= PWM generates an interrupt, (after the specific interrupt flag is cleared, this bit is automatically cleared);
 0= The PWM did not produce an interrupt.
- Bit2 -- Reserved, must be 0.
- Bit1 TF4: Timer4 timer overflow interrupt flag bit;
 1= Timer4 timer overflow, the hardware is automatically cleared when entering the interrupt service program, and the software can also be cleared;
 0= The Timer4 timer has no overflow.
- Bit0 TF3: Timer3 timer overflow interrupt flag bit;
 1= Timer3 timer overflow, when entering the interrupt service program, the hardware is automatically cleared, and the software can also be cleared;
 0= The Timer3 timer has no overflow.

11.4 Timer3 Working Mode

11.4.1 T3 - Mode 0 (13-bit Timing Mode)

In this mode, timer 3 is a 13-bit register. When all the bits of the timer are flipped from 1 to 0, the timer 3 interrupt flag TF3 is set to 1. The 13-bit register consists of TH3 and TL3 low 5 bits. TL3 high 3 bits should be ignored. The block diagram of Timer3 mode 0 is shown in the following figure:

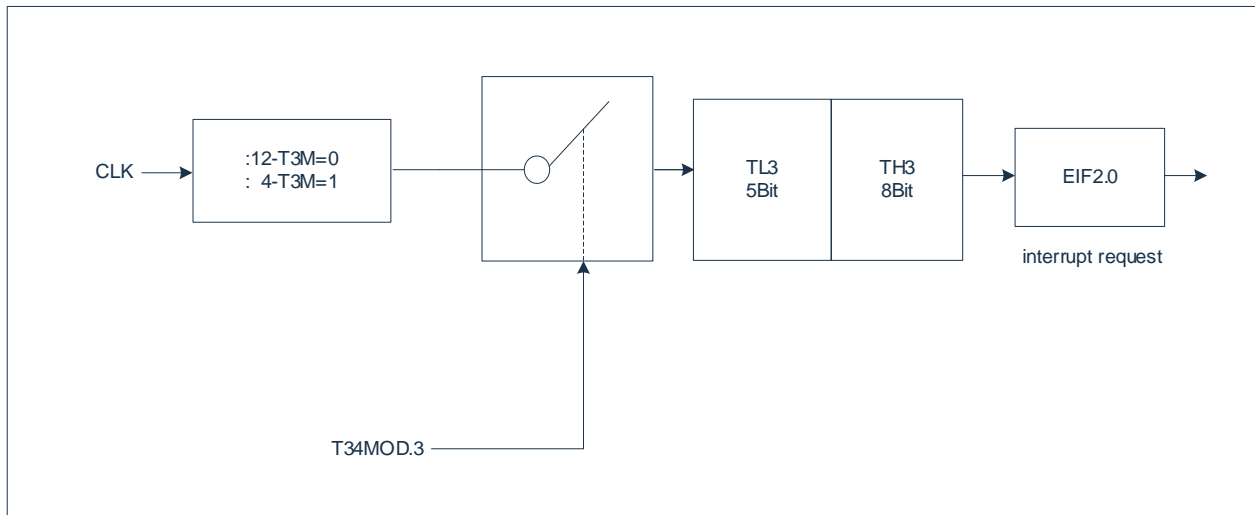

11.4.2 T3 - Mode 1 (16-bit Timing Mode)

Mode 1 is the same as mode 0, except that timer 3 registers 16 bits are all running in mode 1. The block diagram of Timer3 mode 1 is shown in the following figure:

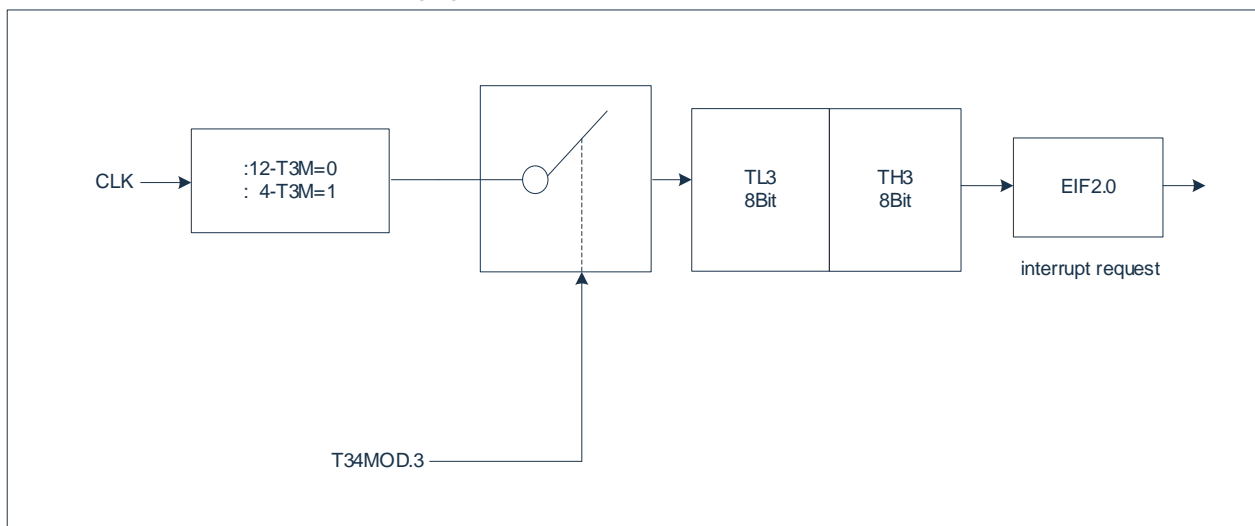

11.4.3 T3 - Mode 2 (8-bit Auto Reload Timing Mode)

The timer 3 register in mode 2 is an 8-bit timer (TL3) with auto reload mode, as shown in the figure below. The overflow from TL3 not only puts TF3 at 1, but also reloads the contents of TH3 from software to TL3. The value of TH3 remains unchanged during Reloading. The block diagram of Timer3 mode 2 is shown in the following figure:

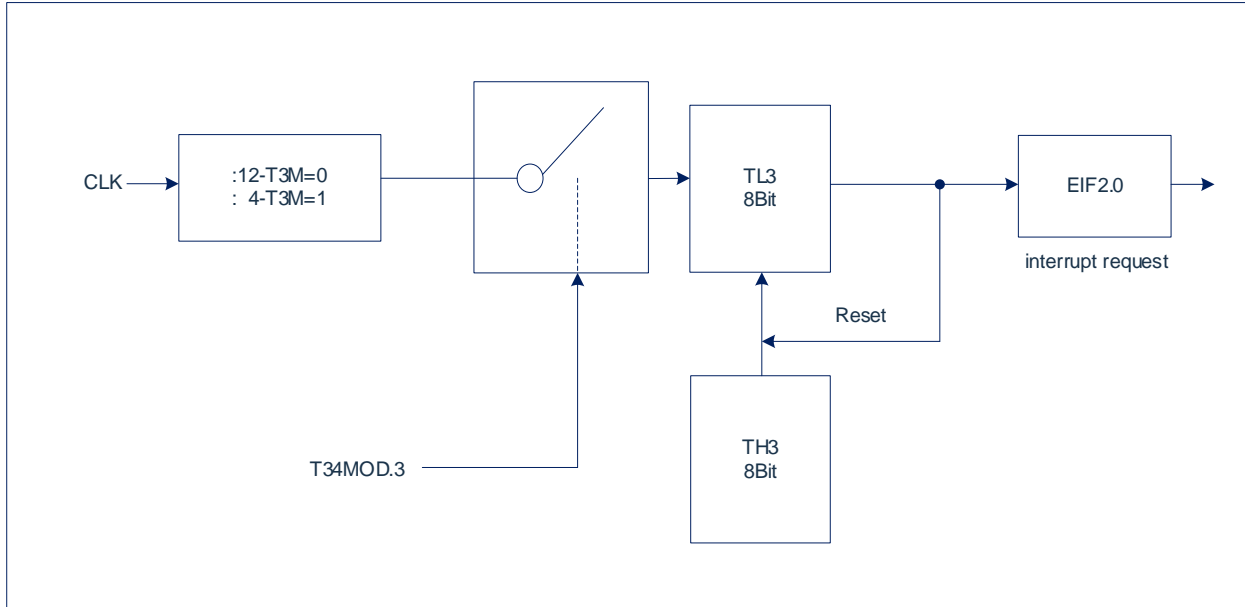

11.4.4 T3 - Mode 3 (Two Separate 8-bit Timers)

Timer 3 in mode 3 sets TL3 and TH3 to two independent timers. The logic of timer 3 mode 3 is shown in the following figure.

TL3 operates as an 8-bit timer and uses the control bits of timer 3, such as TR3, and TF3.

TH3 operates as an 8-bit timer and uses the TR4 and TF4 flags of Timer 4 and controls Timer 4 interrupts.

Mode 3 can be used when two 8-bit timers are required. When Timer 3 is in Mode 3, Timer 4 can turn it off by switching to its own Mode 3, or it can still be used as a baud rate generator by the serial channel, or in any application that does not require a timer 4 interrupt. The block diagram of Timer3 mode 3 is shown in the following figure:

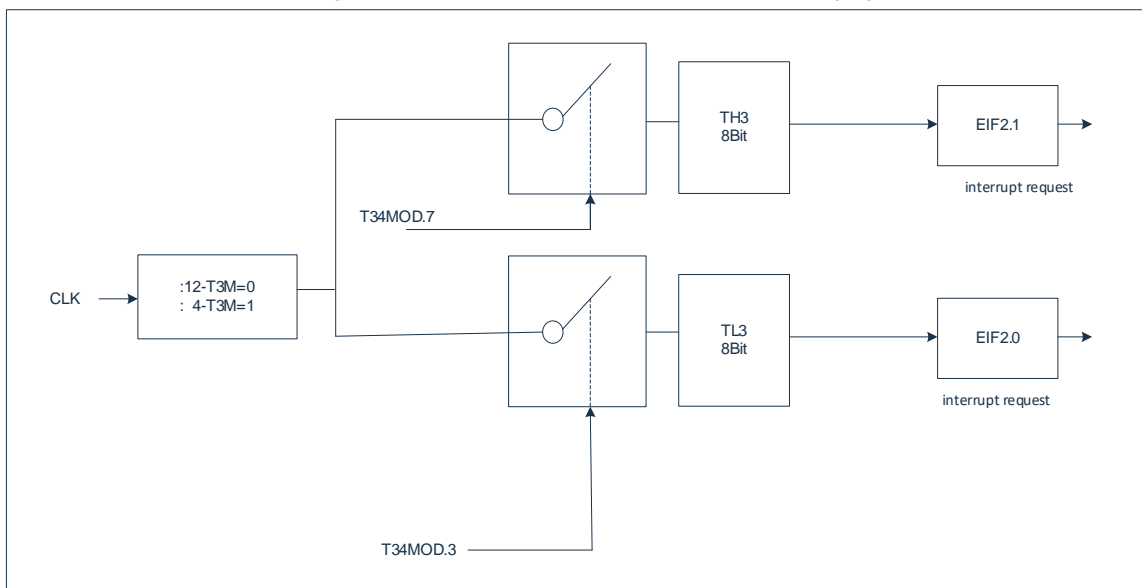

11.5 Timer4 Working Mode

11.5.1 T4 - Mode 0 (13-bit Timing Mode)

In this mode, timer 4 is a 13-bit register. When all the bits of the timer are flipped from 1 to 0, the timer 4 interrupt flag TF4 is set to 1. The 13-bit register consists of TH4 8 bits and TL4 low 5 bits. TL4 high three bits should be ignored. The block diagram of Timer4 mode 0 is shown in the following figure:

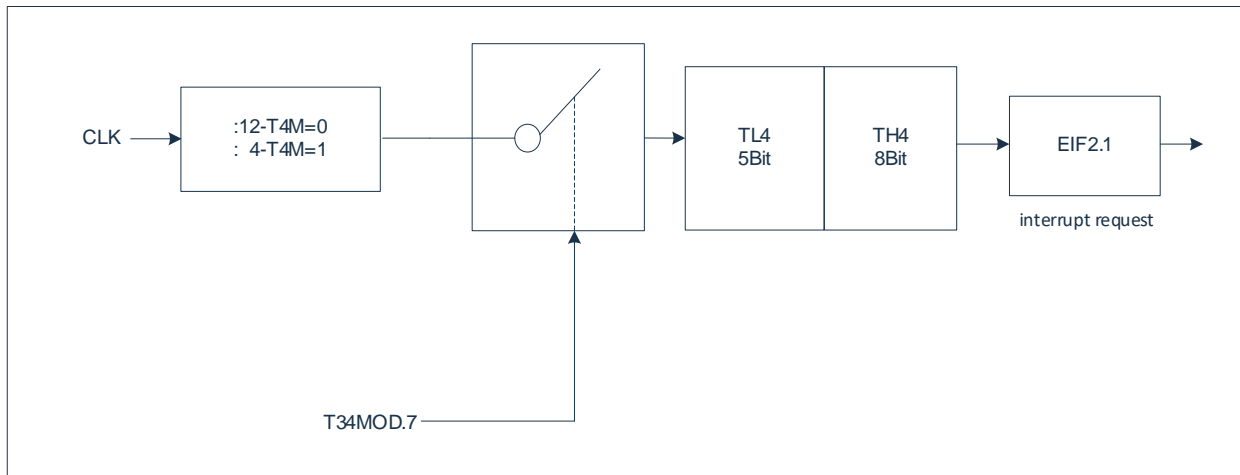

11.5.2 T4 - Mode 1 (16-bit Timing Mode)

Mode 1 is the same as Mode 0, except that the timer 4 registers 16 bits are all running in mode 1. The block diagram of Timer4 mode 1 is shown in the following figure:

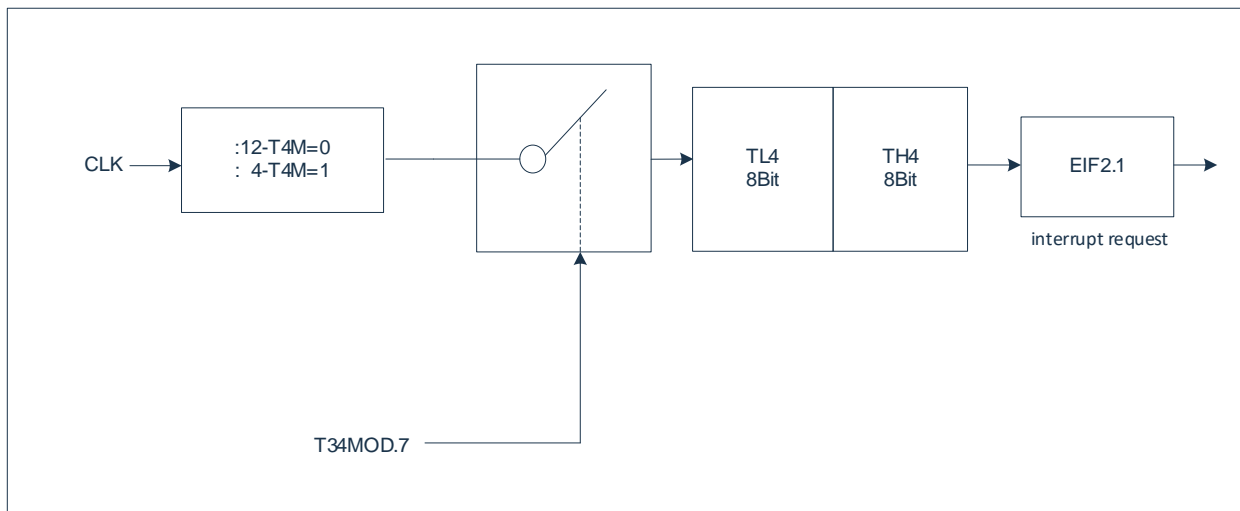

11.5.3 T4- Mode 2 (8-bit Auto Reload Timing Mode)

The timer 4 register in mode 2 is an 8-bit timer (TL4) with an auto-reload mode, as shown in the figure below. The overflow from TL4 not only makes TF4 1, but also reloads the contents of TH4 from software to TL4. The value of TH4 remains unchanged during Reloading. The block diagram of Timer4 mode 2 is shown in the following figure:

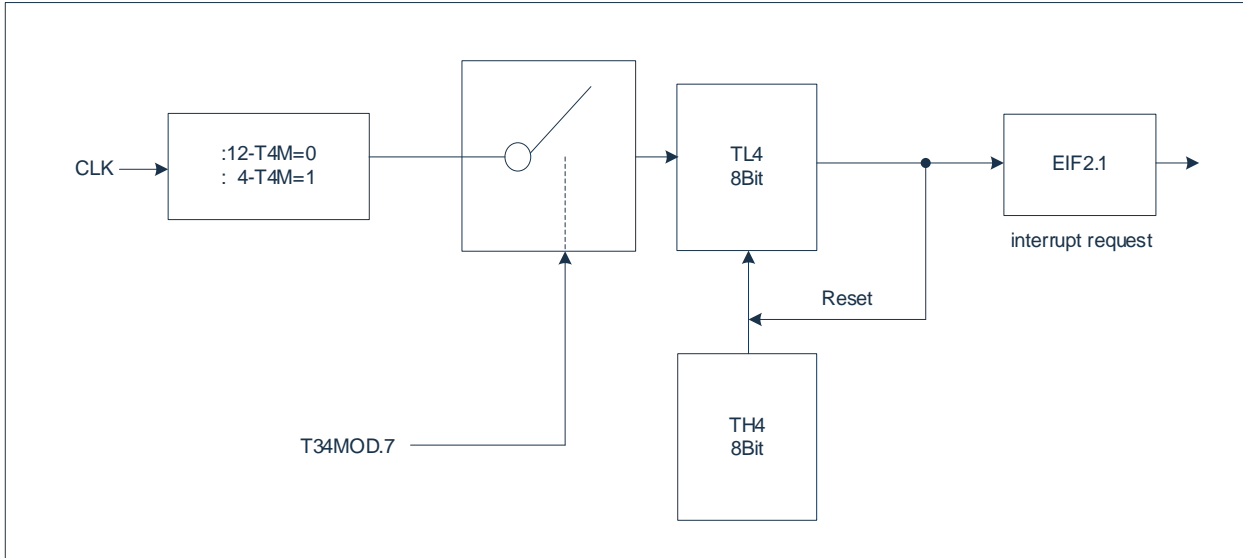

11.5.4 T4 - Mode 3 (Stop Count)

Timer 4 in mode 3 stops counting with the same effect as setting `TR4=0`.

12. LSE Timer(LSE_Timer)

12.1 Overview

The LSE timer is a clock source from an external low-speed clock LSE, a 16-bit up-counting timer. When using the LSE timer function, you should first set the LSE module to enable, wait for the LSE clock to stabilize (about 1.5s), and then set the LSE count enable. The counter adds 1 to the rising edge of the LSE clock, and when the count value is equal to the timing value, the interrupt flag LSECON[0] is set to 1, and the counter starts counting from 0 again. The timing value is set by registers {LSECRH[7:0], LSECRL[7:0]}.

If the LSE timing function is configured before hibernation, the LSE oscillator and LSE timer can continue to operate without being affected while the chip is asleep. If the LSE timed wake function is set before sleep, the system will wake up when the count value is equal to the timed value.

12.2 Related Registers

12.2.1 LSE Timer Data Register Low 8 Bit LSECRL

F694H	Bit7	Bit6	Bit5	Bit4	Bit3	Bit2	Bit1	Bit0
LSECRL	LSED7	LSED6	LSED5	LSED4	LSED3	LSED2	LSED1	LSED0
R/W	R/W	R/W	R/W	R/W	R/W	R/W	R/W	R/W
Reset value	1	1	1	1	1	1	1	1

Bit7~Bit0 LSED<7:0>: LSE timing/wake-up time data is 8 bits lower.

12.2.2 LSE Timer Data Registers are 8 Bits High LSECRH

F695H	Bit7	Bit6	Bit5	Bit4	Bit3	Bit2	Bit1	Bit0
LSECRH	LSED15	LSED14	LSED13	LSED12	LSED11	LSED10	LSED9	LSED8
R/W	R/W	R/W	R/W	R/W	R/W	R/W	R/W	R/W
Reset value	1	1	1	1	1	1	1	1

Bit7~Bit0 LSED<15:8>: LSE timing/wake-up time data is 8 bits higher.

12.2.3 LSE Timer Control Register LSECON

F696H	Bit7	Bit6	Bit5	Bit4	Bit3	Bit2	Bit1	Bit0
LSECON	LSEEN	LSEWUEN	LSECNTEN	LSESTA	LSEIE	--	--	LSEIF
R/W	R/W	R/W	R/W	R/W	R/W	R/W	R/W	R/W
Reset value	0	0	0	0	0	0	0	0

Bit7	LSEEN: LSE module enable control; 1= Enable; 0= Disable.
Bit6	LSEWUEN: LSE timer wake-up enable control; 1= Enable; 0= Disable.
Bit5	LSECNTEN: LSE as timer count enable control; 1= Enable; 0= Disable.
Bit4	LSESTA: LSE steady-state bit, read-only; 1= LSE stability; 0= The LSE is not stable.
Bit3	LSEIE: LSE as timer interrupt enable control; 1= Enable; 0= Disable.
Bit2~Bit1	-- Reserved, must be 0.
Bit0	LSEIF: LSE as timer interrupt flag bit (software clear 0); 1= An interrupt is generated. 0= No interrupts were generated or the breaks were cleared to zero out.

12.3 Interrupt With Sleep Wake-up

The LSE timer can enable or disable interrupts via LSECON registers, setting high/low priority via EIP3 registers, where the relevant bits are described as following.

0xBB	Bit7	Bit6	Bit5	Bit4	Bit3	Bit2	Bit1	Bit0
EIP3	--	--	--	--	PLVD	PLSE	--	--
R/W	R/W	R/W	R/W	R/W	R/W	R/W	R/W	R/W
Reset value	0	0	0	0	0	0	0	0

Bit7~Bit5	--	Reserved, must be 0.
Bit4	PTOUCH	TOUCH interrupt priority control bit; 1= Set to High-level Interrupt; 0= Set to low-level interrupt.
Bit3	PLVD:	LVD interrupt priority control bit; 1= Set to High-level Interrupt; 0= Set to low-level interrupt.
Bit2	PLSE:	LSE interrupt priority control bit; 1= Set to High-level Interrupt; 0= Set to low-level interrupt.
Bit1~Bit0	--	Reserved, must be 0.

When the count value of the LSE timer is equal to the timer value, the off flag bit LSEIF in the timer is set to 1. If the global interrupt is enabled (EA=1) and the LSE timer interrupt is enabled (LSEIE=1), the CPU executes the interrupt service program.

Using LSE timed interrupt wake-up sleep mode, you need to enable LSEEN, LSECNT, LSEWUEN before hibernation, and set the post-hibernation state to wake up time. If the global interrupt enable and LSE interrupt enable are turned on before hibernation, after hibernation wakes up, the interrupt service program is executed first, and the next instruction of the hibernation instruction is executed after the interrupt returns. { LSECRH[7:0], LSECRL[7:0]}

12.4 Feature Description

To use the LSE timer function, you need to set LSEEN=1 to enable the LSE timer function module, and then wait for the LSE clock steady state bit LSESTA=1, then configure the LSE timing value {LSECRH[7:0], LSECRL[7:0]}, and finally set LSECNT=1, enable LSE count, and turn on the LSE count function. The LSE timer counts from 0, interrupt flag bit set to 1 when the count value is equal to the timing value, and update the timing value to the value in the timer data register (i.e. the LSE timing value is the last time {LSECRH[7:0], LSECRL[7:0]} value is written before the LSE timing value is equal to the count value and the timing value). The minimum timer value is 1, if the timer value is set to 0, the timer defaults to 1 as the timer value. The LSE timer configured time calculation formula is as follows:

$$\text{LSE configured time} = \frac{1}{32.768} \times (\{ \text{LSECRH}[7:0], \text{LSECRL}[7:0] \} + 1) \text{ ms}$$

LSEEN, LSECNTEN, LSESTA any bit of the LSE timer is 0, and the count value of the LSE will be cleared.

13. Wake-up Timer (WUT)

13.1 Overview

Wake Up Timer is a clock source from the internal low-speed clock LSI, a 12-bit, up-count timer for sleep wake-ups that can be used to time-wake systems in sleep mode. Configure the timed wake-up time before the system goes to sleep and enable the timed wake-up function. When the chip enters sleep mode, THE WUT starts counting, and when the count value is equal to the set value, the chip enters the sleep wake-up waiting state, the timer overflows state set to 1, and the software clears 0.

13.2 Related Registers

13.2.1 WUTCRH Register

0xBD	Bit7	Bit6	Bit5	Bit4	Bit3	Bit2	Bit1	Bit0
WUTCRH	WUTEN	TIMER_OV	WUTPS1	WUTPS0	WUTD11	WUTD10	WUTD9	WUTD8
R/W	R/W	R	R/W	R/W	R/W	R/W	R/W	R/W
Reset value	0	0	0	0	0	0	0	0

Bit7 WUTEN: Timed wake-up function enable bit;
 1= The timed wake-up function is turned on;
 0= The timed wake-up function is disabled.

Bit6 TIMER_OV: Timer overflow status bit;
 1= Counter overflow;
 0= Software clear 0.

Bit5~Bit4 WUTPS<1:0>: Timed wake-up counter clock divider;
 00= F/1;
 01= F/8;
 10= F/32;
 11= F/256.

Bit3~Bit0 WUTD<11:8>: The timed wake-up time data is 4 bits higher.

13.2.2 WUTCRL Register

0xBC	Bit7	Bit6	Bit5	Bit4	Bit3	Bit2	Bit1	Bit0
WUTCRL	WUTD7	WUTD6	WUTD5	WUTD4	WUTD3	WUTD2	WUTD1	WUTD0
R/W	R/W	R/W	R/W	R/W	R/W	R/W	R/W	R/W
Reset value	0	0	0	0	0	0	0	0

Bit7~Bit0 WUTD<7:0>: The timed wake-up time data is 8 bits lower.

13.3 Feature Description

The internal wake-up timer works on the principle that after the system enters sleep mode, the CPU stops working with all peripheral circuitry, and the internal low-power oscillator LSI begins to operate, and its oscillation clock is 125KHz ($T_{LSI} \approx 8\mu s$).

Provides a clock for the WUT counter.

There are two internal wake-up timer registers: WUTCRH and WUTRCL.

Bit7 of the WUTCRH register is an internal timed wake-up enable bit:

- WUTEN=1: Turn on the timed wake-up function;
- WUTEN=0: Turns off timed wake-up.

{WUTCRH[3:0] and WUTRCL[7:0]} form a 12-bit timed wake-up data register, after entering sleep mode, the WUT counter starts to time, when the value of the WUT counter is equal to the value of the timed wake-up data register, start the system oscillator, enter the wake-up waiting state.

Timed wake-up time: $T=(WUTD[11:0]+1) \times WUTPS \times T_{LSI}$

14. Baud Rate Timer (BRT)

14.1 Overview

The chip has a 16-bit baud rate timer BRT, which mainly provides a clock for the UART module.

14.2 Related Registers

14.2.1 BRT Module Control Register BRTCon

F5C0H	Bit7	Bit6	Bit5	Bit4	Bit3	Bit2	Bit1	Bit0
BRTCON	BRTEN	--	--	--	--	BRTCKDIV2	BRTCKDIV1	BRTCKDIV0
R/W	R/W	R/W	R/W	R/W	R/W	R/W	R/W	R/W
Reset value	0	0	0	0	0	0	0	0

Bit7	BRTEN: BRT timer enable bit;
	1= Enable;
	0= Disable.
Bit6~Bit3	-- Reserved, both 0;
Bit2~Bit0	BRTCKDIV<2:0> BRT timer prescale selection bit;
	000= Fsys/1;
	001= Fsys/2;
	010= Fsys/4;
	011= Fsys/8;
	100= Fsys/16;
	101= Fsys/32;
	110= Fsys/64;
	111= Fsys/128.

14.2.2 The BRT Timer Data is Loaded With a Low 8-bit Register BRTDL

F5C1H	Bit7	Bit6	Bit5	Bit4	Bit3	Bit2	Bit1	Bit0
BRTDL	BRTDL7	BRTDL6	BRTDL5	BRTDL4	BRTDL3	BRTDL2	BRTDL1	BRTDL0
R/W	R/W	R/W	R/W	R/W	R/W	R/W	R/W	R/W
Reset value	0	0	0	0	0	0	0	0

Bit7~Bit0 BRTDL<7:0>: BRT timer load value 8 bits lower;

14.2.3 The BRT Timer Data is Loaded With a High 8-bit Register BRTDH

F5C2H	Bit7	Bit6	Bit5	Bit4	Bit3	Bit2	Bit1	Bit0
BRTDH	BRTDH7	BRTDH6	BRTDH5	BRTDH4	BRTDH3	BRTDH2	BRTDH1	BRTDH0
R/W	R/W	R/W	R/W	R/W	R/W	R/W	R/W	R/W
Reset value	0	0	0	0	0	0	0	0

Bit7~Bit0 BRTDH<7:0>: BRT timer load value 8 bits higher;

14.3 Feature Description

The BRT has a 16-bit increment counter, the clock is derived from the pre-division circuit, the pre-division clock is determined by the timer pre-division select bit BRTCKDIV, and the initial value of the counter is loaded by {BRTDH, BRTDL}.

When the timer enable bit BRTEN=1 is turned on, the counter starts working. When the value of the 16-bit counter is equal to FFFFH, the BRT counter overflows. After the overflow, the initial value of the count is automatically loaded into the counter and then the count is re-counted.

The overflow signal of the BRT counter is specially provided to the UART module as a clock source for the baud rate, and there is no interrupt when overflowing, and there is no corresponding interrupt structure. BrT in debug mode, its clock does not stop, if the UART module has begun to send or receive data, even if the chip into a suspended state, the UART will complete the entire process of sending or receiving.

BRT timer overflow rate:

$$BRT_{ov} = \frac{F_{sys}}{(65536 - \{BRTDH, BRTDL\}) \times 2^{BRTCKDIV}}$$

15. Cyclic Redundancy Check Unit (CRC)

15.1 Overview

In order to ensure safety during operation, the IEC61508 standard requires that data be confirmed even during CPU operation. This universal CRC module performs CRC operations as a peripheral function during CPU operation. The universal CRC module performs CRC checks by specifying the data to be confirmed by the program, and is not limited to the code flash memory area but can be used for multi-purpose checks.

The CRC generation polynomial uses CRC16-CCITT's " $X^{16}+X^{12}+X^5+1$ ".

15.2 Related Registers

15.2.1 CRC Data Input Register CRCHIN

F708H	Bit7	Bit6	Bit5	Bit4	Bit3	Bit2	Bit1	Bit0
CRCIN	CRCIN7	CRCIN6	CRCIN5	CRCIN4	CRCIN3	CRCIN2	CRCIN1	CRCIN0
R/W	R/W	R/W	R/W	R/W	R/W	R/W	R/W	R/W
Reset value	0	0	0	0	0	0	0	0

Bit7~Bit0 CRCIN<7:0> Enter the 8-bit data that requires CRC operation.

15.2.2 The CRC Operation Results in a Low 8-bit Data Register, CRCDL

F709H	Bit7	Bit6	Bit5	Bit4	Bit3	Bit2	Bit1	Bit0
CRCDL	CRCD7	CRCD6	CRCD5	CRCD4	CRCD3	CRCD2	CRCD1	CRCD0
R/W	R/W	R/W	R/W	R/W	R/W	R/W	R/W	R/W
Reset value	0	0	0	0	0	0	0	0

Bit7~Bit0 CRCD<7:0> The CRC operation results in 8 bits lower data

15.2.3 The CRC Operation Results in a High 8-bit Data Register With CRCDH

F70AH	Bit7	Bit6	Bit5	Bit4	Bit3	Bit2	Bit1	Bit0
CRCDH	CRCD15	CRCD14	CRCD13	CRCD12	CRCD11	CRCD10	CRCD9	CRCD8
R/W	R/W	R/W	R/W	R/W	R/W	R/W	R/W	R/W
Reset value	0	0	0	0	0	0	0	0

Bit7~Bit0 CRCD<15:8> The CRC operation results in 8 bits higher data

15.3 Feature Description

After writing the CRCIN register, a system clock is passed to save the CRC operation result to the CRCDL/CRCDH register. If necessary, the data of the previous operation must be read before writing, otherwise it will be overwritten by the new operation result.

For example, send the data "12345678H", write the value to the CRCN register in the order of "12H", "34H", "56H", "78H", read from the CRCRDL/CRCDH register as CRCDL=0xF0, CRCDH=0x67, that is, the result of the CRC operation in the bit order of the data "12345678H" is 0x67F0. Register operation is as follows:

```
CRCIN=0x12;//First number sent
```

```
CRCIN=0x34;//Send the second number
```

```
CRCIN=0x56;//Send the third number
```

```
CRCIN=0x78;//Fourth number sent
```

```
resl=CRCDL;//Read the 8 bits lower of the CRC operation result to the variable resl
```

```
resh=CRCDH;//Read the CRC operation result by bits 8 to the variable resh
```

16. Buzzer Driver (BUZZER)

16.1 Overview

The buzzer drive module consists of an 8-bit counter, a clock driver, and a control register. The buzzer drives a 50% duty-square wave with a frequency set by registers BUZCON and BUZDIV, and its frequency output covers a wide range.

16.2 Related Registers

16.2.1 BUZZER Control Register BUZCON

0xBF	Bit7	Bit6	Bit5	Bit4	Bit3	Bit2	Bit1	Bit0
BUZCON	BUSEN	--	--	--	--	--	BUZCKS1	BUZCKS0
R/W	R/W	R	R	R	R	R	R/W	R/W
Reset value	0	0	0	0	0	0	0	0

Bit7	BUSEN: BUZZER enable bit; 1= Enable; 0= Disable.
Bit6~Bit2	-- Reserved, must be 0.
Bit1~Bit0	BUZCKS<1:0>: BUZZER divide-by-side ratio select bits; 00= Fsys/8; 01= Fsys/16; 10= Fsys/32; 11= Fsys/64.

16.2.2 BUZZER Frequency Control Register BUZDIV

0xBE	Bit7	Bit6	Bit5	Bit4	Bit3	Bit2	Bit1	Bit0
BUZDIV	BUZDIV7	BUZDIV6	BUZDIV5	BUZDIV4	BUZDIV3	BUZDIV2	BUZDIV1	BUZDIV0
R/W	R/W	R/W	R/W	R/W	R/W	R/W	R/W	R/W
Reset value	0	0	0	0	0	0	0	0

Bit7~Bit0	BUZDIV<7:0>: BUZZER frequency select bit; 0x00= No square wave output; Other = $F_{buz} = F_{sys} / (2 * CLKDIV * BUZCKS)$.
-----------	--

Note: It is not recommended to modify BUZDIV during BUZEN=1.

16.3 Feature Description

When using a buzzer, you need to configure the corresponding port as a buzzer-driven output. For example, configure the P16 as a buzzer drive output port, the configuration is as follows:

P16CFG = 0x04; The P16 is configured as a buzzer drive output

By configuring the Related Registers of the buzzer drive module, it is possible to set the different frequencies at which the buzzer drive outputs. For example:

- 1) Set Fsys= 8MHz, BUZCK < 1:0>=01, and BUZDIV=125

The buzzer drive output frequency is: $F_{buz} = 8\text{MHz} / (2 * 125) / 16 = 2\text{KHz}$

- 2) Set Fsys=16MHz, BUZCK < 1:0>=11, and BUZDIV=125

The buzzer drive output frequency is: $F_{buz} = 16\text{MHz} / (2 * 125) / 64 = 1\text{KHz}$

- 3) Set Fsys=24MHz, BUZCK < 1:0>=11, and BUZDIV=94

The buzzer drive output frequency is: $F_{buz} = 24\text{MHz} / (2 * 94) / 64 = 2\text{KHz}$

Different system clock frequencies and buzzer-driven clock divide ratios can be selected to obtain different output frequencies. The buzzer drive output frequency is shown in the following table:

BUZCK<1:0>	Fbuz@Fsys=8MHz	Fbuz@Fsys=16MHz	Fbuz@Fsys=24MHz	Fbuz@Fsys=48MHz
00	2KHz~500KHz	4KHz~1MHz	6KHz~1.5MHz	12KHz~3MHz
01	1KHz~250KHz	2KHz~500KHz	3KHz~750KHz	6KHz~1.5MHz
10	0.5KHz~125KHz	1KHz~250KHz	1.5KHz~375KHz	3KHz~750KHz
11	0.25KHz~62.5KHz	0.5KHz~125KHz	0.75KHz~187.5KHz	1.5KHz~375KHz

17. PWM Module

17.1 Overview

The PWM module supports six PWM generators, which can be configured as 6 independent PWM outputs (PG0-PG5), or as 3 sets of synchronous PWM outputs, or 3 pairs of complementary PWM outputs with programmable dead-zone generators, where PG0-PG1, PG2-PG3, and PG4-PG5 are paired.

Each PWM has its own 16-bit cycle register, a 16-bit duty cycle register (comparison data register) to configure the cycle of the PWM output and adjust the duty cycle. Each PWM has its own clock-divider control registers, and each pair of PWMs shares an 8-bit prescale control register.

Each PWM can be configured in edge alignment counting mode. Each PWM can be set in single mode (generating a PWM signal cycle) or autoloading (continuous output PWM waveform) outputs, and its output polarity can also be set via the output polarity controller.

PWM supports interrupt functionality. The 6-way PWM generator provides a total of 12 interrupt flags, including a zero interrupt, a down-and-down comparison interrupt, which shares a single interrupt vector entry.

17.2 Characteristic

The PWM module has the following features:

- ◆ 6 independent 16-bit PWM control modes.
 - 6 independent outputs: PG0, PG1, PG2, PG3, PG4, PG5;
 - - 3 sets of complementary PWM pair outputs: (PG0-PG1), (PG2-PG3), (PG4-PG5), programmable dead-zone can be inserted;
 - - 3 sets of synchronous PWM pair outputs: (PG0-PG1), (PG2-PG3), (PG4-PG5), each set of PWM pair pin synchronization.
- ◆ Support group control, PG0, PG2, PG4 output synchronization, PG1, PG3, PG5 output synchronization.
- ◆ Edge alignment mode is supported.
- ◆ Support single-shot mode or auto-load mode.
- ◆ Each PWM has independent polarity control.
- ◆ The PWM edge triggers the initiation of AD conversion.

17.3 Port Configuration

Before using the PWM module, you need to configure the corresponding port as a PWM channel, and the PWM channel is marked with PG0~PG5 on the multiplexing function allocation table, corresponding to PWM channel 0~5.

The allocation of PWM channels is controlled by the corresponding port configuration registers, for example:

P00CFG=0x05; Configure the P00 as a PG0 channel

P01CFG=0x05; Configure P01 as PG1 channel

P02CFG=0x05; Configure P02 as a PG2 channel

P03CFG=0x05; Configure the P03 as a PG3 channel

P04CFG=0x05; Configure the P04 as a PG4 channel

P05CFG=0x05; Configure the P05 as a PG5 channel

17.4 Feature Description

17.4.1 Functional Block Diagram

PWM consists of a clock control module, a PWM counter module, an output comparison unit, a waveform generator, and an output controller, and its block diagram is shown in the following figure:

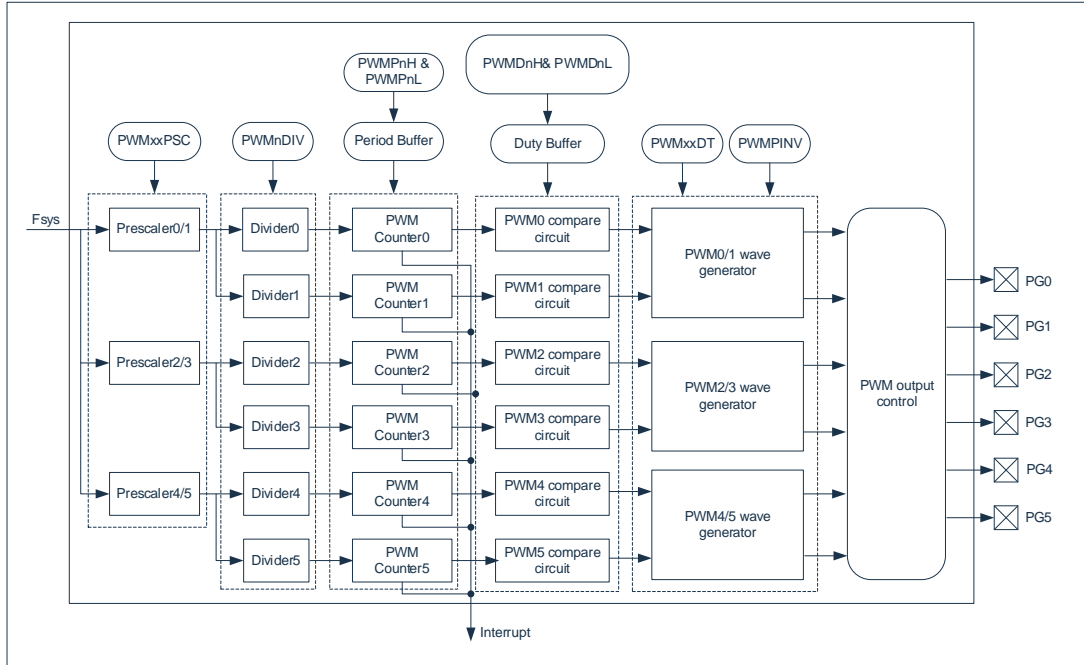

17.4.2 Edge Alignment

In edge alignment mode, the 16-bit PWM counter CNTn starts counting down at the beginning of each cycle and compares to the value CMPn locked in the PWMDnH/PWMDnL register, when CNTn= CMPn PGN outputs high, PWMnDIF is set to 1. CNTn continues to count down to 0, at which point PGN will output low and PWMnZIF will be set to 1. When the CNTn count reaches zero, if PWMnCNTM=1, CMPn and PERIODn will be reloaded.

The relevant parameters for edge alignment are as follows:

High time = $(CMPn+1) \times T_{pwm}$ ($CMPn \geq 1$).

Period = $(PERIODn+1) \times T_{pewm}$

Duty cycle = $CMPn+1PERIODn+1$ ($CMPn \geq 1$).

At $CMPn=0$, the duty cycle is 0%.

Edge alignment timing is shown in the following figure:

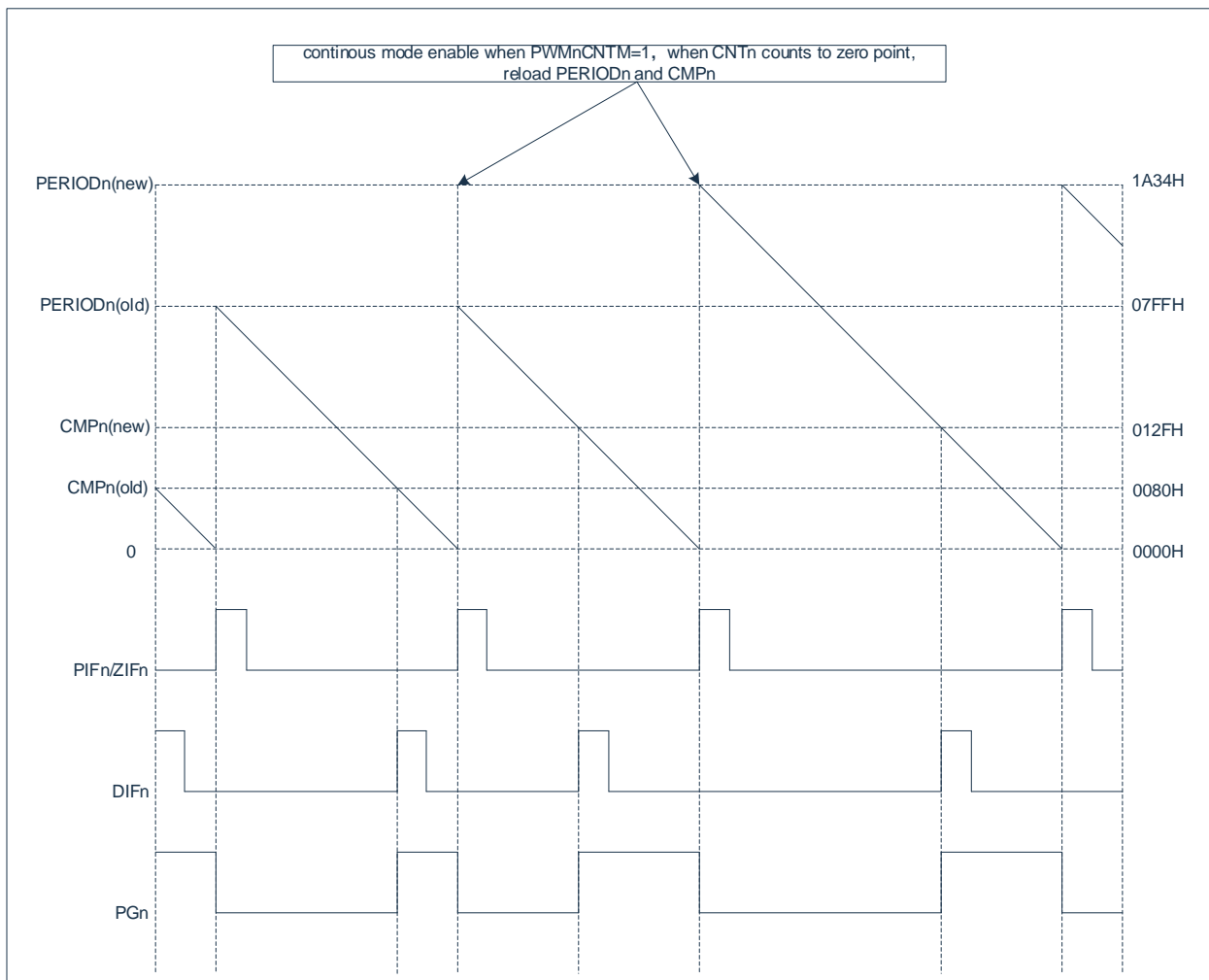

17.4.3 Complementary Model

6 PWM can be set up as 3 sets of complementary PWM pairs. In the complementary mode, the cycle, duty cycle and clock divider control of PG1, PG3, and PG5 are determined by the PG0, PG2, and PG4 related registers, respectively, that is, in addition to the corresponding output enable control bits (PWMnOE), the PG1, PG3, and PG5 output waveforms are no longer controlled by their own registers.

In complementary mode, each set of complementary PWM pairs supports inserting a dead-band delay, and the inserted dead-zone time is as follows:

$$\text{PWM0/1 Dead-zone: } (\text{PWM01DT}+1) \cdot T_{\text{PWM0}};$$

$$\text{PWM2/3 Dead-zone: } (\text{PWM23DT}+1) \cdot T_{\text{PWM2}};$$

$$\text{PWM4/5 Dead-zone: } (\text{PWM45DT}+1) \cdot T_{\text{PWM4}};$$

$T_{\text{PWM0}}/T_{\text{PWM2}}/T_{\text{PWM4}}$ are the clock source cycles of PG0/PG2/PG4, respectively.

Taking PG0/PG1 as an example, the waveform diagram without dead band in complementary mode is shown in the following figure:

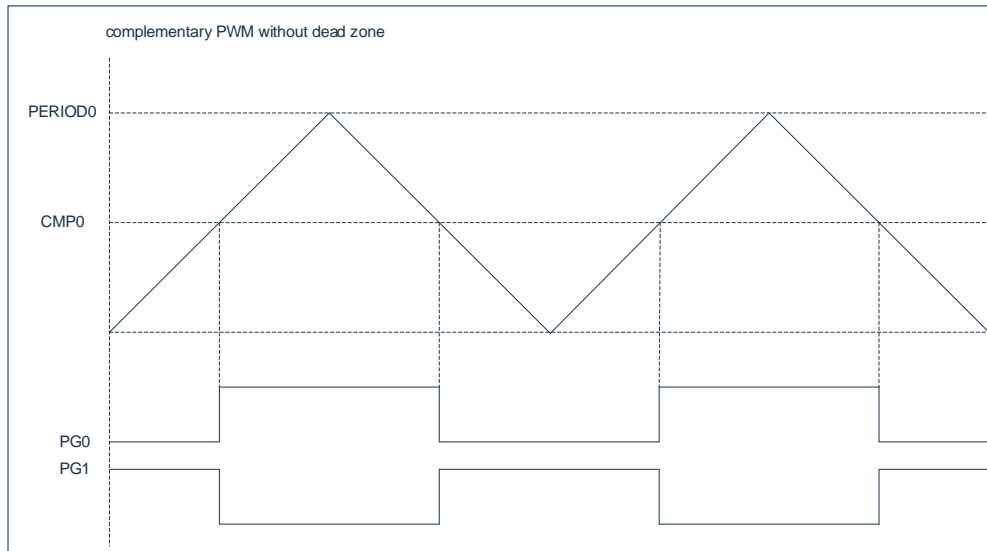

Taking PG0/PG1 as an example, the waveform graph with dead zone in complementary mode is shown in the following figure:

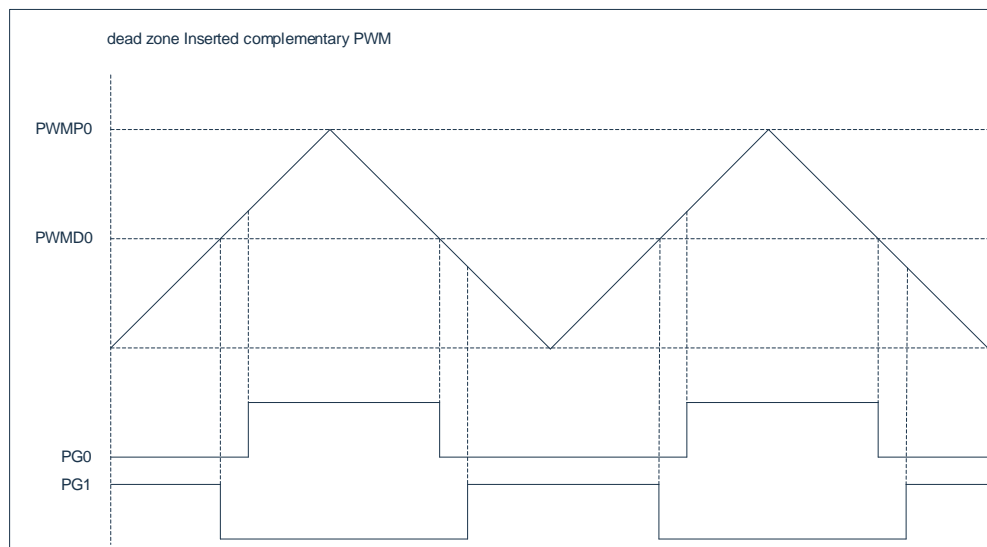

17.4.4 Synchronous Mode

6-channel PWM can be set to 3 sets of synchronous PWM pairs. In synchronous mode, the period, duty cycle and clock divider control of PG1, PG3, PG5 are determined by the PG0, PG2, PG4 related registers respectively, that is, in addition to the corresponding output enable control bit (PWMnOE), the PG1, PG3, PG5 output waveforms are no longer controlled by their own registers, PG1 output waveforms are similar to PG0, PG3 output waveforms are PG2, and PG5 output waveforms are similar to PG4.

17.5 PWM-related Registers

17.5.1 PWM Control Register PWMCON

F120H	Bit7	Bit6	Bit5	Bit4	Bit3	Bit2	Bit1	Bit0
PWMCON	--	PWMRUN	PWMMODE1	PWMMODE0	GROUPEN	--	--	--
R/W	R/W	R/W	R/W	R/W	R/W	R/W	R/W	R/W
Reset value	0	0	0	0	0	0	0	0

Bit7	--	Reserved, must be 0.
Bit6	PWMRUN:	PWM clock pre-division, clock division enable bit; 1= Prohibition (PWMmnPSC, PWMmnDIV are cleared 0); 0= Enable.
Bit5~Bit4	PWMMODE<1:0>:	Mode control bit of PWM; 00= Standalone mode; 01= Complementary models; 10= Synchronous mode; 11= Retain.
Bit3	GROUPEN:	PWM teaming function enable bit; 1= PG0 controls PG2, PG4; PG1 controls PG3, PG5; 0= All PWM channel signals are independent of each other.
Bit2	--	Reserved, must be 0.
Bit1	--	Reserved, must be 0.
Bit0	--	Reserved, must be 0.

17.5.2 PWM Output Enable Control Register PWMOE

F121H	Bit7	Bit6	Bit5	Bit4	Bit3	Bit2	Bit1	Bit0
PWMOE	--	--	PWM5OE	PWM4OE	PWM3OE	PWM2OE	PWM1OE	PWM0OE
R/W	R/W	R/W	R/W	R/W	R/W	R/W	R/W	R/W
Reset value	0	0	0	0	0	0	0	0

- Bit7~Bit6 -- Reserved, must be 0.
- Bit5 PWM5OE: Output enable bit of PWM channel 5;
 1= Enable;
 0= Disable.
- Bit4 PWM4OE: Output enable bit of PWM channel 4;
 1= Enable;
 0= Disable.
- Bit3 PWM3OE: Output enable bit of PWM channel 3;
 1= Enable;
 0= Disable.
- Bit2 PWM2OE: Output enable bit of PWM channel 2;
 1= Enable;
 0= Disable.
- Bit1 PWM1OE: Output enable bit of PWM channel 1;
 1= Enable;
 0= Disable.
- Bit0 PWM0OE: Output enable bit of PWM channel 0;
 1= Enable;
 0= Disable.

17.5.3 PWM0/1 Clock Prescale Control Register PWM01PSC

F123H	Bit7	Bit6	Bit5	Bit4	Bit3	Bit2	Bit1	Bit0
PWM01PSC	PWM01PSC7	PWM01PSC6	PWM01PSC5	PWM01PSC4	PWM01PSC3	PWM01PSC2	PWM01PSC1	PWM01PSC0
R/W	R/W	R/W	R/W	R/W	R/W	R/W	R/W	R/W
Reset value	0	0	0	0	0	0	0	0

- Bit7~Bit0 PWM01PSC<7:0>: PWM channel 0/1 prescale control bit;
 00= The prescaler clock stops, the counter of PWM0/1 stops;
 Other = The system clock is divided (PWM01PSC+1).

17.5.4 PWM2/3 Clock Prescale Control Register PWM23PSC

F124H	Bit7	Bit6	Bit5	Bit4	Bit3	Bit2	Bit1	Bit0
PWM23PSC	PWM23PSC7	PWM23PSC6	PWM23PSC5	PWM23PSC4	PWM23PSC3	PWM23PSC2	PWM23PSC1	PWM23PSC0
R/W	R/W	R/W	R/W	R/W	R/W	R/W	R/W	R/W
Reset value	0	0	0	0	0	0	0	0

- Bit7~Bit0 PWM23PSC<7:0>: PWM channel 2/3 prescale control bit;
 00= Prescale clock stop, PWM2/3 counter stop;
 Other = (PWM23PSC+1) division of the system clock.

17.5.8 PWM Output Polarity Control Register PWMPINV

F122H	Bit7	Bit6	Bit5	Bit4	Bit3	Bit2	Bit1	Bit0
PWMPINV	--	--	PWM5PINV	PWM4PINV	PWM3PINV	PWM2PINV	PWM1PINV	PWM0PINV
R/W	R/W	R/W	R/W	R/W	R/W	R/W	R/W	R/W
Reset value	0	0	0	0	0	0	0	0

Bit7~Bit6 -- Reserved, must be 0.
 Bit5~Bit0 PWMnPINV: PWM channel n output polarity control bit (n=0-5);
 1= Reverse output;
 0= Normal output.

17.5.9 PWM Counter Mode Control Register PWMCNTM

F127H	Bit7	Bit6	Bit5	Bit4	Bit3	Bit2	Bit1	Bit0
PWMCNTM	--	--	PWM5CNTM	PWM4CNTM	PWM3CNTM	PWM2CNTM	PWM1CNTM	PWM0CNTM
R/W	R/W	R/W	R/W	R/W	R/W	R/W	R/W	R/W
Reset value	0	0	0	0	0	0	0	0

Bit7~Bit6 -- Reserved, must be 0.
 Bit5~Bit0 PWMnCNTM: PWM channel n counter mode control bit (n=0-5);
 1= Auto loading mode;
 0= One-shot mode.

17.5.10 PWM Counter Enable Control Register PWMCNTE

F126H	Bit7	Bit6	Bit5	Bit4	Bit3	Bit2	Bit1	Bit0
PWMCNTE	--	--	PWM5CNTE	PWM4CNTE	PWM3CNTE	PWM2CNTE	PWM1CNTE	PWM0CNTE
R/W	R/W	R/W	R/W	R/W	R/W	R/W	R/W	R/W
Reset value	0	0	0	0	0	0	0	0

Bit7~Bit6 -- Reserved, must be 0.
 Bit5~Bit0 PWMnCNTE: PWM channel n counter enables control bits (n=0-5);
 1= PWMn counter on (PWMn starts output);
 0= The PWMn counter stops (the software writes 0 and the counter stops and clears the counter value).
 (The brake triggers the bit hardware to clear 0; Single-shot mode completes the bit hardware clearance 0)

17.5.11 PWM Counter Mode Control Register PWMCNTCLR

F128H	Bit7	Bit6	Bit5	Bit4	Bit3	Bit2	Bit1	Bit0
PWMCNTCLR	--	--	PWM5CNTCLR	PWM4CNTCLR	PWM3CNTCLR	PWM2CNTCLR	PWM1CNTCLR	PWM0CNTCLR
R/W	R/W	R/W	R/W	R/W	R/W	R/W	R/W	R/W
Reset value	0	0	0	0	0	0	0	0

Bit7~Bit6 -- Reserved, must be 0.

Bit5~Bit0 PWMnCNTCLR: PWM channel n counter clear control bit (n=0-5) (hardware automatic zeroing);

1= PWMn counter clears;

0= Writing 0 is invalid.

17.5.12 PWM Cycle Data Register Low 8 Bits PWMPnL (n=0-5)

	Bit7	Bit6	Bit5	Bit4	Bit3	Bit2	Bit1	Bit0
PWMPnL	PWMPnL7	PWMPnL6	PWMPnL5	PWMPnL4	PWMPnL3	PWMPnL2	PWMPnL1	PWMPnL0
R/W	R/W	R/W	R/W	R/W	R/W	R/W	R/W	R/W
Reset value	0	0	0	0	0	0	0	0

Registers PWMPnL (n=0-5) Address: F130H, F132H, F134H, F136H, F138H, F13AH.

Bit7~Bit0 PWMPnL<7:0>: The PWM channel n-period data register is 8 bits lower.

17.5.13 PWM Cycle Data Register High 8 Bits PWMPnH (n=0-5)

	Bit7	Bit6	Bit5	Bit4	Bit3	Bit2	Bit1	Bit0
PWMPnH	PWMPnH7	PWMPnH6	PWMPnH5	PWMPnH4	PWMPnH3	PWMPnH2	PWMPnH1	PWMPnH0
R/W	R/W	R/W	R/W	R/W	R/W	R/W	R/W	R/W
Reset value	0	0	0	0	0	0	0	0

Registers PWMPnH (n=0-5) Address: F131H, F133H, F135H, F137H, F139H, F13BH.

Bit7~Bit0 PWMPnH<7:0>: The PWM channel n-period data register is 8 bits high.

17.5.14 PWM Compare Data Register Low 8 Bits PWMDnL (n=0-5)

	Bit7	Bit6	Bit5	Bit4	Bit3	Bit2	Bit1	Bit0
PWMDnL	PWMDnL7	PWMDnL6	PWMDnL5	PWMDnL4	PWMDnL3	PWMDnL2	PWMDnL1	PWMDnL0
R/W	R/W	R/W	R/W	R/W	R/W	R/W	R/W	R/W
Reset value	0	0	0	0	0	0	0	0

Registers PWMDnL (n=0-5) Address: F140H, F142H, F144H, F146H, F148H, F14AH.

Bit7~Bit0 PWMDnL<7:0>: PWM channel n compare data (duty cycle data) registers 8 bits lower.

17.5.15 PWM Compare Data Register High 8 Bits PWMDnH (n=0-5)

	Bit7	Bit6	Bit5	Bit4	Bit3	Bit2	Bit1	Bit0
PWMDnH	PWMDnH7	PWMDnH6	PWMDnH5	PWMDnH4	PWMDnH3	PWMDnH2	PWMDnH1	PWMDnH0
R/W	R/W	R/W	R/W	R/W	R/W	R/W	R/W	R/W
Reset value	0	0	0	0	0	0	0	0

Registers PWMDnH (n=0-5) Address: F141H, F143H, F145H, F147H, F149H, F14BH.

Bit7~Bit0 PWMDnH<7:0>: The PWM channel n comparison data (duty cycle data) register is 8 bits higher.

17.5.16 PWM Dead-zone Enable Control Register PWMDE

F160H	Bit7	Bit6	Bit5	Bit4	Bit3	Bit2	Bit1	Bit0
PWMDE	--	--	--	--	--	PWM45DTE	PWM23DTE	PWM01DTE
R/W	R/W	R/W	R/W	R/W	R/W	R/W	R/W	R/W
Reset value	0	0	0	0	0	0	0	0

- Bit7~Bit3 -- Reserved, must be 0.
- Bit2 PWM45DTE: PWM4/5 channel dead-zone delay enable bit;
1= Enable;
0= Disable.
- Bit1 PWM23DTE: PWM2/3 channel dead-zone delay enable bit;
1= Enable;
0= Disable.
- Bit0 PWM01DTE: PWM0/1 channel dead-zone delay enable bit;
1= Enable;
0= Disable.

17.5.17 PWM0/1 Dead-zone Delay Data Register PWM01DT

F161H	Bit7	Bit6	Bit5	Bit4	Bit3	Bit2	Bit1	Bit0
PWM01DT	PWM01DT7	PWM01DT6	PWM01DT5	PWM01DT4	PWM01DT3	PWM01DT2	PWM01DT1	PWM01DT0
R/W	R/W	R/W	R/W	R/W	R/W	R/W	R/W	R/W
Reset value	0	0	0	0	0	0	0	0

Bit7~Bit0 PWM01DT<7:0>: PWM channel 0/1 dead-zone delay data register.

17.5.18 PWM2/3 Dead-zone Delay Data Register PWM23DT

F162H	Bit7	Bit6	Bit5	Bit4	Bit3	Bit2	Bit1	Bit0
PWM23DT	PWM23DT7	PWM23DT6	PWM23DT5	PWM23DT4	PWM23DT3	PWM23DT2	PWM23DT1	PWM23DT0
R/W	R/W	R/W	R/W	R/W	R/W	R/W	R/W	R/W
Reset value	0	0	0	0	0	0	0	0

Bit7~Bit0 PWM23DT<7:0>: PWM channel 2/3 dead-zone delay data register.

17.5.19 PWM4/5 Dead-zone Delay Data Register PWM45DT

F163H	Bit7	Bit6	Bit5	Bit4	Bit3	Bit2	Bit1	Bit0
PWM45DT	PWM45DT7	PWM45DT6	PWM45DT5	PWM45DT4	PWM45DT3	PWM45DT2	PWM45DT1	PWM45DT0
R/W	R/W	R/W	R/W	R/W	R/W	R/W	R/W	R/W
Reset value	0	0	0	0	0	0	0	0

Bit7~Bit0 PWM45DT<7:0>: PWM channel 4/5 dead-zone delay data register.

17.6 PWM Interrupt

PWM has a total of 12 interrupt flags, of which 6 zero interrupt flags, 6 downward comparison interrupt flags, the generation of interrupt flag bits and the corresponding interrupt enable bit is not related to whether the corresponding interrupt enable bit is turned on. To enable PWM, any type of interrupt requires the global interrupt enable bit (EA=1) and the PWM global interrupt enable bit PWMIE to successfully configure the PWM interrupt function. All interrupts of PWM share an interrupt vector entry, so after entering the interrupt service program, the user can determine which type of interrupt is generated by the interrupt flag.

The interrupt enable and priority of the PWM can be set by the following relevant register bits.

17.6.1 Interrupt Mask Register EIE2

0xAA	Bit7	Bit6	Bit5	Bit4	Bit3	Bit2	Bit1	Bit0
EIE2	SPIIE	I2CIE	WDTIE	ADCIE	PWMIE	--	ET4	ET3
R/W	R/W	R/W	R/W	R/W	R/W	R/W	R/W	R/W
Reset value	0	0	0	0	0	0	0	0

- Bit7 SPIIE: SPI interrupt enable bit;
 1= Enable SPI interrupts;
 0= Prohibited SPI Interrupt.
- Bit6 I2CIE: I2C interrupt enable bit;
 1= Enable I2C interrupts;
 0= Disable I²C Interrupt.
- Bit5 WDTIE: WDT interrupt enable bit;
 1= Enable WDT overflow interrupts;
 0= Disable WDT overflow interrupts.
- Bit4 ADCIE: ADC interrupt enable bit;
 1= Enable ADC interrupts;
 0= Disable ADC interrupts.
- Bit3 PWMIE: PWM global interrupt enable bit;
 1= Enable all PWM interrupts;
 0= Disable all PWM interrupts.
- Bit2 -- Reserved, must be 0.
- Bit1 ET4: Timer4 interrupt enable bit;
 1= Enable Timer4 interrupts;
 0= Disable Timer4 Interrupt.
- Bit0 ET3: Timer3 interrupt enable bit;
 1= Enable Timer3 interrupts;
 0= Disable Timer3 Interrupt.

17.6.2 Interrupt Priority Control Register EIP2

0xBA	Bit7	Bit6	Bit5	Bit4	Bit3	Bit2	Bit1	Bit0
EIP2	PSPI	PI2C	PWDT	PADC	PPWM	PLED	PT4	PT3
R/W	R/W	R/W	R/W	R/W	R/W	R/W	R/W	R/W
Reset value	0	0	0	0	0	0	0	0

- Bit7 PSPI: SPI interrupt priority control bit;
 1= Set to High-level Interrupt;
 0= Set to low-level interrupt.
- Bit6 PI2C: I2C interrupt priority control bit;
 1= Set to High-level Interrupt;
 0= Set to low-level interrupt.
- Bit5 PWDT: WDT interrupt priority control bit;
 1= Set to High-level Interrupt;
 0= Set to low-level interrupt.
- Bit4 PADC: ADC interrupt priority control bit;
 1= Set to High-level Interrupt;
 0= Set to low-level interrupt.
- Bit3 PPWM: PWM interrupt priority control bit
 1= Set to High-level Interrupt;
 0= Set to low-level interrupt.
- Bit2 PLED: LED dot matrix scan interrupt priority control bit
 1= Set to High-level Interrupt;
 0= Set to low-level interrupt.
- Bit1 PT4: TIMER4 interrupt priority control bit;
 1= Set to High-level Interrupt;
 0= Set to low-level interrupt.
- Bit0 PT3: TIMER3 interrupt priority control bit;
 1= Set to High-level Interrupt;
 0= Set to low-level interrupt.

17.6.3 PWM Zero Interrupt Mask Register PWMZIE

F169H	Bit7	Bit6	Bit5	Bit4	Bit3	Bit2	Bit1	Bit0
PWMZIE	--	--	PWM5ZIE	PWM4ZIE	PWM3ZIE	PWM2ZIE	PWM1ZIE	PWM0ZIE
R/W	R/W	R/W	R/W	R/W	R/W	R/W	R/W	R/W
Reset value	0	0	0	0	0	0	0	0

- Bit7~Bit6 -- Reserved, must be 0.
- Bit5~Bit0 PWMnZIE: PWM channel n zero interrupt shield bit (n=0-5);
 1= Enable interrupts;
 0= Disable Interrupt.

17.6.4 PWM Down Compare Interrupt Mask Register PWMDIE

F16BH	Bit7	Bit6	Bit5	Bit4	Bit3	Bit2	Bit1	Bit0
PWMDIE	--	--	PWM5DIE	PWM4DIE	PWM3DIE	PWM2DIE	PWM1DIE	PWM0DIE
R/W	R/W	R/W	R/W	R/W	R/W	R/W	R/W	R/W
Reset value	0	0	0	0	0	0	0	0

Bit7~Bit6 -- Reserved, must be 0.

Bit5~Bit0 PWMnDIE: PWM channel n down compared interrupt shield bits (n=0-5);

1= Enable interrupts;

0= Disable Interrupt.

17.6.5 PWM Zero Interrupt Flag Register PWMZIF

F16DH	Bit7	Bit6	Bit5	Bit4	Bit3	Bit2	Bit1	Bit0
PWMZIF	--	--	PWM5ZIF	PWM4ZIF	PWM3ZIF	PWM2ZIF	PWM1ZIF	PWM0ZIF
R/W	R/W	R/W	R/W	R/W	R/W	R/W	R/W	R/W
Reset value	0	0	0	0	0	0	0	0

Bit7~Bit6 -- Reserved, must be 0.

Bit5~Bit0 PWMnZIF: PWM channel n zero interrupt flag bit (n=0-5);

1= generate interrupts (software zeroing);

0= No interrupt was generated.

17.6.6 PWM Down Compare Interrupt Flag Register PWMDIF

F16FH	Bit7	Bit6	Bit5	Bit4	Bit3	Bit2	Bit1	Bit0
PWMDIF	--	--	PWM5DIF	PWM4DIF	PWM3DIF	PWM2DIF	PWM1DIF	PWM0DIF
R/W	R/W	R/W	R/W	R/W	R/W	R/W	R/W	R/W
Reset value	0	0	0	0	0	0	0	0

Bit7~Bit6 -- Reserved, must be 0.

Bit5~Bit0 PWMnDIF: PWM channel n down to compare interrupt flag bits (n=0-5);

1= generate interrupts (software zeroing);

0= No interrupt was generated.

18. Hardware LED Matrix Driver

18.1 Overview

The chip integrates a hardware LED matrix driver circuit, which can facilitate the user to realize the display drive of the LED.

18.2 Characteristic

Hardware LED matrix drivers have the following characteristics:

- ◆ 1/4, 1/5, 1/6, 1/8 DUTY is available.
- ◆ Three clock sources are available: system clock, LSI, and LSE.
- ◆ 16-bit clock source crossover controller.
- ◆ Supports up to 8 COM ports and 16 SEG ports.
- ◆ COM port common-negative, common-positive two drive mode optional.
- ◆ COM port current 50 mA, 150 mA selectable ($V_{OL} = 1.5V@VDD = 5V$).
- ◆ The SEG port current is selectable in 16 steps, and the maximum current can reach 40mA ($V_{OH}=3.5V@VDD=5V$).

18.3 Related Registers

18.3.1 LED Drive Mode Select Register LEDMODE

F7690'CLOCK	Bit7	Bit6	Bit5	Bit4	Bit3	Bit2	Bit1	Bit0
LEDMODE	LEDMODE7	LEDMODE6	LEDMODE5	LEDMODE4	LEDMODE3	LEDMODE2	LEDMODE1	LEDMODE0
R/W	R/W	R/W	R/W	R/W	R/W	R/W	R/W	R/W
Reset value	0	0	0	0	0	0	0	0

- Bit7~Bit0 LEDMODE<7:0>: LED drive mode selection register;
- 0x55= The LED matrix drive mode is valid, and the relevant registers are in effect;
(Before configuring the LED matrix drive mode, the register must first write 0x55, otherwise it is invalid.))
 - 0xAA= The LED dot matrix drive mode is valid, and the relevant registers are effective;
(Before configuring led dot matrix drive mode, the register must first write 0xAA, otherwise it is invalid.))
 - Other values= Invalid.

18.3.2 LED Control Register LEDCON

F765H	Bit7	Bit6	Bit5	Bit4	Bit3	Bit2	Bit1	Bit0
LEDCON	LED_EN	DUTY1	DUTY0	CC_CA	--	--	CLKSEL1	CLKSEL0
R/W	R/W	R/W	R/W	R/W	R/W	R/W	R/W	R/W
Reset value	0	0	0	0	0	0	0	0

Bit7	LED_EN:	LED enable control bit; 1= LED enable; 0= LEDs are Disable.
Bit6~Bit5	DUTY<1:0>:	Duty cycle selection bit of the LED; 11= 1/4DUTY; 10= 1/5DUTY; 01= 1/6DUTY; 00= 1/8DUTY;
Bit4	CC_CA:	LED drive mode select bit; 1= Co-solar drive mode; 0= Co-negative drive mode.
Bit3~Bit2	--	Reserved, must be 0.
Bit1~Bit0	CLKSEL:	LED clock source F _{LED} selection; 11= LSI; 10= LSI; 01= LSE; 00= Fsys (System Clock).

COM selection description table

DUTY	ICOM0	ICOM1	ICOM2	ICOM3	ICOM4	ICOM5	ICOM6	ICOM7	Effective SEG mouth
11	LED_C0	LED_C1	LED_C2	LED_C3	-	-	-	-	LED_S0-LED_S15
10	LED_C0	LED_C1	LED_C2	LED_C3	LED_C4	-	-	-	LED_S1-LED_S15
01	LED_C0	LED_C1	LED_C2	LED_C3	LED_C4	LED_C5	-	-	LED_S2-LED_S15
00	LED_C0	LED_C1	LED_C2	LED_C3	LED_C4	LED_C5	LED_C6	LED_C7	LED_S4-LED_S15

Note: The ICOM0-ICOM7 in the above table is the output signal of the LED internal COM drive.

LED_C0-LED_C7, LED_S0-LED_S15 is the pin name to which the internal drive signal of the LED is ultimately mapped.

18.3.3 LED Clock Prescale Data Register Low 8 Bit LEDCLKL

F766H	Bit7	Bit6	Bit5	Bit4	Bit3	Bit2	Bit1	Bit0
LEDCLKL	CLK7	CLK6	CLK5	CLK4	CLK3	CLK2	CLK1	CLK0
R/W	R/W	R/W	R/W	R/W	R/W	R/W	R/W	R/W
Reset value	0	0	0	0	0	0	0	0

Bit7~Bit0	CLK<7:0>:	The LED clock divider is 8 bits lower.
-----------	-----------	--

18.3.4 LED Clock Prescale Data Register High 8 Bit LEDCLKH

F767H	Bit7	Bit6	Bit5	Bit4	Bit3	Bit2	Bit1	Bit0
LEDCLKH	CLK15	CLK14	CLK13	CLK12	CLK11	CLK10	CLK9	CLK8
R/W	R/W	R/W	R/W	R/W	R/W	R/W	R/W	R/W
Reset value	0	0	0	0	0	0	0	0

Bit7~Bit0 CLK<15:8>: The LED clock divider is 8 bits high.

Clock frequency of the LED driver: $F_{LED_CLK} = F_{LED} / (CLK<15:0>+1)$.

18.3.5 COM Port Valid Time Selection Register LEDCOMTIME

F768H	Bit7	Bit6	Bit5	Bit4	Bit3	Bit2	Bit1	Bit0
LEDCOMTIME	COMT7	COMT6	COMT5	COMT4	COMT3	COMT2	COMT1	COMT0
R/W	R/W	R/W	R/W	R/W	R/W	R/W	R/W	R/W
Reset value	0	0	0	0	0	0	0	0

Bit7~Bit0 COMT<7:0>: COM port effective time setting.

Note: It is forbidden to set the 0x00;

COM时间 = (COMT<7:0> + 1) * T_{LED_CLK}.

18.3.6 COM Port Enable Control Register LEDCOMEN

F760H	Bit7	Bit6	Bit5	Bit4	Bit3	Bit2	Bit1	Bit0
LEDCOMEN	COMEN7	COMEN6	COMEN5	COMEN4	COMEN3	COMEN2	COMEN1	COMEN0
R/W	R/W	R/W	R/W	R/W	R/W	R/W	R/W	R/W
Reset value	0	0	0	0	0	0	0	0

Bit7~Bit0 COMEN<7:0>: LED_C7-LED_C0 port enable control bit;

1= Enable;

0= Disable.

18.3.7 SEG Port Enable Control Register LEDSEGEN0

F761H	Bit7	Bit6	Bit5	Bit4	Bit3	Bit2	Bit1	Bit0
LEDSEGEN0	SEGEN7	SEGEN6	SEGEN5	SEGEN4	SEGEN3	SEGEN2	SEGEN1	SEGEN0
R/W	R/W	R/W	R/W	R/W	R/W	R/W	R/W	R/W
Reset value	0	0	0	0	0	0	0	0

Bit7~Bit0 BLESSINGS<7:0>: LED_S7-LED_S0 port enable control bit;

1= Enable;

0= Disable.

18.3.8 SEG Port Enable Control Register LEDSEGEN1

F762H	Bit7	Bit6	Bit5	Bit4	Bit3	Bit2	Bit1	Bit0
LEDSEGEN1	SEGEN15	SEGEN14	SEGEN13	SEGEN12	SEGEN11	SEGEN10	SEGEN9	SEGEN8
R/W	R/W	R/W	R/W	R/W	R/W	R/W	R/W	R/W
Reset value	0	0	0	0	0	0	0	0

Bit7~Bit0 BLESSING<15:8>: LED_S15-LED_S8 port enable control bit;
 1= Enable;
 0= Disable.

18.3.9 COM0 Corresponding SEG Data Register LEDC0DATA_n (n=0-1).

	Bit7	Bit6	Bit5	Bit4	Bit3	Bit2	Bit1	Bit0
LEDC0DATA _n	SEG[8n+7]	SEG[8n+6]	SEG[8n+5]	SEG[8n+4]	SEG[8n+3]	SEG[8n+2]	SEG[8n+1]	SEG[8n]
R/W	R/W	R/W	R/W	R/W	R/W	R/W	R/W	R/W
Reset value	0	0	0	0	0	0	0	0

LEDC0DATA0 Address: F740H; LEDC0DATA1 address: F741H.

Bit7~Bit0 SEG<8n+7:8n>: When com0 port is active, SEG[8n+7]-SEG[8n] port data output;
 1= High level;
 0= Low level.

18.3.10 COM1 Corresponding SEG Data Register LEDC1DATA_n (n=0-1).

	Bit7	Bit6	Bit5	Bit4	Bit3	Bit2	Bit1	Bit0
LEDC1DATA _n	SEG[8n+7]	SEG[8n+6]	SEG[8n+5]	SEG[8n+4]	SEG[8n+3]	SEG[8n+2]	SEG[8n+1]	SEG[8n]
R/W	R/W	R/W	R/W	R/W	R/W	R/W	R/W	R/W
Reset value	0	0	0	0	0	0	0	0

LEDC1DATA0 Address: F744H; LEDC1DATA1 Address: F745H.

Bit7~Bit0 SEG<8n+7:8n>: When com1 port is active, SEG[8n+7]-SEG[8n] port data output;
 1= High level;
 0= Low level.

18.3.11 COM2 Corresponding SEG Data Register LEDC2DATA_n (n=0-1).

	Bit7	Bit6	Bit5	Bit4	Bit3	Bit2	Bit1	Bit0
LEDC2DATA _n	SEG[8n+7]	SEG[8n+6]	SEG[8n+5]	SEG[8n+4]	SEG[8n+3]	SEG[8n+2]	SEG[8n+1]	SEG[8n]
R/W	R/W	R/W	R/W	R/W	R/W	R/W	R/W	R/W
Reset value	0	0	0	0	0	0	0	0

LEDC2DATA0 Address: F748H; LEDC2DATA1 Address: F749H.

Bit7~Bit0 SEG<8n+7:8n>: When com2 port is active, SEG[8n+7]-SEG[8n] port data output;
 1= High level;
 0= Low level.

18.3.12 COM3 Corresponding SEG Data Register LEDC3DATA_n (n=0-1).

	Bit7	Bit6	Bit5	Bit4	Bit3	Bit2	Bit1	Bit0
LEDC3DATA _n	SEG[8n+7]	SEG[8n+6]	SEG[8n+5]	SEG[8n+4]	SEG[8n+3]	SEG[8n+2]	SEG[8n+1]	SEG[8n]
R/W	R/W	R/W	R/W	R/W	R/W	R/W	R/W	R/W
Reset value	0	0	0	0	0	0	0	0

LEDC3DATA0 Address: F74CH; LEDC3DATA1 Address: F74DH.

Bit7~Bit0 SEG<8n+7:8n>: When the COM3 port is active, the SEG[8n+7]-SEG[8n] port data output;
 1= High level;
 0= Low level.

18.3.13 COM4 Corresponding SEG Data Register LEDC4DATA_n (n=0-1).

	Bit7	Bit6	Bit5	Bit4	Bit3	Bit2	Bit1	Bit0
LEDC4DATA _n	SEG[8n+7]	SEG[8n+6]	SEG[8n+5]	SEG[8n+4]	SEG[8n+3]	SEG[8n+2]	SEG[8n+1]	SEG[8n]
R/W	R/W	R/W	R/W	R/W	R/W	R/W	R/W	R/W
Reset value	0	0	0	0	0	0	0	0

LEDC4DATA0 Address: F750H; LEDC4DATA1 Address: F751H.

Bit7~Bit0 SEG<8n+7:8n>: When com4 port is active, SEG[8n+7]-SEG[8n] port data output;
 1= High level;
 0= Low level.

18.3.14 COM5 Corresponding SEG Data Register LEDC5DATA_n (n=0-1).

	Bit7	Bit6	Bit5	Bit4	Bit3	Bit2	Bit1	Bit0
LEDC5DATA _n	SEG[8n+7]	SEG[8n+6]	SEG[8n+5]	SEG[8n+4]	SEG[8n+3]	SEG[8n+2]	SEG[8n+1]	SEG[8n]
R/W	R/W	R/W	R/W	R/W	R/W	R/W	R/W	R/W
Reset value	0	0	0	0	0	0	0	0

LEDC5DATA0 Address: F754H; LEDC5DATA1 Address: F755H.

Bit7~Bit0 SEG<8n+7:8n>: When com5 port is active, SEG[8n+7]-SEG[8n] port data output;
 1= High level;
 0= Low level.

18.3.15 COM6 Corresponding SEG Data Register LEDC6DATA_n (n=0-1).

	Bit7	Bit6	Bit5	Bit4	Bit3	Bit2	Bit1	Bit0
LEDC6DATA _n	SEG[8n+7]	SEG[8n+6]	SEG[8n+5]	SEG[8n+4]	SEG[8n+3]	SEG[8n+2]	SEG[8n+1]	SEG[8n]
R/W	R/W	R/W	R/W	R/W	R/W	R/W	R/W	R/W
Reset value	0	0	0	0	0	0	0	0

LEDC6DATA0 Address: F758H; LEDC6DATA1 Address: F759H.

Bit7~Bit0 SEG<8n+7:8n>: When the COM6 port is active, SEG[8n+7]-SEG[8n] port data output;
 1= High level;
 0= Low level.

18.3.16 COM7 Corresponding SEG Data Register LEDC7DATA_n (n=0-1).

	Bit7	Bit6	Bit5	Bit4	Bit3	Bit2	Bit1	Bit0
LEDC7DATA _n	SEG[8n+7]	SEG[8n+6]	SEG[8n+5]	SEG[8n+4]	SEG[8n+3]	SEG[8n+2]	SEG[8n+1]	SEG[8n]
R/W	R/W	R/W	R/W	R/W	R/W	R/W	R/W	R/W
Reset value	0	0	0	0	0	0	0	0

LEDC7DATA0 Address: F75CH; LEDC7DATA1 address: F75DH.

Bit7~Bit0 SEG<8n+7:8n>: When com7 port is active, SEG[8n+7]-SEG[8n] port data output;
 1= High level;
 0= Low level.

18.3.17 P04-P07 Drive Current Control Register LEDSDRP0H

F711H	Bit7	Bit6	Bit5	Bit4	Bit3	Bit2	Bit1	Bit0
LEDSDRP0H	--	--	--	--	DRC3	DRC2	DRC1	DRC0
R/W	R/W	R/W	R/W	R/W	R/W	R/W	R/W	R/W
Reset value	0	0	0	0	1	1	1	1

Bit7~Bit4 -- Reserved, must be 0.

Bit3~Bit0 DRC<3:0>: Pull current drive selection control position (control P04/P05/P06/P07 four ports);

0000= 0mA;	1000= 21.6mA;
0001= 2.7mA;	1001= 24.3mA;
0010= 5.4mA;	1010= 27.0mA;
0011= 8.1mA;	1011= 29.7mA;
0100= 10.9mA;	1100= 32.4mA;
0101= 13.5mA;	1101= 35.1mA;
0110= 16.2mA;	1110= 37.8mA;
0111= 18.9mA;	1111= 40.5mA.

18.3.18 P10-P13 Drive Current Control Register LEDSDRP1L

F712H	Bit7	Bit6	Bit5	Bit4	Bit3	Bit2	Bit1	Bit0
LEDSDRP1L	--	--	--	--	DRC3	DRC2	DRC1	DRC0
R/W	R/W	R/W	R/W	R/W	R/W	R/W	R/W	R/W
Reset value	0	0	0	0	1	1	1	1

Bit7~Bit4 -- Reserved, must be 0.

Bit3~Bit0 DRC<3:0>: Pull current drive select control position (control P10/P11/P12/P13 four ports);

0000= 0mA;	1000= 21.6mA;
0001= 2.7mA;	1001= 24.3mA;
0010= 5.4mA;	1010= 27.0mA;
0011= 8.1mA;	1011= 29.7mA;
0100= 10.9mA;	1100= 32.4mA;
0101= 13.5mA;	1101= 35.1mA;
0110= 16.2mA;	1110= 37.8mA;
0111= 18.9mA;	1111= 40.5mA.

18.3.19 P14-P17 Drive Current Control Register LEDSDRP1H

F713H	Bit7	Bit6	Bit5	Bit4	Bit3	Bit2	Bit1	Bit0
LEDSDRP1H	--	--	--	--	DRC3	DRC2	DRC1	DRC0
R/W	R/W	R/W	R/W	R/W	R/W	R/W	R/W	R/W
Reset value	0	0	0	0	1	1	1	1

Bit7~Bit4 -- Reserved, must be 0.

Bit3~Bit0 DRC<3:0>: Pull current drive select control position (control P14/P15/P16/P17 four ports);

0000=	0mA;	1000=	21.6mA;
0001=	2.7mA;	1001=	24.3mA;
0010=	5.4mA;	1010=	27.0mA;
0011=	8.1mA;	1011=	29.7mA;
0100=	10.9mA;	1100=	32.4mA;
0101=	13.5mA;	1101=	35.1mA;
0110=	16.2mA;	1110=	37.8mA;
0111=	18.9mA;	1111=	40.5mA.

18.3.20 P20-P23 Drive Current Control Register LEDSDRP2L

F714H	Bit7	Bit6	Bit5	Bit4	Bit3	Bit2	Bit1	Bit0
LEDSDRP2L	--	--	--	--	DRC3	DRC2	DRC1	DRC0
R/W	R/W	R/W	R/W	R/W	R/W	R/W	R/W	R/W
Reset value	0	0	0	0	1	1	1	1

Bit7~Bit4 -- Reserved, must be 0.

Bit3~Bit0 DRC<3:0>: Pull current drive select control position (control P20/P21/P22/P23 four ports);

0000=	0mA;	1000=	21.6mA;
0001=	2.7mA;	1001=	24.3mA;
0010=	5.4mA;	1010=	27.0mA;
0011=	8.1mA;	1011=	29.7mA;
0100=	10.9mA;	1100=	32.4mA;
0101=	13.5mA;	1101=	35.1mA;
0110=	16.2mA;	1110=	37.8mA;
0111=	18.9mA;	1111=	40.5mA.

18.3.21 LED Pin Drive Enable Low 8-bit LEDENL

F75EH	Bit7	Bit6	Bit5	Bit4	Bit3	Bit2	Bit1	Bit0
LEDENL	LEDENL7	LEDENL6	LEDENL5	LEDENL4	LEDENL3	LEDENL2	LEDENL1	LEDENL0
R/W	R/W	R/W	R/W	R/W	R/W	R/W	R/W	R/W
Reset value	0	0	0	0	0	0	0	0

- Bit7** **LEDENL7:**
- (LEDMODE==0xAA) dot matrix drive mode LED7 (P07) pin function and drive enable bit;
- 1= Led7 pins of the dot matrix drive function enable;
The pull current drive of the LED7 pins is configured by the LEDSDRP0H register.
- 0= The dot matrix drive function of the LED7 pins is Disabled as a GPIO function;
The current drive of the LED7 pin is the default.
- (LEDMODE!=0xAA) Matrix drive mode SEG7 (P13) / software drive P13 pin current drive enable bit;
- 1= The pull current drive of the P13 pin is configured by the LEDSDRP1L register;
- 0= The pull current drive of the P13 pin is the default.
- Bit6** **LEDENL6:**
- (LEDMODE==0xAA) dot matrix drive mode LED6 (P06) pin function and current drive enable bit;
- 1= Led6 pins are enabled by dot matrix drive function;
The pull current drive at the LED6 pins is configured by the LEDSDRP0H register.
- 0= The dot matrix drive function of the LED6 pins is Disabled as a GPIO function;
The pull current drive of the LED6 pin is the default value.
- (LEDMODE!=0xAA) Matrix drive mode SEG6 (P12) / software drive P12 pin current drive enable bit;
- 1= The pull current drive of the P12 pin is configured by the LEDSDRP1L register;
- 0= The pull current drive of the P12 pin is the default value.
- Bit5** **LEDENL5:**
- (LEDMODE==0xAA) dot matrix drive mode LED5 (P05) pin function and current drive enable bit;
- 1= Led5 pins of the dot matrix drive function enable;
The pull current drive at the LED5 pins is configured by the LEDSDRP0H register.
- 0= The dot matrix drive function of the LED5 pins is Disabled as a GPIO function;
The current drive of the LED5 pin is the default.
- (LEDMODE!=0xAA) Matrix drive mode SEG5 (P11) / software drive P11 pin current drive enable bit;
- 1= The pull current drive of the P11 pin is configured by the LEDSDRP1L register;
- 0= The pull current drive of the P11 pin is the default.
- Bit4** **LEDENL4:**
- (LEDMODE==0xAA) dot matrix drive mode LED4 (P04) pin function and current drive enable bit;
- 1= Led 4 pins of the dot matrix drive function enable;
The pull current drive at the LED4 pins is configured by the LEDSDRP0H register.
- 0= The dot matrix drive function of the LED4 pins is Disabled as a GPIO function;
The current drive of the LED4 pin is the default value.
- (LEDMODE!=0xAA) Matrix drive mode SEG4 (P10) / software drive P10 pin current drive enable bit;
- 1= The pull current drive of the P10 pin is configured by the LEDSDRP1L register;
- 0= The pull current drive of the P10 pin is the default value.

Bit3	LEDENL3:	<p>(LEDMODE==0xAA) dot matrix drive mode LED3 (P03) pin function and current drive enable bit;</p> <p>1= Led3 pins of the dot matrix drive function enable; The pull current drive of the LED3 pins is configured by the LEDSDRP0L register.</p> <p>0= The dot matrix drive function of the LED3 pins is Disabled as a GPIO function; The pull current drive of the LED3 pins is the default value.</p> <p>(LEDMODE!=0xAA) Matrix drive mode SEG3 (P07) / software drive P07 pin current drive enable bit;</p> <p>1= The pull current drive of the P07 pin is configured by the LEDSDRP0H register;</p> <p>0= The pull current drive of the P07 pin is the default value.</p>
Bit2	LEDENL2:	<p>(LEDMODE==0xAA) dot matrix drive mode LED2 (P02) pin function and current drive enable bit;</p> <p>1= Led2 pins are enabled by the dot matrix drive function; The pull current drive at the LED2 pins is configured by the LEDSDRP0L register.</p> <p>0= The dot matrix drive function of the LED2 pin is Disabled, as a GPIO function; The current drive of the LED2 pin is the default value.</p> <p>(LEDMODE!=0xAA) Matrix drive mode SEG2 (P06) / software drive P06 pin current drive enable bit;</p> <p>1= The pull current drive of the P06 pin is configured by the LEDSDRP0H register;</p> <p>0= The pull current drive of the P06 pin is the default value.</p>
Bit1	LEDENL1:	<p>(LEDMODE==0xAA) dot matrix drive mode LED1 (P01) pin function and current drive enable bit;</p> <p>1= Led 1 pins of the dot matrix drive function enable; The pull current drive at the LED1 pin is configured by the LEDSDRP0L register.</p> <p>0= The dot matrix drive function of the LED1 pin is Disabled as a GPIO function; The pull current drive of the LED1 pin is the default value.</p> <p>(LEDMODE!=0xAA) Matrix drive mode SEG1 (P05) / software drive P05 pin current drive enable bit;</p> <p>1= The pull current drive of the P05 pin is configured by the LEDSDRP0H register;</p> <p>0= The pull current drive of the P05 pin is the default value.</p>
Bit0	LEDENL0:	<p>(LEDMODE==0xAA) dot matrix drive mode LED0 (P00) pin function and current drive enable bit;</p> <p>1= LED0 pins are enabled by dot matrix drive function; The pull current drive of the LED0 pins is configured by the LEDSDRP0L register.</p> <p>0= The dot matrix drive function of the LED0 pin is Disabled as a GPIO function; The pull current drive of the LED0 pin is the default value.</p> <p>(LEDMODE!=0xAA) Matrix drive mode SEG0 (P04) / software drive P04 pin current drive enable bit;</p> <p>1= The pull current drive of the P04 pin is configured by the LEDSDRP0H register;</p> <p>0= The pull current drive of the P04 pin is the default value.</p>

18.3.22 LED Pin Drive Enable High 8-bit LEDENH

F75FH	Bit7	Bit6	Bit5	Bit4	Bit3	Bit2	Bit1	Bit0
LEDENH	LEDENH7	LEDENH6	LEDENH5	LEDENH4	LEDENH3	LEDENH2	LEDENH1	LEDENH0
R/W	R/W	R/W	R/W	R/W	R/W	R/W	R/W	R/W
Reset value	0	0	0	0	0	0	0	0

- Bit7 LEDENH7:
- (LEDMODE==0xAA);
- 1= Invalid;
- 0= Invalid.
- (LEDMODE!=0xAA) Matrix drive mode SEG15 (P23) / software drive P23 pin current drive enable bit;
- 1= The pull current drive of the P23 pin is configured by the LEDSDRP2L register;
- 0= The pull current drive of the P23 pin is the default.
- Bit6 LEDENH6:
- (LEDMODE==0xAA);
- 1= Invalid;
- 0= Invalid.
- (LEDMODE!=0xAA) Matrix drive mode SEG14 (P22) / software drive P22 pin current drive enable bit;
- 1= The pull current drive of the P22 pin is configured by the LEDSDRP2L register;
- 0= The pull current drive of the P22 pin is the default.
- Bit5 LEDENH5:
- (LEDMODE==0xAA);
- 1= Invalid;
- 0= Invalid.
- (LEDMODE!=0xAA) Matrix drive mode SEG13 (P21) / software drive P21 pin current drive enable bit;
- 1= The pull current drive of the P21 pin is configured by the LEDSDRP2L register;
- 0= The pull current drive of the P21 pin is the default value.
- Bit4 LEDENH4:
- (LEDMODE==0xAA);
- 1= Invalid;
- 0= Invalid.
- (LEDMODE!=0xAA) Matrix drive mode SEG12 (P20) / software drive P20 pin current drive enable bit;
- 1= The pull current drive of the P20 pin is configured by the LEDSDRP2L register;
- 0= The pull current drive of the P20 pin is the default.
- Bit3 LEDENH3:
- (LEDMODE==0xAA);
- 1= Invalid;
- 0= Invalid.
- (LEDMODE!=0xAA) Matrix drive mode SEG11 (P17) / software drive P17 pin current drive enable bit;
- 1= The pull current drive of the P17 pin is configured by the LEDSDRP1H register;
- 0= The pull current drive of the P17 pin is the default value.
- Bit2 LEDENH2:
- (LEDMODE==0xAA);
- 1= Invalid;
- 0= Invalid.

- (LEDMODE!=0xAA) Matrix drive mode SEG10 (P16) / software drive P16 pin current drive enable bit;
- 1= The pull current drive of the P16 pin is configured by the LEDSDRP1H register;
0= The pull current drive of the P16 pin is the default value.
- Bit1 LEDENH1:
- (LEDMODE==0xAA);
- 1= Invalid;
0= Invalid.
- (LEDMODE!=0xAA) Matrix drive mode SEG9 (P15) / software drive P15 pin current drive enable bit;
- 1= The pull current drive of the P15 pins is configured by the LEDSDRP1H register;
0= The pull current drive of the P15 pin is the default value.
- Bit0 LEDENH0:
- (LEDMODE==0xAA) dot matrix drive mode LED8 (P10) pin function enable bit (pin current drive is the default);
- 1= Led8 pins are enabled by dot matrix drive function;
0= The dot matrix drive function of the LED8 pins is Disabled as a GPIO function.
- (LEDMODE!=0xAA) Matrix drive mode SEG8 (P14) / software drive P14 pin current drive enable bit;
- 1= The pull current drive of the P14 pin is configured by the LEDSDRP1H register;
0= The pull current drive of the P14 pin is the default.

18.3.23 COM Port Sink Current Selection Register P0DR

F00CH	Bit7	Bit6	Bit5	Bit4	Bit3	Bit2	Bit1	Bit0
P0DR	P0DR7	P0DR6	P0DR5	P0DR4	P0DR3	P0DR2	P0DR1	P0DR0
R/W	R/W	R/W	R/W	R/W	R/W	R/W	R/W	R/W
Reset value	0	0	0	0	0	0	0	0

Bit7	P0DR7: P07 drive current selection; 1= 150mA; 0= 50mA.
Bit6	P0DR6: P06 drive current selection; 1= 150mA; 0= 50mA.
Bit5	P0DR5: P05 drive current selection; 1= 150mA; 0= 50mA.
Bit4	P0DR4: P04 drive current selection; 1= 150mA; 0= 50mA.
Bit3	P0DR3: P03 drive current selection; 1= 150mA; 0= 50mA.
Bit2	P0DR2: P02 drive current selection; 1= 150mA; 0= 50mA.
Bit1	P0DR1: P01 drive current selection; 1= 150mA; 0= 50mA.
Bit0	P0DR0: P00 drive current selection; 1= 150mA; 0= 50mA.

18.4 LED Driver Output Waveform

According to the relevant configuration registers of the LED driver, the corresponding LED driver output waveform can be set.

The LED is configured with 1/4DUTY, co-negative drive mode, and the waveform is shown in the following figure:

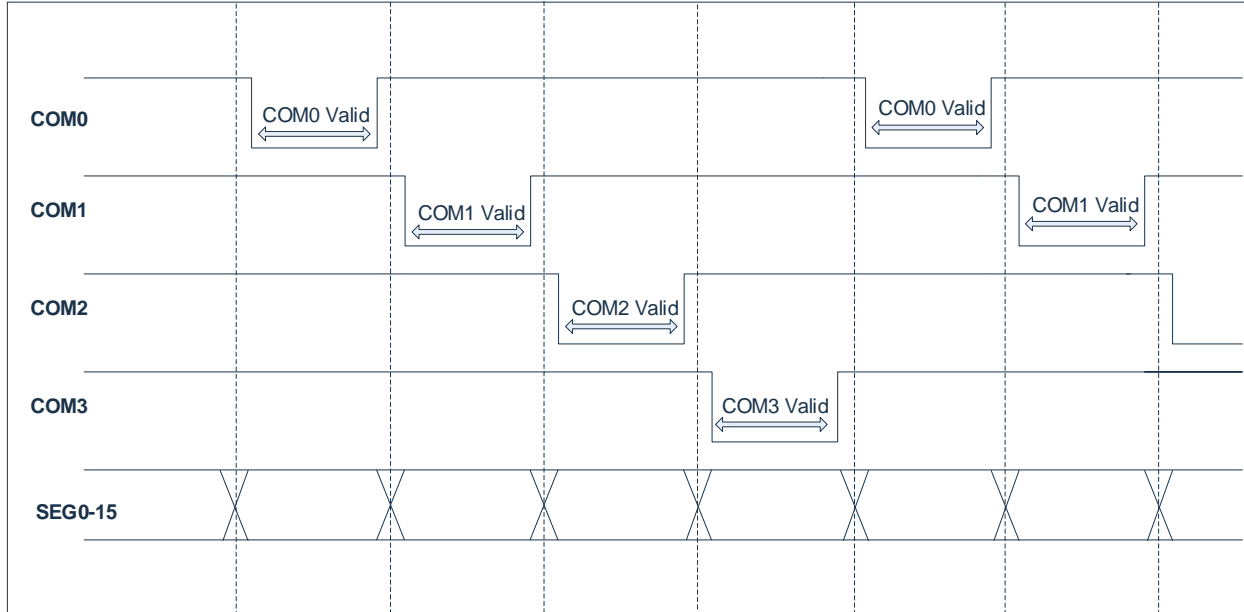

19. Hardware LED Dot Matrix Driver

19.1 Overview

LED dot matrix drive is to configure LED0 ~ LED8 port, so as to drive multiple LED lights, convenient for users to drive LED dot matrix.

19.2 Characteristic

LED dot matrix drive mode features:

- ◆ Supports up to 64 led drivers, configurable to select dot matrix 4x4, 5x5, 6x6, 6x7, 7x7, 7x8, 8x8.
- ◆ Each lamp supports two on-time options, each with a 16-bit timing setting.
- ◆ Each lamp display data is individually selectable.
- ◆ The LED dot matrix driver supports cyclic scan mode and interrupt scan mode.
- ◆ LED dot matrix drive clock source Fsys, LSI, LSE three optional.
- ◆ The LED dot matrix driver clock source supports 16-bit crossover.
- ◆ LED dot matrix drive mode LED0-LED8 pin enable is optional.
- ◆ LED0 ~ LED7 current 16 steps are available, the maximum current up to 40mA ($V_{OH} = 3.5V@VDD = 5V$).
- ◆ The 64-lamp dot matrix address is unique, see the lattice description below for entering switch lamp information.

19.3 Feature Description

LED dot matrix is scanned by 8 * 8 dot matrix dual lamp mode, that is, two lights at a time (common cathode), corresponding to LED0 ~ LED8 port, up to 8x8 = 64 lights can be configured to drive. Configure the lighting situation of the corresponding address (1 means light, 0 means no light), the hardware will resolve the light address and the current scan address, and automatically complete the output control of the corresponding IO port. Can be configured 4x4, 5x5, 6x6, 6x7, 7x7, 7x8, 8x8, different size dot matrix (corresponding lamp address unchanged).

The 8*8 dot matrix is shown in the following figure (the blue light in the figure is a separate scanning lamp):

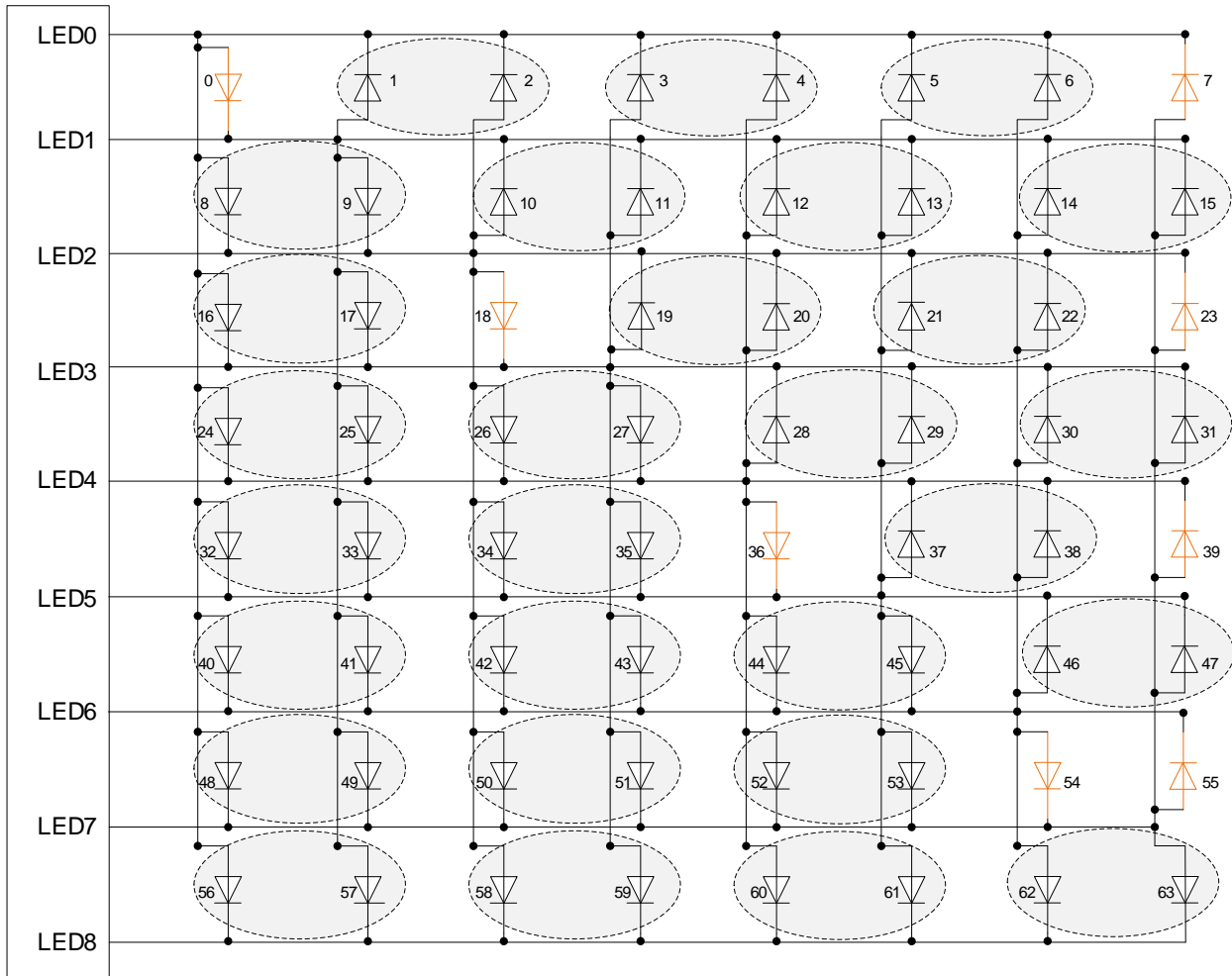

The 7*8 dot matrix is shown in the following figure:

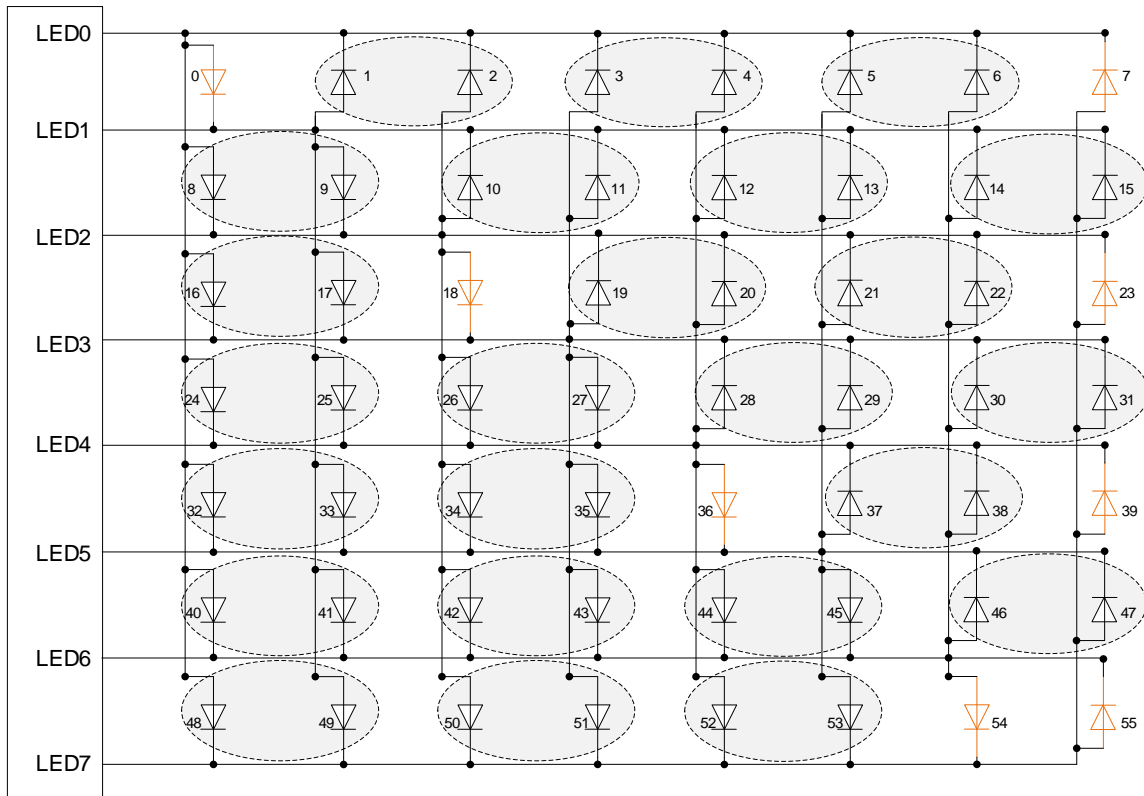

The 7*7 dot matrix is shown in the following figure:

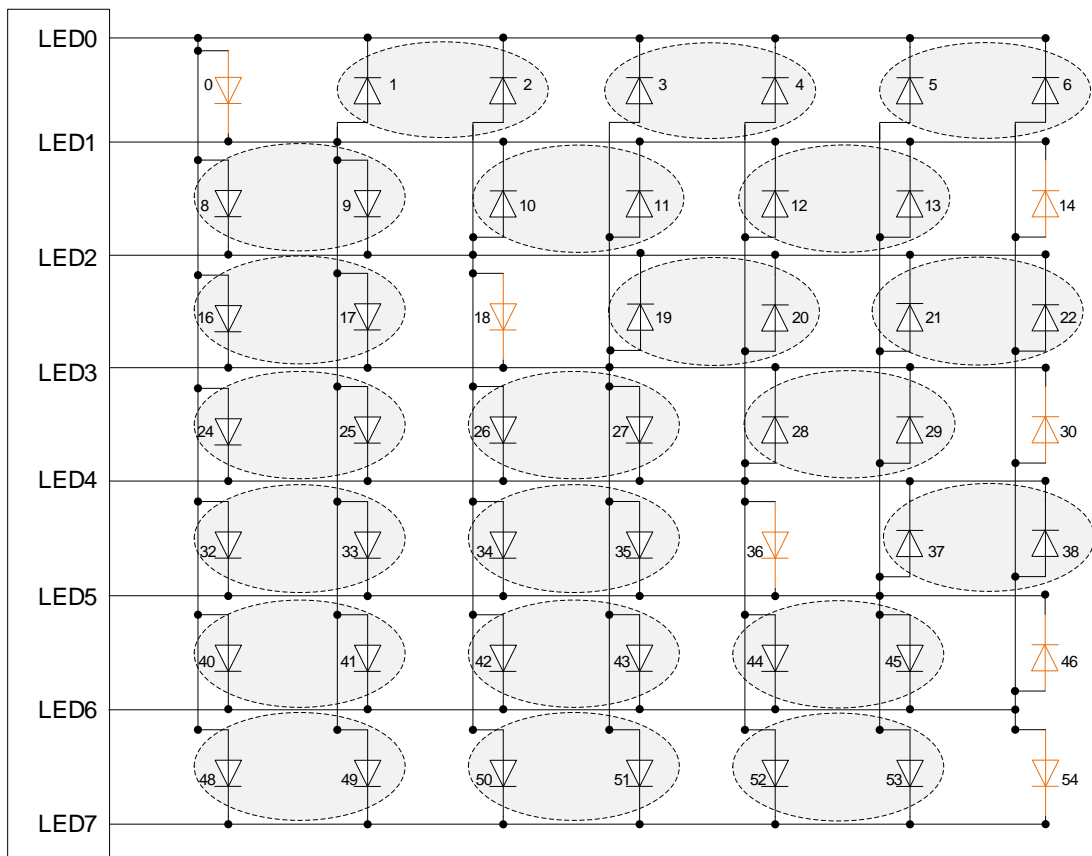

The 6*7 dot matrix is shown in the following figure:

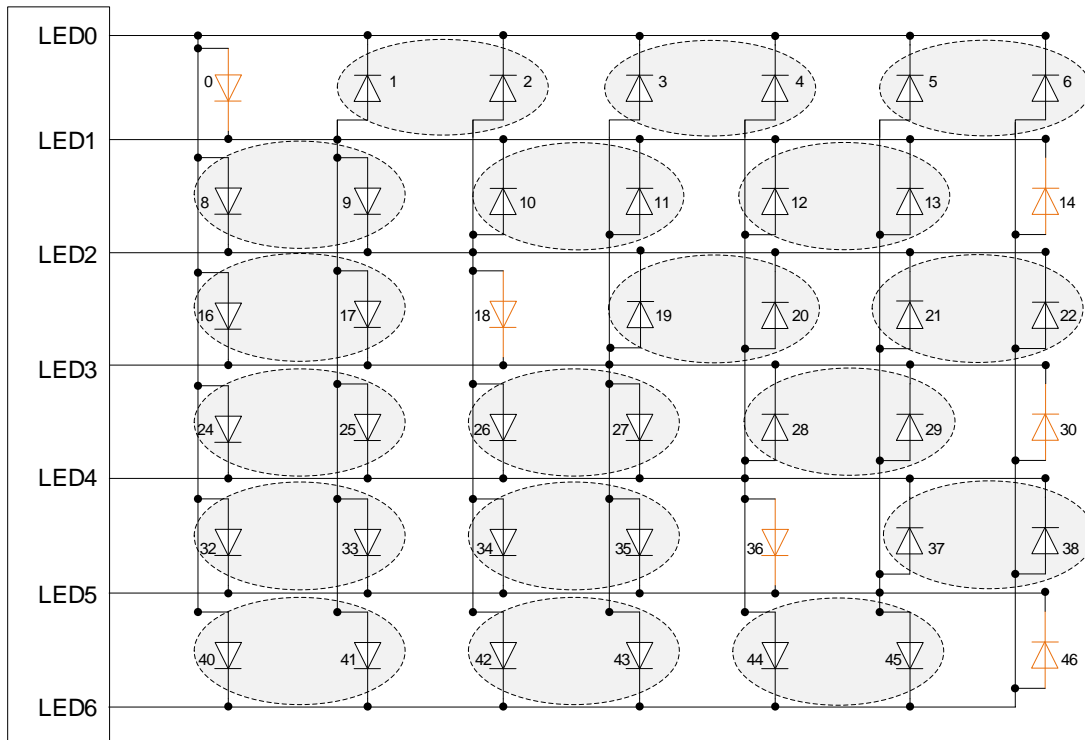

The 6*6 dot matrix is shown in the following figure:

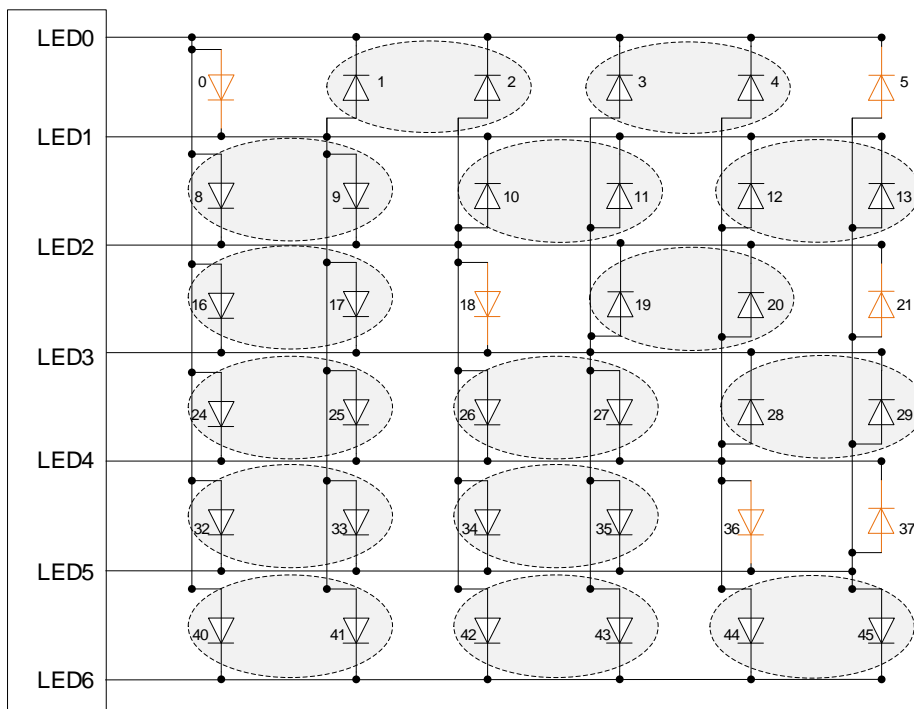

The 5*5 dot matrix is shown in the following figure:

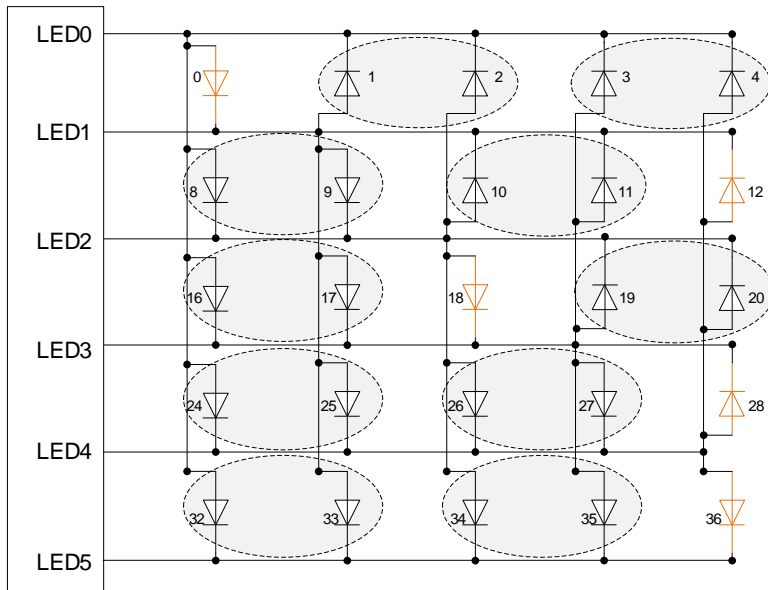

The 4*4 dot matrix is shown in the following figure:

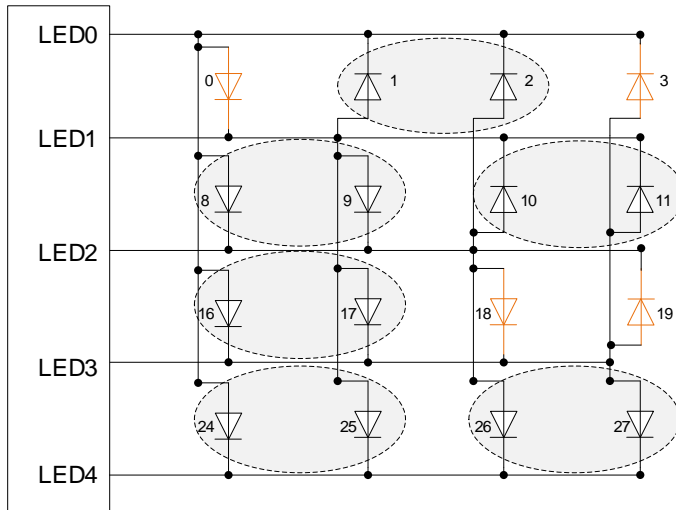

Taking the light 0, 1, and 2 as an example, the detailed digital output interface control timing is shown in the following figure:

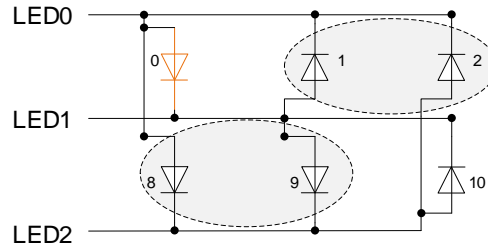

Schematic diagram of two lights

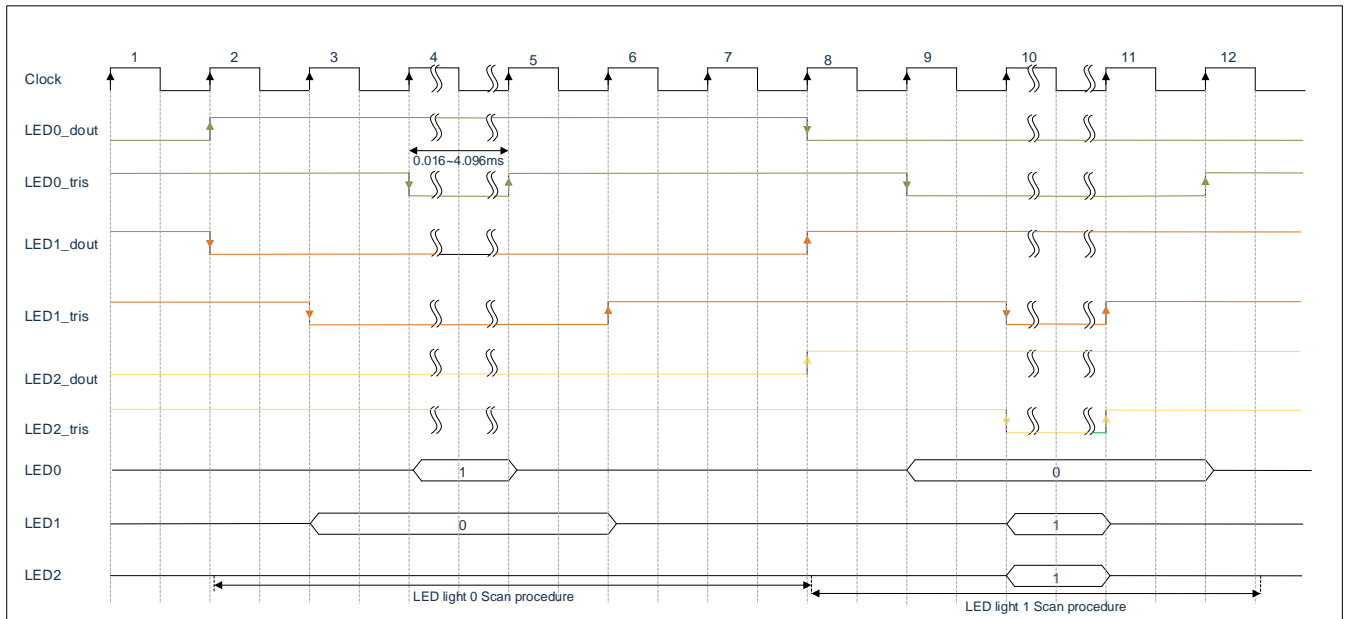

Digital output timing chart

19.4 Related Registers

19.4.1 LED Drive Mode Select Register LEDMODE

F7690\CLOCK	Bit7	Bit6	Bit5	Bit4	Bit3	Bit2	Bit1	Bit0
LEDMODE	LEDMODE7	LEDMODE6	LEDMODE5	LEDMODE4	LEDMODE3	LEDMODE2	LEDMODE1	LEDMODE0
R/W	R/W	R/W	R/W	R/W	R/W	R/W	R/W	R/W
Reset value	0	0	0	0	0	0	0	0

- Bit7~Bit0 LEDMODE<7:0>: LED drive mode selection register;
- 0x55= The LED matrix drive mode is valid, and the relevant registers are in effect;
(Before configuring the LED matrix drive mode, the register must first write 0x55, otherwise it is invalid.))
 - 0xAA= The LED dot matrix drive mode is valid, and the relevant registers are effective;
(Before configuring led dot matrix drive mode, the register must first write 0xAA, otherwise it is invalid.))
 - Other values= Invalid.

19.4.2 LED Dot Matrix Drive Controller LEDCON1

F765H	Bit7	Bit6	Bit5	Bit4	Bit3	Bit2	Bit1	Bit0
LEDCON1	SCAN_START	DUTY2	DUTY1	DUTY0	SCAN_MODE	--	CLKSEL1	CLKSEL0
R/W	R/W	R/W	R/W	R/W	R/W	R/W	R/W	R/W
Reset value	0	0	0	0	0	0	0	0

- Bit7 SCAN_START: LED dot matrix drive scan on bit;
- 1= LED scan on;
 - 0= LED scanning stops.
- Bit6~Bit4 DUTY<2:0>: LED dot matrix selection;
- 000= Invalid;
 - 001= 4*4 dot matrix;
 - 010= 5*5 dot matrix;
 - 011= 6*6 dot matrix;
 - 100= 6*7 dot matrix;
 - 101= 7*7 dot matrix;
 - 110= 7*8 dot matrix;
 - 111= 8*8 dot matrix.
- Bit3 SCAN_MODE: LED scan mode configuration;
- 1= LED dot matrix drive cyclic scanning mode;
 - 0= LED dot matrix drives interrupt scan mode. (When you select the interrupt scan mode, complete a scan, the hardware clears SCAN_START bits, the interrupt flag position is 1, and the software rewrites the SCAN_START to 1, and then re-scans.))
- Bit2 -- Reserved, must be 0.
- Bit1~Bit0 CLKSEL: LED dot matrix drives clock source selection
- 11= LSI;
 - 10= LSI;
 - 01= LSE;
 - 00= Fsys (System Clock).

19.4.3 LED Dot Matrix Drive Clock Prescale Register Low 8 Bit LEDCLKL1

F766H	Bit7	Bit6	Bit5	Bit4	Bit3	Bit2	Bit1	Bit0
LEDCLKL1	CLK7	CLK6	CLK5	CLK4	CLK3	CLK2	CLK1	CLK0
R/W	R/W	R/W	R/W	R/W	R/W	R/W	R/W	R/W
Reset value	0	0	0	0	0	0	0	0

Bit7~Bit0 CLK<7:0>: The LED dot matrix drives clock lower 8 bits.

19.4.4 LED Dot Matrix Drive Clock Prescale Register High 8 Bits LEDCLKH1

F767H	Bit7	Bit6	Bit5	Bit4	Bit3	Bit2	Bit1	Bit0
LEDCLKH1	CLK15	CLK14	CLK13	CLK12	CLK11	CLK10	CLK9	CLK8
R/W	R/W	R/W	R/W	R/W	R/W	R/W	R/W	R/W
Reset value	0	0	0	0	0	0	0	0

Bit7~Bit0 CLK<15:8>: The LED dot matrix drive clock higher 8 bits.

Clock frequency of the LED dot matrix driver: $F_{LED_CLK} = F_{LED} / (CLK<15:0>+1)$.

19.4.5 LED Dot Matrix Drive First Stage Configuration Register Higher 8 Bits scan1WH

F761H	Bit7	Bit6	Bit5	Bit4	Bit3	Bit2	Bit1	Bit0
SCAN1WH	SCAN1WH7	SCAN1WH6	SCAN1WH5	SCAN1WH4	SCAN1WH3	SCAN1WH2	SCAN1WH1	SCAN1WH0
R/W	R/W	R/W	R/W	R/W	R/W	R/W	R/W	R/W
Reset value	0	0	0	0	0	0	0	0

Bit7~Bit0 SCAN1WH<7:0>: LED dot matrix drive mode, the first stage of the lamp lighting cycle configuration register is 8 bits high.

19.4.6 LED Dot Matrix Drive First Stage Configuration Register Low 8 Bits SCAN1WL

F762H	Bit7	Bit6	Bit5	Bit4	Bit3	Bit2	Bit1	Bit0
SCAN1WL	SCAN1WL7	SCAN1WL6	SCAN1WL5	SCAN1WL4	SCAN1WL3	SCAN1WL2	SCAN1WL1	SCAN1WL0
R/W	R/W	R/W	R/W	R/W	R/W	R/W	R/W	R/W
Reset value	0	0	0	0	0	0	0	0

(LEDMODE=0xAA, change register takes effect.))

Bit7~Bit0 SCAN1WL<7:0>: LED dot matrix drive mode, the first stage of the light lighting cycle configuration register is 8 bits lower.

Period1 = ((SCAN1WH[7:0], SCAN1WL[7:0])+1) * T_LEDCLK

19.4.7 LED Dot Matrix Drives Second Stage Configuration Register High 8 Bits scan2WH

F763H	Bit7	Bit6	Bit5	Bit4	Bit3	Bit2	Bit1	Bit0
SCAN2WH	SCAN2WH7	SCAN2WH6	SCAN2WH5	SCAN2WH4	SCAN2WH3	SCAN2WH2	SCAN2WH1	SCAN2WH0
R/W	R/W	R/W	R/W	R/W	R/W	R/W	R/W	R/W
Reset value	0	0	0	0	0	0	0	0

Bit7~Bit0 SCAN2WH<7:0>: LED dot matrix drive mode, the second stage of the light lighting cycle configuration register is 8 bits high.

19.4.8 LED Dot Matrix Drive Second Stage Configuration Register Low 8 Bits SCAN2WL

F764H	Bit7	Bit6	Bit5	Bit4	Bit3	Bit2	Bit1	Bit0
SCAN2WL	SCAN2WL7	SCAN2WL6	SCAN2WL5	SCAN2WL4	SCAN2WL3	SCAN2WL2	SCAN2WL1	SCAN2WL0
R/W	R/W	R/W	R/W	R/W	R/W	R/W	R/W	R/W
Reset value	0	0	0	0	0	0	0	0

Bit7~Bit0 SCAN2WL<7:0>: LED dot matrix drive mode, the second stage of the lamp lighting cycle configuration register is 8 bits lower.

Period2 = ((SCAN2WH [7:0], SCAN2WL [7:0])+1) * T_LEDCLK

19.4.9 LED Dot Matrix Drive Display Data Register LEDnDATA (n=0-7).

	Bit7	Bit6	Bit5	Bit4	Bit3	Bit2	Bit1	Bit0
LEDnDATA	LEDnDATA7	LEDnDATA6	LEDnDATA5	LEDnDATA4	LEDnDATA3	LEDnDATA2	LEDnDATA1	LEDnDATA0
R/W	R/W	R/W	R/W	R/W	R/W	R/W	R/W	R/W
Reset value	0	0	0	0	0	0	0	0

LED0DATA Address: F740H; LED1DATA Address: F741H; LED2DATA Address: F744H; LED3DATA Address: F745H;
LED4DATA Address: F748H; LED5DATA Address: F749H; LED6DATA Address: F74CH; LED7DATA Address: F74DH;

Bit7~Bit0 LEDnDATA<7:0>: LED dot matrix drive mode, dot matrix display data configuration register;
1= LED dot matrix drive mode, the LED of the corresponding coordinates on the dot matrix is lit;
0= LED dot matrix drive mode, the LED corresponding to the coordinates on the dot matrix is not lit.

Dot matrix drive mode corresponding to LED display data configuration:

	Bit7	Bit6	Bit5	Bit4	Bit3	Bit2	Bit1	Bit0
LED0DATA	Led7	Led6	Led5	Led4	Led3	Led2	Led1	Led0
LED1DATA	Led15	Led14	Led13	Led12	Led11	Led10	Led9	Led8
LED2DATA	Led23	Led22	Led21	Led20	Led19	Led18	Led17	Led16
LED3DATA	Led31	Led30	Led29	Led28	Led27	Led26	Led25	Led24
LED4DATA	Led39	Led38	Led37	Led36	Led35	Led34	Led33	Led32
LED5DATA	Led47	Led46	Led45	Led44	Led43	Led42	Led41	Led40
LED6DATA	Led55	Led54	Led53	Led52	Led51	Led50	Led49	Led48
LED7DATA	Led63	Led62	Led61	Led60	Led59	Led58	Led57	Led56

Note: Led0-Led63 corresponding 64 LED coordinate positions of 8*8 dot matrix.

19.4.10 LED Dot Matrix Drive Cycle Select Register LEDnSEL (n=0-7).

	Bit7	Bit6	Bit5	Bit4	Bit3	Bit2	Bit1	Bit0
LEDnSEL	LEDnSEL7	LEDnSEL6	LEDnSEL5	LEDnSEL4	LEDnSEL3	LEDnSEL2	LEDnSEL1	LEDnSEL0
R/W	R/W	R/W	R/W	R/W	R/W	R/W	R/W	R/W
Reset value	0	0	0	0	0	0	0	0

LED0SEL Address:F750H; LED1SEL Address:F751H; LED2SEL Address:F754H; LED3SEL Address:F755H;
 LED4SEL Address:F758H; LED5SEL Address:F759H; LED6SEL Address:F75CH; LED7SEL Address:F75DH;

Bit7~Bit0 LEDnSEL<7:0>: LED dot matrix drive mode, dot matrix display cycle configuration register;
 1= LED dot matrix drive mode, the second period of the LED display period corresponding to the coordinates on the dot matrix is selected;
 0= LED dot matrix drive mode, the first period of the LED display period corresponding to the coordinates on the dot matrix is selected.

Dot matrix drive mode corresponding to LED display cycle configuration:

	Bit7	Bit6	Bit5	Bit4	Bit3	Bit2	Bit1	Bit0
LED0SEL0	Led7	Led6	Led5	Led4	Led3	Led2	Led1	Led0
LED1SEL1	Led15	Led14	Led13	Led12	Led11	Led10	Led9	Led8
LED2SEL2	Led23	Led22	Led21	Led20	Led19	Led18	Led17	Led16
LED3SEL3	Led31	Led30	Led29	Led28	Led27	Led26	Led25	Led24
LED4SEL4	Led39	Led38	Led37	Led36	Led35	Led34	Led33	Led32
LED5SEL5	Led47	Led46	Led45	Led44	Led43	Led42	Led41	Led40
LED6SEL6	Led55	Led54	Led53	Led52	Led51	Led50	Led49	Led48
LED7SEL7	Led63	Led62	Led61	Led60	Led59	Led58	Led57	Led56

Note: Led0-Led63 corresponding 64 LED coordinate positions of 8*8 dot matrix.

19.4.11 P00-P03 Drive Current Control Register LEDSDRP0L

F710 H	Bit7	Bit6	Bit5	Bit4	Bit3	Bit2	Bit1	Bit0
LEDSDRP0L	--	--	--	--	DRC3	DRC2	DRC1	DRC0
R/W	R/W	R/W	R/W	R/W	R/W	R/W	R/W	R/W
Reset value	0	0	0	0	1	1	1	1

Bit7~Bit4 -- Reserved, must be 0.

Bit3~Bit0 DRC<3:0>: Pull current drive select control position (control P00/P01/P02/P03 four ports);
 0000= 0mA; 1000= 21.6mA;
 0001= 2.7mA; 1001= 24.3mA;
 0010= 5.4mA; 1010= 27.0mA;
 0011= 8.1mA; 1011= 29.7mA;
 0100= 10.9mA; 1100= 32.4mA;
 0101= 13.5mA; 1101= 35.1mA;
 0110= 16.2mA; 1110= 37.8mA;
 0111= 18.9mA; 1111= 40.5mA.

19.4.12 P04-P07 Drive Current Control Register LEDSDRP0H

F711H	Bit7	Bit6	Bit5	Bit4	Bit3	Bit2	Bit1	Bit0
LEDSDRP0H	--	--	--	--	DRC3	DRC2	DRC1	DRC0
R/W	R/W	R/W	R/W	R/W	R/W	R/W	R/W	R/W
Reset value	0	0	0	0	1	1	1	1

Bit7~Bit4 -- Reserved, must be 0.

Bit3~Bit0 DRC<3:0>: Pull current drive select control position (control P04/P05/P06/P07 four ports);

0000=	0mA;	1000=	21.6mA;
0001=	2.7mA;	1001=	24.3mA;
0010=	5.4mA;	1010=	27.0mA;
0011=	8.1mA;	1011=	29.7mA;
0100=	10.9mA;	1100=	32.4mA;
0101=	13.5mA;	1101=	35.1mA;
0110=	16.2mA;	1110=	37.8mA;
0111=	18.9mA;	1111=	40.5mA.

19.4.13 LED Pin Drive Enable Low 8-bit LEDENL

F75EH	Bit7	Bit6	Bit5	Bit4	Bit3	Bit2	Bit1	Bit0
LEDENL	LEDENL7	LEDENL6	LEDENL5	LEDENL4	LEDENL3	LEDENL2	LEDENL1	LEDENL0
R/W	R/W	R/W	R/W	R/W	R/W	R/W	R/W	R/W
Reset value	0	0	0	0	0	0	0	0

- Bit7 LEDENL7:
- (LEDMODE==0xAA) dot matrix drive mode LED7 (P07) pin function and drive enable bit;
 - 1= Led7 pins of the dot matrix drive function enable;
The pull current drive of the LED7 pins is configured by the LEDSDRP0H register.
 - 0= The dot matrix drive function of the LED7 pins is Disabled as a GPIO function;
The current drive of the LED7 pin is the default.
 - (LEDMODE!=0xAA) Matrix drive mode SEG7 (P13) / software drive P13 pin current drive enable bit;
 - 1= The pull current drive of the P13 pin is configured by the LEDSDRP1L register;
 - 0= The pull current drive of the P13 pin is the default.
- Bit6 LEDENL6:
- (LEDMODE==0xAA) dot matrix drive mode LED6 (P06) pin function and current drive enable bit;
 - 1= Led6 pins are enabled by dot matrix drive function;
The pull current drive at the LED6 pins is configured by the LEDSDRP0H register.
 - 0= The dot matrix drive function of the LED6 pins is Disabled as a GPIO function;
The pull current drive of the LED6 pin is the default value.
 - (LEDMODE!=0xAA) Matrix drive mode SEG6 (P12) / software drive P12 pin current drive enable bit;
 - 1= The pull current drive of the P12 pin is configured by the LEDSDRP1L register;
 - 0= The pull current drive of the P12 pin is the default value.
- Bit5 LEDENL5:
- (LEDMODE==0xAA) dot matrix drive mode LED5 (P05) pin function and current drive enable bit;
 - 1= Led5 pins of the dot matrix drive function enable;
The pull current drive at the LED5 pins is configured by the LEDSDRP0H register.
 - 0= The dot matrix drive function of the LED5 pins is Disabled as a GPIO function;

		<p>The current drive of the LED5 pin is the default. (LEDMODE!=0xAA) Matrix drive mode SEG5 (P11) / software drive P11 pin current drive enable bit;</p> <p>1= The pull current drive of the P11 pin is configured by the LEDSDRP1L register; 0= The pull current drive of the P11 pin is the default.</p>
Bit4	LEDENL4:	<p>(LEDMODE==0xAA) dot matrix drive mode LED4 (P04) pin function and current drive enable bit;</p> <p>1= Led 4 pins of the dot matrix drive function enable; The pull current drive at the LED4 pins is configured by the LEDSDRP0H register.</p> <p>0= The dot matrix drive function of the LED4 pins is Disabled as a GPIO function; The current drive of the LED4 pin is the default value. (LEDMODE!=0xAA) Matrix drive mode SEG4 (P10) / software drive P10 pin current drive enable bit;</p> <p>1= The pull current drive of the P10 pin is configured by the LEDSDRP1L register; 0= The pull current drive of the P10 pin is the default value.</p>
Bit3	LEDENL3:	<p>(LEDMODE==0xAA) dot matrix drive mode LED3 (P03) pin function and current drive enable bit;</p> <p>1= Led3 pins of the dot matrix drive function enable; The pull current drive of the LED3 pins is configured by the LEDSDRP0L register.</p> <p>0= The dot matrix drive function of the LED3 pins is Disabled as a GPIO function; The pull current drive of the LED3 pins is the default value. (LEDMODE!=0xAA) Matrix drive mode SEG3 (P07) / software drive P07 pin current drive enable bit;</p> <p>1= The pull current drive of the P07 pin is configured by the LEDSDRP0H register; 0= The pull current drive of the P07 pin is the default value.</p>
Bit2	LEDENL2:	<p>(LEDMODE==0xAA) dot matrix drive mode LED2 (P02) pin function and current drive enable bit;</p> <p>1= Led2 pins are enabled by the dot matrix drive function; The pull current drive at the LED2 pins is configured by the LEDSDRP0L register.</p> <p>0= The dot matrix drive function of the LED2 pin is Disabled, as a GPIO function; The current drive of the LED2 pin is the default value. (LEDMODE!=0xAA) Matrix drive mode SEG2 (P06) / software drive P06 pin current drive enable bit;</p> <p>1= The pull current drive of the P06 pin is configured by the LEDSDRP0H register; 0= The pull current drive of the P06 pin is the default value.</p>
Bit1	LEDENL1:	<p>(LEDMODE==0xAA) dot matrix drive mode LED1 (P01) pin function and current drive enable bit;</p> <p>1= Led 1 pins of the dot matrix drive function enable; The pull current drive at the LED1 pin is configured by the LEDSDRP0L register.</p> <p>0= The dot matrix drive function of the LED1 pin is Disabled as a GPIO function; The pull current drive of the LED1 pin is the default value. (LEDMODE!=0xAA) Matrix drive mode SEG1 (P05) / software drive P05 pin current drive enable bit;</p> <p>1= The pull current drive of the P05 pin is configured by the LEDSDRP0H register; 0= The pull current drive of the P05 pin is the default value.</p>
Bit0	LEDENL0:	<p>(LEDMODE==0xAA) dot matrix drive mode LED0 (P00) pin function and current drive</p>

- enable bit;
- 1= LED0 pins are enabled by dot matrix drive function;
The pull current drive of the LED0 pins is configured by the LEDSDRP0L register.
- 0= The dot matrix drive function of the LED0 pin is Disabled as a GPIO function;
The pull current drive of the LED0 pin is the default value.
(LEDMODE!=0xAA) Matrix drive mode SEG0 (P04) / software drive P04 pin current drive enable bit;
- 1= The pull current drive of the P04 pin is configured by the LEDSDRP0H register;
- 0= The pull current drive of the P04 pin is the default value.

19.4.14 LED Pin Drive Enable High 8-bit LEDENH

F75FH	Bit7	Bit6	Bit5	Bit4	Bit3	Bit2	Bit1	Bit0
LEDENH	LEDENH7	LEDENH6	LEDENH5	LEDENH4	LEDENH3	LEDENH2	LEDENH1	LEDENH0
R/W	R/W	R/W	R/W	R/W	R/W	R/W	R/W	R/W
Reset value	0	0	0	0	0	0	0	0

- Bit7 LEDENH7:
(LEDMODE==0xAA);
1= Invalid;
0= Invalid.
(LEDMODE!=0xAA) Matrix drive mode SEG15 (P23) / software drive P23 pin current drive enable bit;
1= The pull current drive of the P23 pin is configured by the LEDSDRP2L register;
0= The pull current drive of the P23 pin is the default.
- Bit6 LEDENH6:
(LEDMODE==0xAA);
1= Invalid;
0= Invalid.
(LEDMODE!=0xAA) Matrix drive mode SEG14 (P22) / software drive P22 pin current drive enable bit;
1= The pull current drive of the P22 pin is configured by the LEDSDRP2L register;
0= The pull current drive of the P22 pin is the default.
- Bit5 LEDENH5:
(LEDMODE==0xAA);
1= Invalid;
0= Invalid.
(LEDMODE!=0xAA) Matrix drive mode SEG13 (P21) / software drive P21 pin current drive enable bit;
1= The pull current drive of the P21 pin is configured by the LEDSDRP2L register;
0= The pull current drive of the P21 pin is the default value.
- Bit4 LEDENH4:
(LEDMODE==0xAA);
1= Invalid;
0= Invalid.
(LEDMODE!=0xAA) Matrix drive mode SEG12 (P20) / software drive P20 pin current drive enable bit;
1= The pull current drive of the P20 pin is configured by the LEDSDRP2L register;
0= The pull current drive of the P20 pin is the default.
- Bit3 LEDENH3:
(LEDMODE==0xAA);

		1= Invalid;
		0= Invalid.
		(LEDMODE!=0xAA) Matrix drive mode SEG11 (P17) / software drive P17 pin current drive enable bit;
		1= The pull current drive of the P17 pin is configured by the LEDSDRP1H register;
		0= The pull current drive of the P17 pin is the default value.
Bit2	LEDENH2:	
		(LEDMODE==0xAA);
		1= Invalid;
		0= Invalid.
		(LEDMODE!=0xAA) Matrix drive mode SEG10 (P16) / software drive P16 pin current drive enable bit;
		1= The pull current drive of the P16 pin is configured by the LEDSDRP1H register;
		0= The pull current drive of the P16 pin is the default value.
Bit1	LEDENH1:	
		(LEDMODE==0xAA);
		1= Invalid;
		0= Invalid.
		(LEDMODE!=0xAA) Matrix drive mode SEG9 (P15) / software drive P15 pin current drive enable bit;
		1= The pull current drive of the P15 pins is configured by the LEDSDRP1H register;
		0= The pull current drive of the P15 pin is the default value.
Bit0	LEDENH0:	
		(LEDMODE==0xAA) dot matrix drive mode LED8 (P10) pin function enable bit (pin current drive is the default);
		1= Led8 pins are enabled by dot matrix drive function;
		0= The dot matrix drive function of the LED8 pins is Disabled as a GPIO function.
		(LEDMODE!=0xAA) Matrix drive mode SEG8 (P14) / software drive P14 pin current drive enable bit;
		1= The pull current drive of the P14 pin is configured by the LEDSDRP1H register;
		0= The pull current drive of the P14 pin is the default.

19.5 LED Dot Matrix Drive Interrupt

19.5.1 LED Dot Matrix Drive Status Register LEDSTATUS

F76AH	Bit7	Bit6	Bit5	Bit4	Bit3	Bit2	Bit1	Bit0
LEDSTATUS	--	--	--	--	--	--	LEDIE	LEDIF
R/W	R/W	R/W	R/W	R/W	R/W	R/W	R/W	R/W
Reset value	0	0	0	0	0	0	0	0

- Bit7~Bit2 -- Reserved, must be 0.
- Bit1 LEDIE: LED dot matrix drive mode interrupt enable bit;
 1= LED dot matrix drive mode interrupt enable;
 0= LED dot matrix drive mode interrupt disable.
- Bit0 LEDIF: LED dot matrix drive mode interrupt flag bit
 1= LED dot matrix drive scanning completed;
 0= Software clear 0.

19.5.2 Interrupt Priority Control Register EIP2

0xBA	Bit7	Bit6	Bit5	Bit4	Bit3	Bit2	Bit1	Bit0
EIP2	PSPI	PI2C	PWDT	PADC	PPWM	PLED	PT4	PT3
R/W	R/W	R/W	R/W	R/W	R/W	R/W	R/W	R/W
Reset value	0	0	0	0	0	0	0	0

- Bit7 PSPI: SPI interrupt priority control bit;
 1= Set to High-level Interrupt;
 0= Set to low-level interrupt.
- Bit6 PI2C: I2C interrupt priority control bit;
 1= Set to High-level Interrupt;
 0= Set to low-level interrupt.
- Bit5 PWDT: WDT interrupt priority control bit;
 1= Set to High-level Interrupt;
 0= Set to low-level interrupt.
- Bit4 PADC: ADC interrupt priority control bit;
 1= Set to High-level Interrupt;
 0= Set to low-level interrupt.
- Bit3 PPWM: PWM interrupt priority control bit
 1= Set to High-level Interrupt;
 0= Set to low-level interrupt.
- Bit2 PLED: LED dot matrix scan interrupt priority control bit
 1= Set to High-level Interrupt;
 0= Set to low-level interrupt.
- Bit1 PT4: TIMER4 interrupt priority control bit;
 1= Set to High-level Interrupt;
 0= Set to low-level interrupt.
- Bit0 PT3: TIMER3 interrupt priority control bit;
 1= Set to High-level Interrupt;
 0= Set to low-level interrupt.

20. SPI Module

20.1 Overview

This SPI is a fully configurable SPI master/slave device that allows the user to configure the polarity and phase of the serial clock signal SCLK. The serial clock line (SCLK) is synchronized with the shifting and sampling of information on two independent serial data lines, and the SPI data is sent and received simultaneously. SPI allows the MCU to communicate with serial peripherals, it is also capable of interprocessor-to-processor communication in multi-host systems, and is a technology-independent design that can be implemented in a variety of process technologies.

The SPI system is flexible enough to connect directly with many standard product peripherals from several manufacturers. To accommodate most of the available synchronous serial peripherals, clock control logic allows the selection of clock polarity and phase. The system can be configured as a master device or slave device, and when the SPI is configured as a host device, the software chooses one of eight different bit rates for the serial clock, up to the system clock divided by 4 ($F_{\text{sys}}/4$).

The SPI slave chip selects an addressable SPI slave device to exchange serial data. When the SPI is used as the host device, the SPI auto-drive is selected by the slave selection control register SSCR. The SPI controller includes logical error detection to support interprocessor communication, such as the write conflict detector that indicates when data is written to the serial shift register during transfer.

SPI has the following features:

- ◆ Full-duplex synchronous serial data transfer.
- ◆ Supports master/slave mode.
- ◆ Support for multi-host systems.
- ◆ System error detection.
- ◆ Interrupt generation.
- ◆ Supports speeds up to 1/4 of the system clock ($F_{\text{sys}} \leq 24\text{MHz}$).
- ◆ The bit rate produces 1/4, 1/8, 1/16, 1/32, 1/64, 1/128, 1/256, 1/512 of the system clock.
- ◆ Four transmission formats are supported.
- ◆ The simple interface allows easy connection to the microcontroller.

20.2 SPI Port Configuration

Using the SPI function requires configuring the relevant port as an SPI channel and selecting the corresponding port input through the communication input port registers. For example, configure P00, P01, P02, and P03 as SPI communication ports.

The configuration code is as follows:

```

PS_SCLK = 0x00;   Select P00 as the SCLK channel for the SPI
PS_MOSI = 0x01;  Select P01 for the MOSI channel for the SPI
PS_MISO = 0x02;  Select P02 as the MISO channel for the SPI
PS_NSS = 0x03;   Select P03 as the NSS channel for the SPI
P00CFG = 0x03;   P00 multiplexing for SCLK function
P01CFG = 0x03;   P01 multiplexing for MOSI function
P02CFG = 0x03;   P02 multiplexing for MISO function
P03CFG = 0x03;   P03 multiplexing for NSS function
  
```

Configured as SCLK, MOSI, MISO, and NSS ports, its pull-up resistor and the open-drain output are forced off. The schematic diagram of the multi-slave SPI communication structure is shown in the following figure:

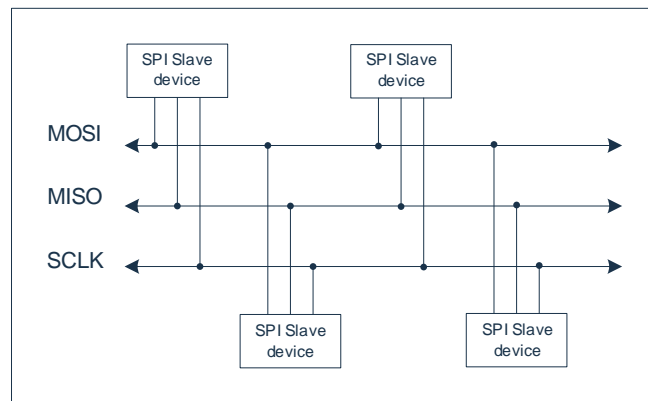

20.3 SPI Hardware Description

When an SPI transfer occurs, when one data pin moves out of one 8-bit character, the other data pin moves in the other 8-bit character. The 8-bit shift register in the master device and another 8-bit shift register in the slave device are connected as a cyclic 16-bit shift register, and when the transfer occurs, the distributed shift register is shifted by 8 bits, thus effectively swapping the characters of the master slave.

The central element in the SPI system is the module containing the shift registers and the buffer for reading data. The system is single buffer in the transmit direction and double buffer in the receive direction. This means that new data cannot be written to the shifter until the previous data transfer is complete; However, the received data is transmitted to a parallel read data buffer, so the shifter is free to receive a second serial character. As long as the first character is read out of the read data buffer before the next serial character is ready for transmission, there is no overwrite. The SPI control block diagram is shown in the following figure:

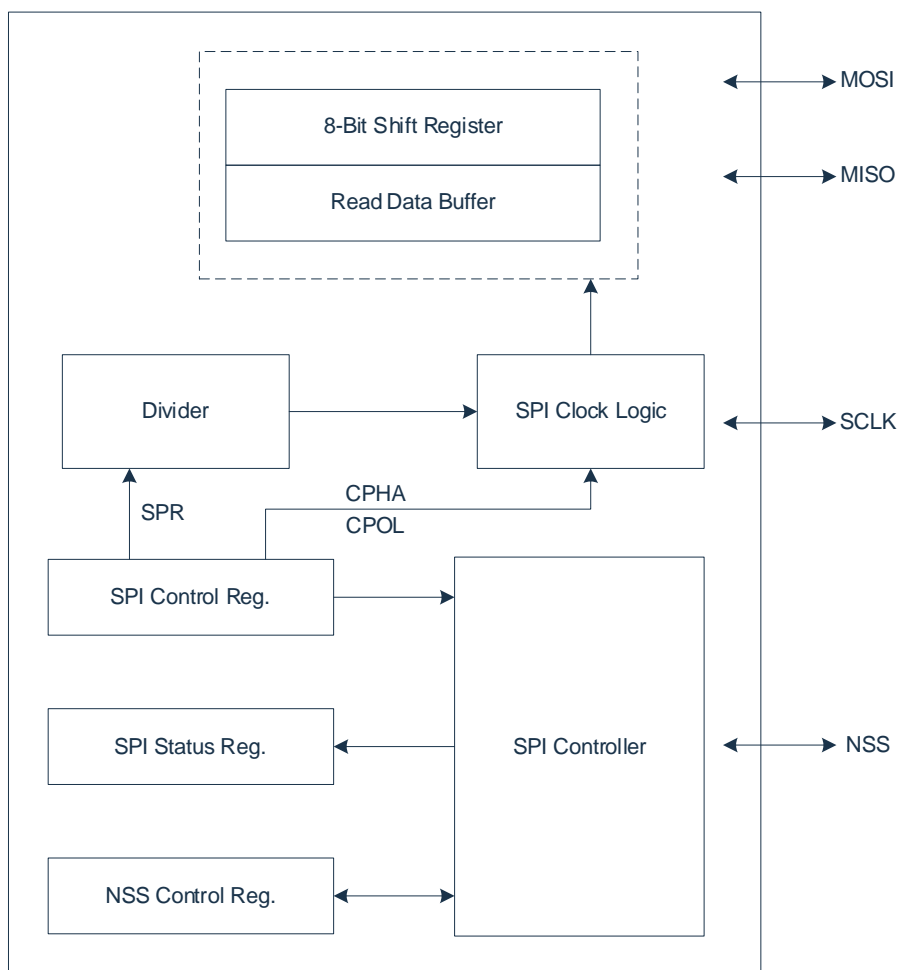

The pins associated with SPI are: NSS, SCLK, MOSI, MISO.

The NSS output pins in master mode are used to select slave devices, and the NSS input pins in slave mode are used to enable transmission.

In host mode, the SCLK pin is used as an SPI clock signal reference. When the host device initiates a transfer, eight clock cycles are automatically generated on the SCLK pins.

When the SPI is configured as a slave device, the SI pin is the slave device input data line and the SO is the slave device output data line.

When the SPI is configured as a host device, the MI pin is the host device input data line and the MO is the host device output data line.

20.4 SPI-related Registers

20.4.1 SPI Control Register SPCR

0xEC	Bit7	Bit6	Bit5	Bit4	Bit3	Bit2	Bit1	Bit0
SPCR	--	SPEN	SPR2	MSTR	CPOL	CPHA	SPR1	SPR0
R/W	R/W	R/W	R/W	R/W	R/W	R/W	R/W	R/W
Reset value	0	0	0	0	0	1	0	0

Bit7	--	Reserved, must be 0.
Bit6	SPEN:	SPI module enable bit; 1= Enable; 0= Disable.
Bit5	SPR2:	The SPI clock frequency selects bit [2].
Bit4	MSTR:	SPI mode select bit; 1= Master mode; 0= Slave mode.
Bit3	CPOL:	SPI clock polarity select bit; 1= SCLK is high when idle; 0= SCLK is low when idle.
Bit2	CPHA:	SPI clock phase select bit.
Bit1~Bit0	SPR<1:0>:	SPI Clock Frequency Select Bit [1:0] (For details of frequency control, see the table below)

The SPR2-SPR0 controls the SPI clock divider

SPR2	SPR1	SPR0	System clock divider
0	0	0	4
0	0	1	8
0	1	0	16
0	1	1	32
1	0	0	64
1	0	1	128
1	1	0	256
1	1	1	512

20.4.2 SPI Data Register SPDR

0xEE	Bit7	Bit6	Bit5	Bit4	Bit3	Bit2	Bit1	Bit0
SPDR	SPIDATA7	SPIDATA6	SPIDATA5	SPIDATA4	SPIDATA3	SPIDATA2	SPIDATA1	SPIDATA0
R/W	R/W	R/W	R/W	R/W	R/W	R/W	R/W	R/W
Reset value	0	0	0	0	0	0	0	0

Bit7~Bit0	SPIDATA<7:0>:	Data sent or received by SPI. Write operation: Write the data that will be sent (the order of sending is from high bit to low bit). Read operation: Data that has been received.
-----------	---------------	--

20.4.3 SPI Device Select Control Register SSCR

The slave device selection control register SSCR can be read or written at any time and is used to configure which slave selection output should be driven when confirming an SPI host transfer. When the SPI host transfer starts, the contents of the SSCR register are automatically assigned to the NSS pin.

0xEF	Bit7	Bit6	Bit5	Bit4	Bit3	Bit2	Bit1	Bit0
SSCR	--	--	--	--	NSSO3	NSSO2	NSSO1	NSSO0
R/W	R/W	R/W	R/W	R/W	R/W	R/W	R/W	R/W
Reset value	1	1	1	1	1	1	1	1

Bit7~Bit4 -- Reserved, must be 1.

Bit3~Bit0 NSSOx: The SPI selects the control bits from the device (the main chip select output NSS is NSSOx, x=0-3).

0= When the SPI host transfer starts, the NSSOx outputs 0.

1= When the SPI host transfer starts, NSSOx outputs 1.

20.4.4 SPI Status Register SPSR

0xED	Bit7	Bit6	Bit5	Bit4	Bit3	Bit2	Bit1	Bit0
SPSR	SPISIF	WCOL	--	--	--	--	--	SSCEN
R/W	R	R	--	R	--	--	R/W	R/W
Reset value	0	0	0	0	0	0	0	0

Bit7 SPISIF: SPI transmission completion interrupt flag bit, read-only;

1= SPI transmission is completed (read SPSR first, then read/write SPDR and then clear zero);

0= The SPI was not transmitted.

Bit6 WCOL: SPI write violation interrupt flag bit, read-only;

1= When the SPI transfer is not completed, a collision of the write SPDR operation occurs (read the SPSR first, then clear the SPDR after reading/writing the SPDR);

0= No write conflicts.

Bit5~Bit1 -- Reserved, must be 0.

Bit0 SSCEN: SPI master mode NSS output control bit.

1= When the SPI is idle, the NSS output is high;

0= NSS output registers the contents of the SSCR.

The SPI Status Register (SPSR) contains flags that indicate that the transfer was complete or that a system error occurred. When the corresponding event occurs and is cleared sequentially by the software, all flags are set automatically. By reading `spsr` and then accessing `spdr`, `SPISIF` and `WCOL` will be automatically cleared.

The `SSCEN` bit is the enable bit of the automatic slave selection output. When `SSCEN` is set to 1, the NSS line outputs the contents of the SSCR register while the transmission is in progress, and the NSS is high when the transmission is idle. When the `SSCEN` bit is cleared, the NSS line always displays the contents of the SSCR registers.

20.5 SPI Master Mode

When SPI is configured for host mode, the transfer is initiated by writing to the SPDR registers. When new bytes are written to the SPDR register, the SPI starts transferring. The serial clock SCLK is generated by the SPI, enabled by the SPI in host mode, and output.

SPI in master mode can select the SPI slave device via the NSS cable. NSS Line - The slave selection output line loads the contents of the SSCR registers. The SSCEN bit of the SPSR register is selected between automatic NSS line control and software control. Place SSCEN in host mode, when SSCEN is set to 1, the NSS line outputs the contents of the SSCR register while the transmission is in progress, and the NSS is high when the transmission is idle. When the SSCEN bit is cleared, the NSS cable is controlled by the software and always displays the contents of the SSCR registers, regardless of whether the transmission is in progress or the SPI is idle.

When SSCEN=1, configure the clock polarity CPOL=0 and the clock phase CPHA=0 for SPI, as shown in the following figure:

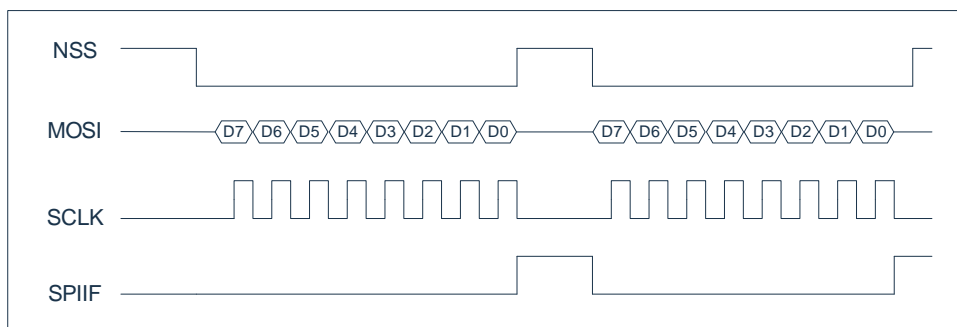

When SSCEN=0, configure the clock polarity CPOL=0 and the clock phase CPHA=0 for SPI, as shown in the following figure:

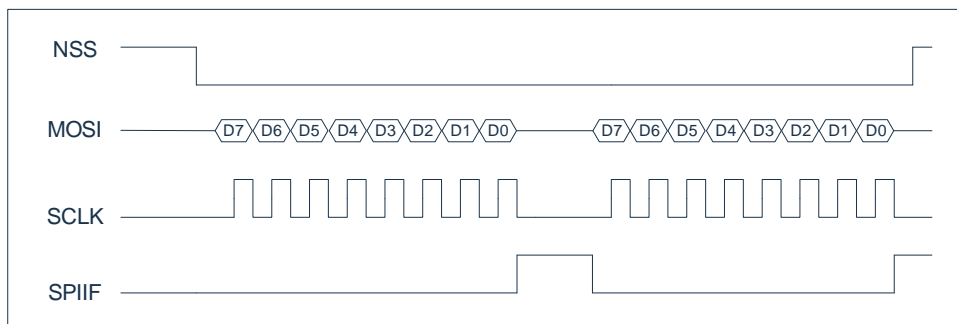

20.5.1 Write Conflict Error

If the SPI data registers are written during the transfer, a write violation occurs. The transfer continues uninterrupted, and the write data that causes the error is not written to the shifter. Write conflicts are indicated by the WCOL flag in the SPSR register.

When a WCOL error occurs, the WCOL flag is automatically set to 1 by the hardware. To clear the WCOL bits, the user should perform the following steps:

- Read the contents of the SPSR register;
- Access the SPDR register (read or write).

In the SPI master mode, the write conflict error when the clock polarity CPOL=0 and the clock phase CPHA=0 of SPI are configured as shown in the following figure:

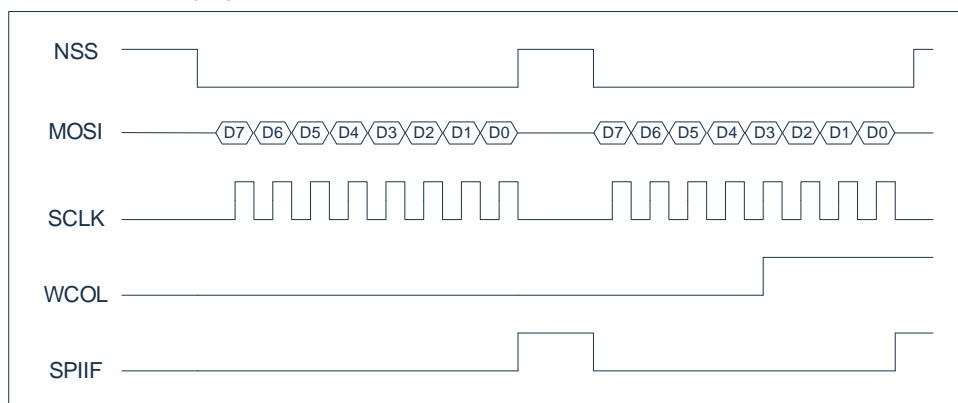

The specific conditions for the occurrence of write conflicts are: during the data transmission process, when the NSS is low, the first data starts to be sent from the moment to the 8th SCLK falling edge, if you write SPDR during this period, a write conflict will occur, and the WCOL will be set to 1.

Note: When you start sending data, after writing spdr, the NSS does not immediately go low, and you need to wait for at most one SPI clock before it starts to be low. After the NSS is low, it is necessary to wait for a system clock to start sending the first data before entering the real data transfer state. Between writing the SPDR to the time it enters the real data transfer state, writing the SPDR again does not create a write conflict. However, the operation updates the data that is ready to be sent. If there are multiple writes to the SPDR, the data sent will be the last value written to the SPDR.

Since SPI has only one transmit buffer, it is recommended to determine whether the last data was sent before writing the SPDR, and then write the SPDR register after the transmission is completed to prevent write conflicts.

20.6 SPI Slave Mode

When configured as an SPI slave device, SPI transmission is initiated by an external SPI host module by using the SPI slave selection input and generates an SCLK serial clock.

Before the transfer begins, it is necessary to determine which SPI slave will be used to exchange data. The NSS is used (clear = 0), and the clock signal connected to the SCLK line will transfer the SPI from the Slave device to the receiving shift register contents of the MOSI line and drive the MISO line with the contents of the transmitter shift registers. When all 8 bits are moved in/out, SPI generates an interrupt request by setting the IRQ output. The contents of the shift register drive the MISO line.

In SPI slave mode, there can only be one transmit error - write conflict error.

20.6.1 Address Error

In slave mode, only write conflict errors can be detected by SPI.

When an SPDR register write operation is performed while an SPI transfer is in progress, a write violation error occurs.

In slave mode, when CPHA is cleared, a write collision error may occur as long as the NSS slave selection line is driven low, even if all bits have been transmitted. This is because the transfer start is not explicitly specified, and the NSS is driven low after a full-byte transfer may indicate the start of the next byte transfer.

20.6.2 Write Conflict Error

If the SPI data register is written during the transfer, a write violation occurs. The transfer continues uninterrupted, and the write data that causes the error is not written to the shifter. Write conflicts are indicated by the WCOL flag in the SPSR register.

When a WCOL error occurs, the WCOL flag is automatically set to 1 by the hardware. To clear the WCOL bits, the user should perform the following sequence:

- Read the contents of the SPSR register;
- Access the SPDR register (read or write).

The following figure shows a write violation error during transfer in SPI slave mode:

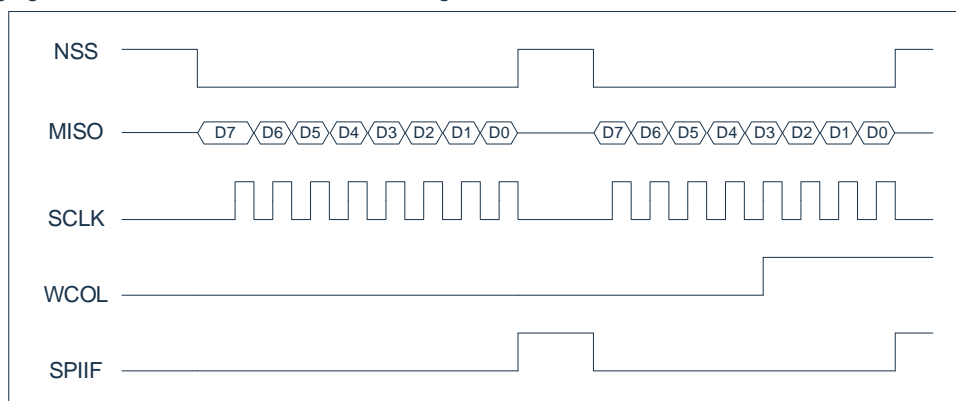

In case the CPHA is cleared, WCOL generation can also be caused by SPDR register writes when either NSS line is cleared, at which point the SPI host can also complete without generating a serial clock SCLK. This is because the transfer start is not explicitly specified, and the NSS is driven low after a full-byte transfer may indicate the start of the next byte transfer. When the NSS transmission line is low and the clock phase CPHA = 0, writing spdr leads to a write collision error as shown in the following figure:

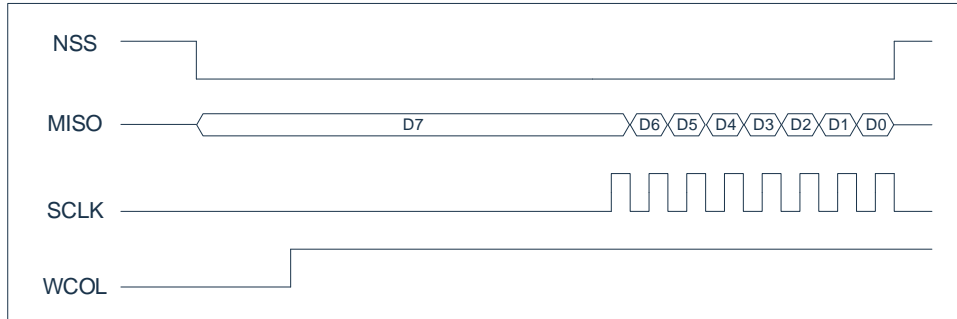

In addition, in slave mode, after writing the SPDR, the host-controlled NSS does not immediately become low. When the NSS is low, you need to wait for the second edge of the SCLK to start before entering the real data transfer state.

Between writing the SPDR and starting to send the first data, writing the SPDR again does not create a write conflict. However, the operation updates the data that is ready to be sent. If there are multiple writes to the SPDR, the data sent will be the last value written to the SPDR.

Writing the SPDR again does not create a write conflict during the start of sending the first data to the second edge of the SCLK, nor does it update the data being sent. That is, the operation of writing the SPDR is ignored.

Since SPI has only one transmit buffer, it is recommended to determine whether the last data was sent before writing the SPDR, and then write the SPDR register after the transmission is completed to prevent write conflicts.

20.7 SPI Clock Control Logic

20.7.1 SPI Clock Phase and Polarity Control

The software can choose to use either of the four combinations of two control bits (phase and polarity of the serial clock SCLK) in the SPI control register (SPCR). Clock polarity is specified by the CPOL control bit, and the CPOL control bit selection high or low level when the transmission is idle has no significant effect on the transmission format. The Clock Phase (CPHA) control bit selects one of two largely different transmission formats. The clock phase and polarity of the master SPI device and the communication slave device should be the same. In some cases, the phase and polarity are changed during transmission to allow the host device to communicate with a peripheral slave with different requirements. The flexibility of the SPI system allows direct connection to almost all existing synchronous serial peripherals.

20.7.2 SPI Transfer Format

During SPI transmission, data is sent simultaneously (serially shift out) and received (serially shift in). The serial clock line is synchronized with the shift and sampling of the two serial data lines. Slave selection line allows the individual selection of slave SPI devices; Slaves that are not selected do not interfere with SPI bus activity. On the SPI host device, the slave selection line may be selectively used to indicate multi-master bus competition.

20.7.3 CPHA=0 Transfer Format

The following figure shows a timing diagram of an SPI transmission with a CPHA of 0. SCLK shows two waveforms: one for CPOL equal to 0 and one for CPOL equal to 1. The figure can be described as a master device or slave device timing diagram through SCLK, where the master in/out (MISO) and master out/out (MOSI) pins are directly connected between the master and slave. The MISO signal is output from the Slave and the MOSI signal is the host output. The slave selection input of the NSS line is slave; The NSS pin of the host is not displayed, but is assumed to be invalid. The NSS pin of the host must be high. This timing diagram functionally describes how the transmission takes place; It should not be used as a substitute for datasheet parameter information.

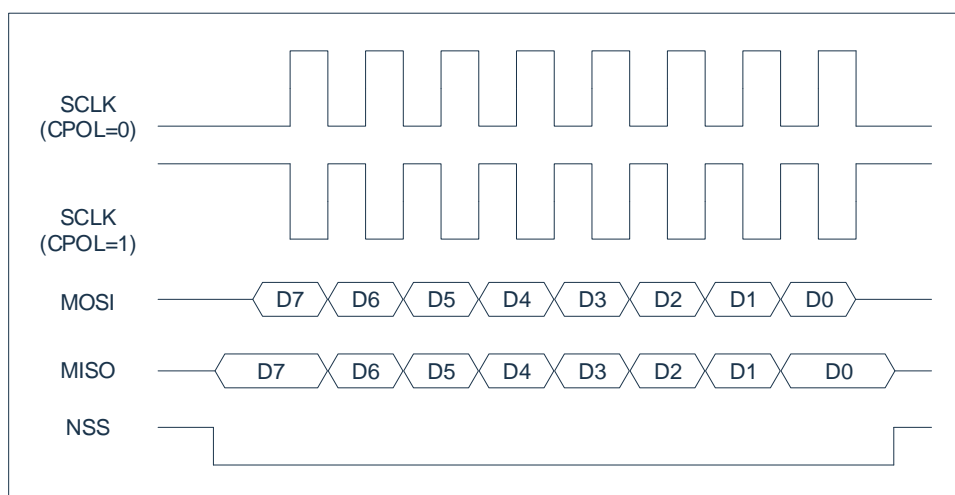

When CPHA=0, the NSS line must unset and Reset between each consecutive serial byte. In addition, if the slave writes data to the SPI Data Register (SPDR) when the NSS is low, a write collision error is generated. When CPHA = 1, the NSS line may remain low between consecutive transmissions (which can always be kept low). In systems with a single fixed master and a single slave driving the MISO data line, this format is sometimes preferred.

20.7.4 CPHA=1 Transfer Format

The following figure is a timing diagram of the SPI transmission with CPHA = 1. SCLK shows two waveforms: one for CPOL=0 and one for CPOL=1. Since the SCLK, MISO, and MOSI pins are directly connected between the master and slave, this diagram can be interpreted as a master or slave timing diagram. The MISO signal is output from the Slave and the MOSI signal is the host output. The slave selection input of the NSS line is slave; The NSS pin of the host is not displayed, but is assumed to be invalid. The NSS pin of the host must be high or must be reconfigured to a general-purpose output that does not affect the SPI.

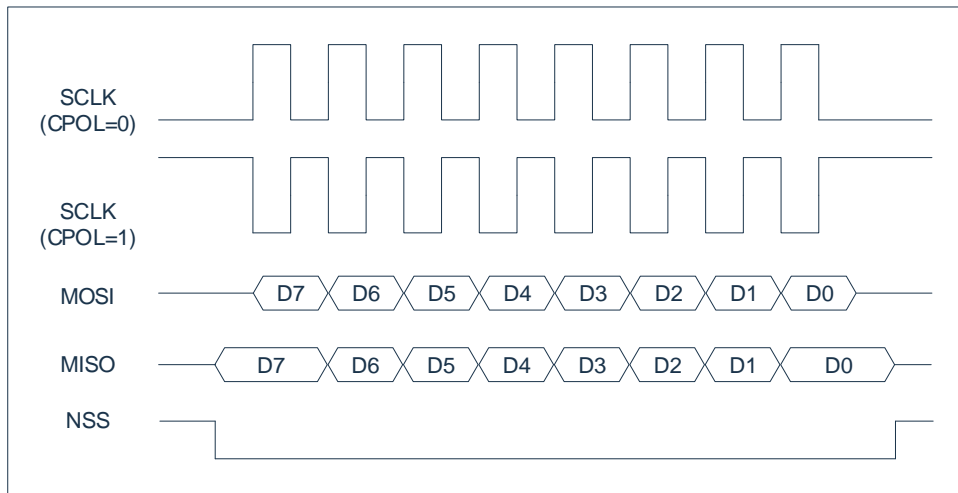

20.8 SPI Data Transfer

20.8.1 SPI Transfer Starts

All SPI transfers are initiated and controlled by the master SPI device. As a slave device, the SPI will consider the transmission starting at the first SCLK edge or the falling edge of the NSS, depending on the CPHA format chosen. When CPHA = 0, the falling edge of the NSS indicates the start of the transmission. When CPHA = 1, the first edge on the SCLK indicates the start of the transfer. Regardless of the CPHA mode, the transmission can be aborted by making the NSS line high, but resetting the SPI slave logic and counter. The SELECTED SCLK rate has no effect on slave operation because the master's clock is controlling the transmission.

When SPI is configured as a host, the transfer is initiated by software that writes to the SPDR.

20.8.2 SPI Transfer Ends

When the SPIF flag is set to 1, the SPI transfer is technically completed, but depending on the configuration of the SPI system, there may be other tasks. Since the SPI bit rate does not affect the timing of the end period, only the fastest rate is considered in the discussion during the end period. When the SPI is configured as a host, the SPIF asserts at the end of the eighth SCLK cycle. When the CPHA is equal to 1, the SCLK is inactive in the last half of the eighth SCLK cycle.

Because the SCLK line can be asynchronous with the slave's MCU clock, and the slave cannot access as much information as the master does to the SCLK cycle, the end cycle is different when the SPI is running as a slave. For example, when CPHA = 1, where the last SCLK edge occurs in the middle of the eighth SCLK cycle, the slave has no way of knowing when the previous SCLK cycle ended. For these reasons, the slave believes that after the last bit of the serial data is sampled, the transmission is complete, which corresponding the middle of the eighth SCLK cycle.

The SPIF flag is set at the end of the transmission, but the NSS line is still low, and the slave does not allow new data to be written to the SPDR.

20.9 SPI Timing Diagram

20.9.1 Master Mode Transmission

When the clock polarity of the SPI is CPOL=0 and the clock phase CPHA=1, the NSS in SPI master mode is the cLK of the system clock after the low level, the MOSI starts to output, and the DATA of the MOSI is output on the rising edge of the SCLK clock. The master mode timing diagram is shown in the following figure:

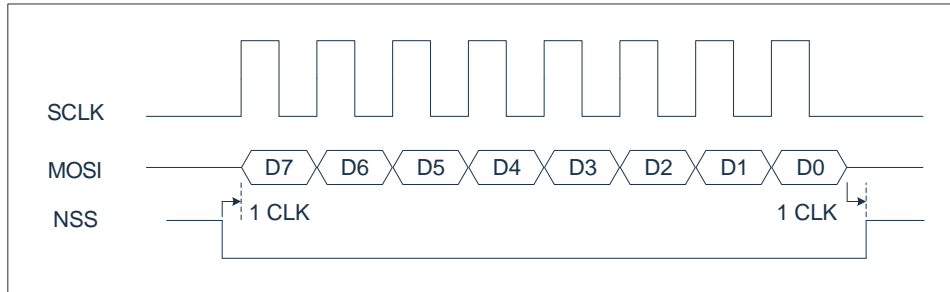

20.9.2 Slave Mode Transmission

When the clock polarity of the SPI is CPOL=0 and the clock phase is CPHA=1, the data on miso starts to output after the falling edge of the NSS line. Miso data output differs from the falling edge of the NSS by a maximum of 1 system clock CLK. The slave mode timing diagram is shown in the following figure:

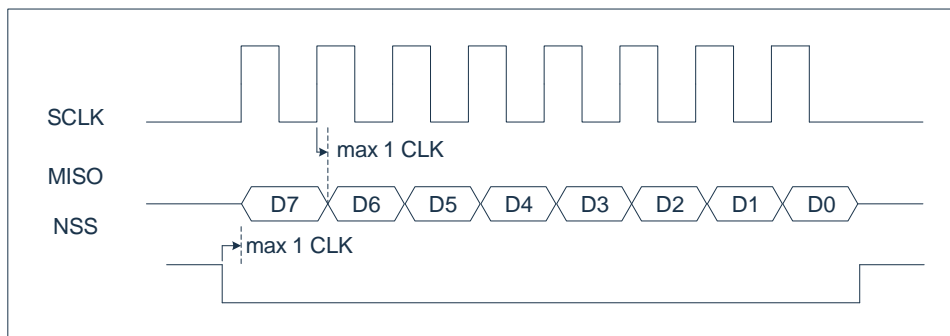

20.10 SPI Interrupt

The interrupt number of the SPI is 22, where the interrupt vector is 0x00B3. To enable an SPI interrupt, it must set its enable bit SPIIE to 1 and the global interrupt enable bit EA to 1.

If the SPI-related interrupt enables are all turned on, the CPU will enter the interrupt service program when the SPI global interrupt indicator bit SPIIF=1. The SPIIF operation properties are read-only and independent of the state of SPIIE.

After the SPI status register SPSR has either of the transmission completion flag SISIF and the write violation WCOL flag 1, the SPI global interrupt indicator bit SPIIF will be set to 1. SPIIF automatically clears 0 only if all three flag bits are 0.

When the clock polarity of the SPI is CPOL=0 and the clock phase is CPHA=1, the SPIIF in the SPI master mode generates cLKs after the rising edge of the eighth SCLK clock in each frame of data, and the timing diagram is shown in the following figure:

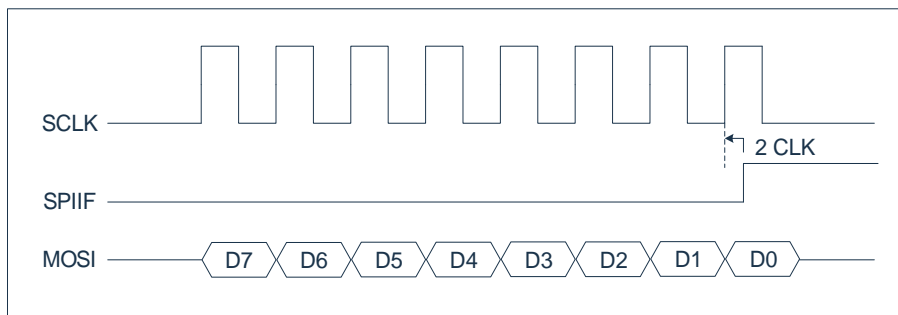

20.10.1 Interrupt Mask Register EIE2

0xAA	Bit7	Bit6	Bit5	Bit4	Bit3	Bit2	Bit1	Bit0
EIE2	SPIIE	I2CIE	WDTIE	ADCIE	PWMIE	--	ET4	ET3
R/W	R/W	R/W	R/W	R/W	R/W	R/W	R/W	R/W
Reset value	0	0	0	0	0	0	0	0

Bit7	SPIIE: SPI interrupt enable bit; 1= Enable SPI interrupts; 0= Disable SPI Interrupt.
Bit6	I2CIE: I2C interrupt enable bit; 1= Enable I2C interrupts; 0= Forbidden I ² C Interrupt.
Bit5	WDTIE: WDT interrupt enable bit; 1= Enable WDT overflow interrupts; 0= Disable WDT overflow interrupts.
Bit4	ADCIE: ADC interrupt enable bit; 1= Enable ADC interrupts; 0= Disable ADC interrupts.
Bit3	PWMIE: PWM global interrupt enable bit; 1= Enable all PWM interrupts; 0= Disable all PWM interrupts.
Bit2	-- Reserved, must be 0.
Bit1	ET4: Timer4 interrupt enable bit; 1= Enable Timer4 interrupts; 0= Forbidden Timer4 Interrupt.
Bit0	ET3: Timer3 interrupt enable bit;

- 1= Enable Timer3 interrupts;
 0= Forbidden Timer3 Interrupt.

20.10.2 Interrupt Priority Control Register EIP2

0xBA	Bit7	Bit6	Bit5	Bit4	Bit3	Bit2	Bit1	Bit0
EIP2	PSPI	PI2C	PWDT	PADC	PPWM	PLED	PT4	PT3
R/W	R/W	R/W	R/W	R/W	R/W	R/W	R/W	R/W
Reset value	0	0	0	0	0	0	0	0

- Bit7 PSPI: SPI interrupt priority control bit;
 1= Set to High-level Interrupt;
 0= Set to low-level interrupt.
- Bit6 PI2C: I2C interrupt priority control bit;
 1= Set to High-level Interrupt;
 0= Set to low-level interrupt.
- Bit5 PWDT: WDT interrupt priority control bit;
 1= Set to High-level Interrupt;
 0= Set to low-level interrupt.
- Bit4 PADC: ADC interrupt priority control bit;
 1= Set to High-level Interrupt;
 0= Set to low-level interrupt.
- Bit3 PPWM: PWM interrupt priority control bit
 1= Set to High-level Interrupt;
 0= Set to low-level interrupt.
- Bit2 PLED: LED dot matrix scan interrupt priority control bit
 1= Set to High-level Interrupt;
 0= Set to low-level interrupt.
- Bit1 PT4: TIMER4 interrupt priority control bit;
 1= Set to High-level Interrupt;
 0= Set to low-level interrupt.
- Bit0 PT3: TIMER3 interrupt priority control bit;
 1= Set to High-level Interrupt;
 0= Set to low-level interrupt.

20.10.3 Peripheral Interrupt Flag Bit Register EIF2

0xB2	Bit7	Bit6	Bit5	Bit4	Bit3	Bit2	Bit1	Bit0
EIF2	SPIIF	I2CIF	--	ADCIF	PWMIF	--	TF4	TF3
R/W	R	R	--	R/W	R	--	R/W	R/W
Reset value	0	0	0	0	0	0	0	0

- Bit7 SPIIF: SPI global interrupt indicator bit, read-only;
 1= SPI generates an interrupt, (this bit is automatically cleared after the specific interrupt flag is cleared);
 0= The SPI did not produce an interrupt.
- Bit6 I2CIF: I2C global interrupt indicator bit, read-only;
 1= I2C produces an interrupt, (after clearing the specific interrupt flag, this bit is automatically cleared);
 0= I2C did not produce an interrupt.
- Bit5 -- Reserved, must be 0.
- Bit4 ADCIF: ADC interrupt flag bit;
 1= ADC conversion is completed, and software zeroing is required;
 0= The ADC conversion was not completed.
- Bit3 PWMIF: PWM global interrupt indicator bit, read-only;
 1= PWM generates an interrupt, (after the specific interrupt flag is cleared, this bit is automatically cleared);
 0= The PWM did not produce an interrupt.
- Bit2 -- Reserved, must be 0.
- Bit1 TF4: Timer4 timer overflow interrupt flag bit;
 1= Timer4 timer overflow, the hardware is automatically cleared when entering the interrupt service program, and the software can also be cleared;
 0= The Timer4 timer has no overflow.
- Bit0 TF3: Timer3 timer overflow interrupt flag bit;
 1= Timer3 timer overflow, when entering the interrupt service program, the hardware is automatically cleared, and the software can also be cleared;
 0= The Timer3 timer has no overflow.

21. I2C Module

21.1 Overview

The module provides an interface between the microcontroller and the I2C bus, as shown in the connection diagram below, and supports arbitration and clock synchronization to allow operation in multi-master systems. I2C supports normal, fast mode.

The I2C module has the following characteristics:

- ◆ Support 4 working modes: master transmission, master reception, slave transmission, slave reception.
- ◆ Supports 2 transfer speed modes:
 - Standard (up to 100Kb/s);
 - Fast (up to 400Kb/s);
- ◆ Perform arbitration and clock synchronization.
- ◆ Support for multi-master systems.
- ◆ The master mode supports 7-bit addressing mode and 10-bit addressing mode on the I2C-bus (software supported).
- ◆ Slave mode supports 7-bit addressing mode on the I2C-bus.
- ◆ Interrupt generation.
- ◆ Allows operation over a wide clock frequency range (built-in 8-bit timer).

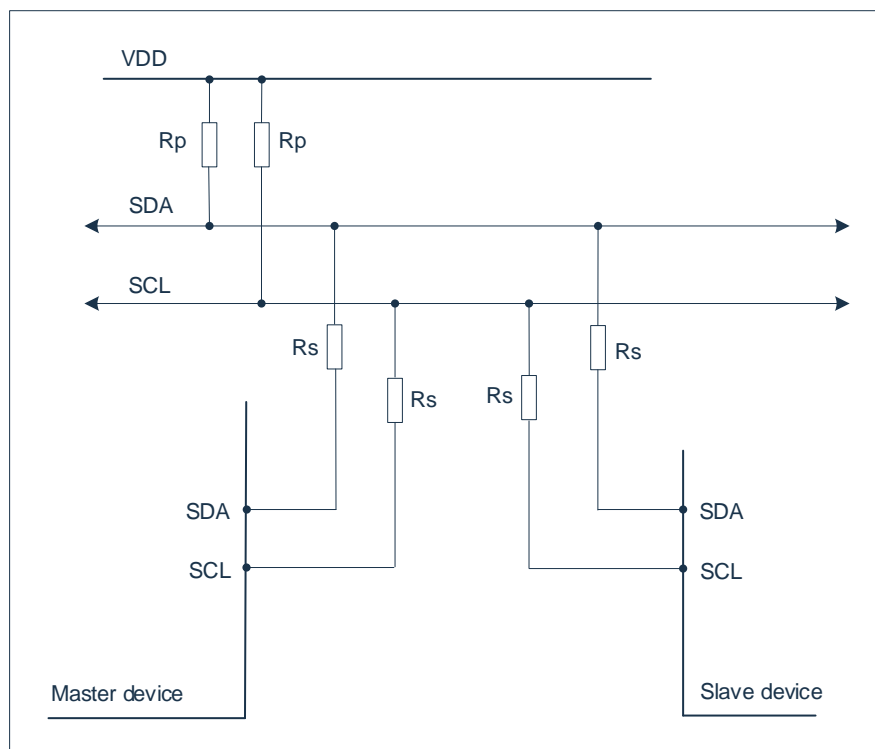

21.2 I2C Port Configuration

If you use the I2C function, you should first configure the corresponding port as an SCL, SDA channel. For example, configure P00, P01 port as I2C function:

```
PS_SCL = 0x00;   Select the P00 port as the SCL pin
PS_SDA = 0x01;   /Select the P01 port as the SDA pin
P00CFG = 0x02;   P00 multiplexes the SCL function
P01CFG = 0x02;   P01 multiplexed SDA function
```

After configuring the I2Cchannel, this group of ports defaults to the open-drain state, that is, the open-drain output when outputting data 1. PxUP can be configured to enable SCL, the internal pull-up resistor of the SDA port, or to add a pull-up resistor outside the chip.

In the master control mode, IIC outputs SCL to the slave. After sending the address or data, the slave needs to lower the SCL and send back the corresponding response signal to the master. The host needs to read back the SCL port line status to detect whether the slave releases the SCL to determine whether the next frame of data transmission is required. The larger the pull-up resistance or board level parasitic capacitance of the SCL, the longer the read back time will be, which will affect the communication speed of the IIC. For details, refer to the IIC Application Manual.

21.3 I2C Master Mode

There are six registers for connecting to the master: control, status, slave address, transmit data, receive data, and timer cycle registers.

register		address
write	Read	
Slave address register I2CMSA	Slave address register I2CMSA	0xF4
Master mode control register I2CMCR	Master mode status register I2CMSR	0xF5
The master transmits the data register I2CMBUF	The master receives data register I2CMBUF	0xF6
Timing cycle register I2CMTP	Timing cycle register I2CMTP	0xF7

The master mode control register I2CMCR shares a register address with the master mode status register I2CMSR, but is physically two different registers.

The master transmit data register shares a register address with the master receive data register, and the write operation accesses the transmit register I2CMBUF and the read operation accesses the receiving register I2CMBUF.

Write operations are written as control registers, and read operations are read as status registers.

21.3.1 I2C Master Mode Timing Cycle Register

To generate a wide range of SCL frequencies, the module has a built-in 8-bit timer. For standard and fast transfers.

TIMER_PRD \neq 0, the clock period of the SCL: $2 * (1 + \text{TIMER_PRD}) * 10 * T_{\text{sys}}$

TIMER_PRD = 0, the clock period of the SCL: $3 * 10 * T_{\text{sys}}$

Refer to IIC Application Manual for specific calculation formula of SCL.

0xF7	Bit7	Bit6	Bit5	Bit4	Bit3	Bit2	Bit1	Bit0
I2CMTP	--	MTP6	MTP5	MTP4	MTP3	MTP2	MTP1	MTP0
R/W	R/W	R/W	R/W	R/W	R/W	R/W	R/W	R/W
Reset value	0	0	0	0	0	0	0	1

Bit7 -- Reserved, must be 0.

Bit6~Bit0 MTP<6:0>: Period timing registers in standard and fast modes, bits 6-0: TIMER_PRD [6:0].

21.3.2 I2C Master Mode Control and Status Registers

The control registers include 4 bits: RUN, START, STOP, ACK bits. The START bit will produce the START or RESTART START condition. The STOP bit determines whether the data transfer stops at the end of the cycle, or continues. To generate a single transmission cycle, the slave address register writes to the desired address, the R/S bit is set to 0, and the control register writes to ACK=x, STOP=1, START=1, RUN=1 (I2CMCR=xxx0_x111x) to perform the operation and stop. An interrupt occurs when the operation completes (or an error occurs). Data can be read from the receiving data register.

When I2C is operating in master mode, the ACK bit must be set to 1. This will cause the I2C-Bus controller to automatically send a reply after each byte. When the I2C-bus controller no longer needs to send data from the slave, the bit must clear 0.

Master mode control registers

0xF5	Bit7	Bit6	Bit5	Bit4	Bit3	Bit2	Bit1	Bit0
I2CMCR	RSTS	--	--	--	ACK	STOP	START	RUN
R/W	In	R	R	In	In	In	In	In
Reset value	0	0	1	0	0	0	0	0

Bit7	RSTS: I2C active module reset control position; 1= Reset the master module (I2C registers for the entire master module, including I2CMSR); 0= The interrupt flag bit in I2C master mode is clear to 0.
Bit6~Bit5	-- Retain.
Bit4	-- Reserved, must be 0.
Bit3	ACK: Answer enable bit; 1= Enable; 0= Disable.
Bit2	STOP: Stop enable bit; 1= Enable; 0= Disable.
Bit1	START: Start the enable bit; 1= Enable; 0= Disable.
Bit0	RUN: Run the enable bit; 1= Enable; 0= Disable.

Various operations in master mode can be implemented through the following list of control bit combinations:

START: Sends a start signal.

SEND: Send data or address.

RECEIVE: Receives data.

STOP: Send an end signal.

Combination of control bits (IDLE state)

R/S	ACK	STOP	START	RUN	OPERATION
0	-	0	1	1	START followed by SEND (master remains in send mode)
0	-	1	1	1	START is followed by SEND and STOP
1	0	0	1	1	Non response is adopted for receiving after START (master remains in receiver mode)
1	0	1	1	1	START is followed by REVIVE and STOP
1	1	0	1	1	START followed by RECOVER (master remains in receiver mode)
1	1	1	1	1	Combinations are prohibited
0	0	0	0	1	Combinations are prohibited

Combination of control bits (master send status)

R/S	ACK	STOP	START	RUN	OPERATION
-	-	0	0	1	Send operation
-	-	1	0	0	Stop it
-	-	1	0	1	SEND is followed by STOP
0	-	0	1	1	Repeat START followed by SEND
0	-	1	1	1	Repeat START, followed by SEND and STOP
1	0	0	1	1	Repeat the START condition followed by the response TOCAIVE operation (Master remains in receiver mode)
1	0	1	1	1	Repeat THEART, followed by the SEND and STOP conditions
1	1	0	1	1	Repeat the START condition followed by RECEIVE (Master remains in receiver mode)
1	1	1	1	1	Combinations are prohibited

Combination of control bits (master receive state)

R/S	ACK	STOP	START	RUN	OPERATION
-	0	0	0	1	Respond operation with answers (Master remains in receiver mode)
-	-	1	0	0	STOP
-	0	1	0	1	RECEIVE is followed by STOP
-	1	0	0	1	RECEIVE operation (master remains in receiver mode)
-	1	1	0	1	Combinations are prohibited
1	0	0	1	1	The START is repeated, followed by a response TOCEIVE operation (Master remains in receiver mode)
1	0	1	1	1	Repeat START, followed by RECOVER and STOP
1	1	0	1	1	Repeat START followed by RECONSIDERATION (Master remains in receiver mode)
0	-	0	1	1	Repeat START followed by SEND (Master remains in transmitter mode)
0	-	1	1	1	Repeat START, followed by SEND and STOP

Master mode status register I2CMSR

0xF5	Bit7	Bit6	Bit5	Bit4	Bit3	Bit2	Bit1	Bit0
I2CMSR	I2CMIF	BUS_BUSY	IDLE	ARB_LOST	DATA_ACK	ADD_ACK	ERROR	BUSY
R/W	R	R	R	R	R	R	R	R
Reset value	0	0	1	0	0	0	0	0

- Bit7 I2CMIF: I2C Master mode interrupt flag bit;
 1= In master mode, send/receive completes, or a transmission error occurs. (Software zero, write 0 to clear);
 0= No interrupt was generated.
- Bit6 BUS_BUSY: I2C-bus busy flag bit in master mode/slave mode;
 1= The I2C-bus is busy and cannot be transmitted (cleared by the start bit set to 1 on the bus, stop condition).
 0= --
- Bit5 IDLE: I2C Master mode idle flag bit;
 1= is idle;
 0= is the working status.
- Bit4 ARB_LOST: I2C Master Mode Arbitration Flag Bit;
 1= Bus control is lost.
 0= --
- Bit3 DATA_ACK: I2C master mode transmits data response flag bits;
 1= The last time the data was sent was not answered.
 0= --
- Bit2 ADD_ACK: I2C Master Mode Addressing Answer Flag Bit;
 1= The last addressing did not answer.
 0= --
- Bit1 ERROR: I2C Master mode error flag bit;
 1= Addressing slaves does not answer/send data without answer/I2C-bus arbitration conflicts.
 0= --
- Bit0 BUSY: I2C Master module busy flag bit;
 1= The I2C Module is transferring data.
 0= --

21.3.3 I2C Slave Address Register

The slave address register consists of 8 bits: 7 bits of address (A6-A0) and receive/transmit bits R/S. The R/S bit determines whether the next operation is to receive (1) or send (0).

Master mode slave address register I2CMSA

0xF4	Bit7	Bit6	Bit5	Bit4	Bit3	Bit2	Bit1	Bit0
I2CMSA	SA6	SA5	SA4	SA3	SA2	SA1	SA0	R/S
R/W	R/W	R/W	R/W	R/W	R/W	R/W	R/W	R/W
Reset value	0	0	0	0	0	0	0	0

Bit7~Bit1 AT<6:0>: I2C Master mode slave address.
 Bit0 R/S: I2C Master mode after sending slave address after receiving/sending status selection bits;
 1= Receive data after correct addressing;
 0= The data is sent after correct addressing.

21.3.4 I2C Master Mode Transmit and Receive Data Registers

The transmit data register consists of eight data bits that will be sent on the bus on the next send or burst send operation, the first of which is MD7 (MSB).

Master mode data cache register I2CMBUF

0xF6	Bit7	Bit6	Bit5	Bit4	Bit3	Bit2	Bit1	Bit0
I2CMBUF	MD7	MD6	MD5	MD4	MD3	MD2	MD1	MD0
R/W	R/W	R/W	R/W	R/W	R/W	R/W	R/W	R/W
Reset value	0	0	0	0	0	0	0	0

Bit7~Bit0 MD<7:0>: Send/receive data in I2C master mode.

21.4 I2C Slave Mode

There are five registers for connecting to the target device: self address, control, status, send data, and receive data registers.

register		address
write	Read	
Self address register I2CSADR	Self address register I2CSADR	0xF1
Control register I2CSCR	Status register I2CSSR	0xF2
Send data I2CSBUF	Receive data I2CSBUF	0xF3

21.4.1 I2C Own Address Register I2CSADR

The own address register consists of seven address bits that identify the I2C core on the I2C bus. This register can R/W addresses.

Own address register I2CSADR

0xF1	Bit7	Bit6	Bit5	Bit4	Bit3	Bit2	Bit1	Bit0
I2CSADR	--	SA6	SA5	SA4	SA3	SA2	SA1	SA0
R/W	R	R/W	R/W	R/W	R/W	R/W	R/W	R/W
Reset value	0	0	0	0	0	0	0	0

Bit7 -- Reserved, must be 0.
 Bit6~Bit0 AT<6:0>: The own address of the I2C slave mode.

21.4.2 I2C Slave Mode Control and Status Registers I2CSCR/I2CSSR

Slave mode control registers and slave mode status registers occupy a register address, using different operations to access the two registers separately:

Write operation: Write to I2CSCR (write only)

Read operation: Read I2CSSR (read-only)

The control register consists of two bits: RSTS and DA bits. The RSTS bit controls the reset of the entire I2C Slave module, and when the I2C bus encounters some problem, the software enables the bit to reinitialize the I2CS. The DA bit enables and disables I2CS device operation. Reading this address places the status register on the data bus.

Slave mode control register I2CSCR

0xF2	Bit7	Bit6	Bit5	Bit4	Bit3	Bit2	Bit1	Bit0
I2CSCR	RSTS	--	--	--	--	--	--	OF
R/W	In	R	R	R	R	R	R	In
Reset value	0	0	0	0	0	0	0	0

Bit7 RSTS: I2Cslave module reset control bit;
 1= Reset slave module;
 0= No impact.
 Bit6~Bit1 -- Reserved, must be 0.
 Bit0 OF: I2C Slave mode enable bit;
 1= Enable;
 0= Disable.

The status register consists of three bits: sendfin bit, RREQ bit, TREQ bit. The SENDFIN bit of Send Complete indicates that the Master I2C controller has completed the receipt of data during a single or continuous I2CS transmit operation. The Receive Request RREQ bit indicates that the I2CS device has received a data byte from the I2C master, and the I2CS device should read a data byte from the receiving data register I2CSBUF. The Send Request TREQ bit indicates that the I2CS device is addressed as a slave transmitter, and the I2CS device should write a byte of data to the transmit data register I2CSBUF. If the I2C interrupt enable is on, any of the 3 flags at 1 will produce an interrupt.

The bus busy flag in the slave mode is judged by bit6 (BUS_BUSY) of the master mode status register I2CMSR, which is 0x20 when the bus is idle, the I2CMSR register is 0x60 when the start condition is generated and the stop condition is generated, and the I2CMSR is 0x20 when the stop condition is generated.

Slave mode status register I2CSSR

0xF2	Bit7	Bit6	Bit5	Bit4	Bit3	Bit2	Bit1	Bit0
I2CSSR	--	--	--	--	--	SENDFIN	TREQ	RREQ
R/W	--	--	--	--	--	R	R	R
Reset value	0	0	0	0	0	0	0	0

Bit7~Bit3 -- Reserved, must be 0.

Bit2 SENDFIN: I2C Slave mode sends the operation completion flag bit, read-only.

1= The data is no longer required by the master device, the TREQ is no longer set to 1, and the data transfer has been completed. (Automatic zeroing after reading I2CSCR).

0= --

Bit1 TREQ: I2C Slave mode prepares to send flag bits, read-only.

1= As the transmitting device has been addressed or the master device is ready to receive data. (Auto zero after writing I2CSBUF).

0= --

Bit0 RREQ: I2C slave mode receives completion flag bits, read-only.

1= Received. (Automatic zeroing after reading I2CSBUF).

0= Not received.

21.4.3 I2C Slave Mode Transmit and Receive Buffer Registers I2CSBUF

0xF3	Bit7	Bit6	Bit5	Bit4	Bit3	Bit2	Bit1	Bit0
I2CSBUF	I2CSBUF7	I2CSBUF6	I2CSBUF5	I2CSBUF4	I2CSBUF3	I2CSBUF2	I2CSBUF1	I2CSBUF0
R/W	R/W	R/W	R/W	R/W	R/W	R/W	R/W	R/W
Reset value	0	0	0	0	0	0	0	0

Bit7~Bit0 I2CSBUF<7:0>: data sent or received by I2C;

Write operation: Write the data that will be sent (the order of sending is from the high bit to the low bit);

Read operation: Data that has been received.

21.5 I2C Interrupt

The interrupt number for I2C is 21, where the interrupt vector is 0x00AB. The Enable I2C interrupt must set its enable bit I2CIE to 1 and the global interrupt enable bit EA to 1.

If the I2C-related interrupt enables are turned on, the CPU will enter the interrupt service program when the I2C global interrupt indicator bit I2CIF=1 is turned on. The I2CIF operation properties are read-only and independent of the state of the I2CIE.

I2C Master Mode Interrupt Flag Bit I2CMIF, Slave mode Transmit Operation Completion Flag Bit SENDFIN, Slave mode Ready to Send Flag Bit TREQ, Slave mode Receive Completion Flag Bit RREQ Any one is 1, I2C Global interrupt Indicator Bit I2CIF will be set to 1. I2CIF automatically clears 0 only if all four flag bits are 0.

21.5.1 Interrupt Mask Register EIE2

0xAA	Bit7	Bit6	Bit5	Bit4	Bit3	Bit2	Bit1	Bit0
EIE2	SPIIE	I2CIE	WDTIE	ADCIE	PWMIE	--	ET4	ET3
R/W	R/W	R/W	R/W	R/W	R/W	R/W	R/W	R/W
Reset value	0	0	0	0	0	0	0	0

Bit7	SPIIE: SPI interrupt enable bit; 1= Enable SPI interrupts; 0= Disable SPI Interrupt.
Bit6	I2CIE: I2C interrupt enable bit; 1= Enable I2C interrupts; 0= Forbidden I2C Interrupt.
Bit5	WDTIE: WDT interrupt enable bit; 1= Enable WDT overflow interrupts; 0= Disable WDT overflow interrupts.
Bit4	ADCIE: ADC interrupt enable bit; 1= Enable ADC interrupts; 0= Disable ADC interrupts.
Bit3	PWMIE: PWM global interrupt enable bit; 1= Enable all PWM interrupts; 0= Disable all PWM interrupts.
Bit2	-- Reserved, must be 0.
Bit1	ET4: Timer4 interrupt enable bit; 1= Enable Timer4 interrupts; 0= Forbidden Timer4 Interrupt.
Bit0	ET3: Timer3 interrupt enable bit; 1= Enable Timer3 interrupts; 0= Forbidden Timer3 Interrupt.

21.5.2 Interrupt Priority Control Register EIP2

0xBA	Bit7	Bit6	Bit5	Bit4	Bit3	Bit2	Bit1	Bit0
EIP2	PSPI	PI2C	PWDT	PADC	PPWM	PLED	PT4	PT3
R/W	R/W	R/W	R/W	R/W	R/W	R/W	R/W	R/W
Reset value	0	0	0	0	0	0	0	0

- Bit7 PSPI: SPI interrupt priority control bit;
 1= Set to High-level Interrupt;
 0= Set to low-level interrupt.
- Bit6 PI2C: I2C interrupt priority control bit;
 1= Set to High-level Interrupt;
 0= Set to low-level interrupt.
- Bit5 PWDT: WDT interrupt priority control bit;
 1= Set to High-level Interrupt;
 0= Set to low-level interrupt.
- Bit4 PADC: ADC interrupt priority control bit;
 1= Set to High-level Interrupt;
 0= Set to low-level interrupt.
- Bit3 PPWM: PWM interrupt priority control bit
 1= Set to High-level Interrupt;
 0= Set to low-level interrupt.
- Bit2 PLED: LED dot matrix scan interrupt priority control bit
 1= Set to High-level Interrupt;
 0= Set to low-level interrupt.
- Bit1 PT4: TIMER4 interrupt priority control bit;
 1= Set to High-level Interrupt;
 0= Set to low-level interrupt.
- Bit0 PT3: TIMER3 interrupt priority control bit;
 1= Set to High-level Interrupt;
 0= Set to low-level interrupt.

21.5.3 Peripheral Interrupt Flag Bit Register EIF2

0xB2	Bit7	Bit6	Bit5	Bit4	Bit3	Bit2	Bit1	Bit0
EIF2	SPIIF	I2CIF	--	ADCIF	PWMIF	--	TF4	TF3
R/W	R	R	--	R/W	R	--	R/W	R/W
Reset value	0	0	0	0	0	0	0	0

- Bit7 SPIIF: SPI global interrupt indicator bit, read-only;
 1= SPI generates an interrupt, (this bit is automatically cleared after the specific interrupt flag is cleared);
 0= The SPI did not produce an interrupt.
- Bit6 I2CIF: I2C global interrupt indicator bit, read-only;
 1= I2C produces an interrupt, (after clearing the specific interrupt flag, this bit is automatically cleared);
 0= I2C did not produce an interrupt.
- Bit5 -- Reserved, must be 0.
- Bit4 ADCIF: ADC interrupt flag bit;
 1= ADC conversion is completed, and software zeroing is required;
 0= The ADC conversion was not completed.
- Bit3 PWMIF: PWM global interrupt indicator bit, read-only;
 1= PWM generates an interrupt, (after the specific interrupt flag is cleared, this bit is automatically cleared);
 0= The PWM did not produce an interrupt.
- Bit2 -- Reserved, must be 0.
- Bit1 TF4: Timer4 timer overflow interrupt flag bit;
 1= Timer4 timer overflow, the hardware is automatically cleared when entering the interrupt service program, and the software can also be cleared;
 0= The Timer4 timer has no overflow.
- Bit0 TF3: Timer3 timer overflow interrupt flag bit;
 1= Timer3 timer overflow, when entering the interrupt service program, the hardware is automatically cleared, and the software can also be cleared;
 0= The Timer3 timer has no overflow.

21.6 I2C Slave Mode Transmission Mode

All rendered waveforms in this section default I2C to have their own address 0x39 ("00111001").

21.6.1 Single Receive

The following figure shows the sequence of signals received by I2C during a single data session. Single receive sequence:

- Starting conditions;
- The I2C is addressed by the I2C master as the receiver;
- The address is confirmed by I2C;
- Data received by I2C;
- Data confirmed by I2C;
- Stop condition.

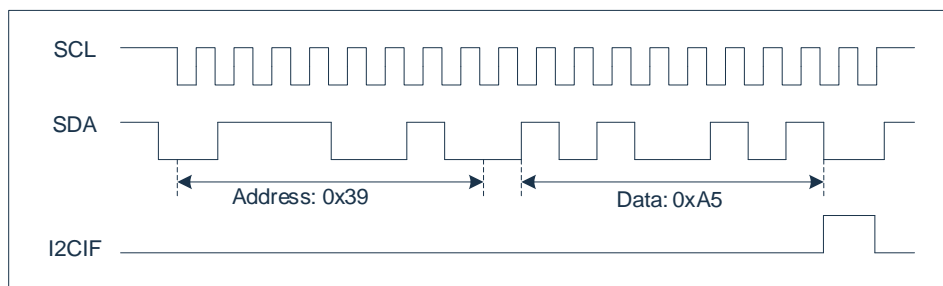

21.6.2 Single Send

The following figure shows the sequence of signals sent by I2C during a single data session. Single send sequence:

- Starting conditions;
- I2C is addressed by the I2C master as a transmitter;
- The address is confirmed by I2C;
- Data is transmitted by I2C;
- Data is not confirmed by the I2C master;
- Stop condition.

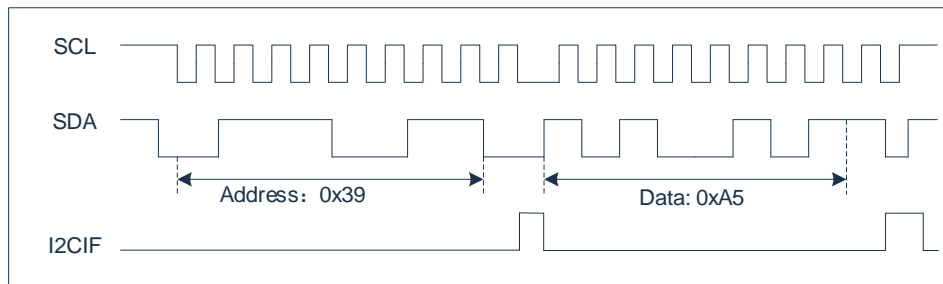

21.6.3 Continuous Reception

The following figure shows the sequence of signals received by I2C during continuous data reception. Continuous receive sequence:

- Start conditions.
- I2C is addressed by the I2C master as a receiver.
- The address is confirmed by I2C.
- 1) Data is received by I2C.
- 2) The data is confirmed by I2C.
- Stop condition.

Sequences 1) and 2) repeat until the stop condition occurs.

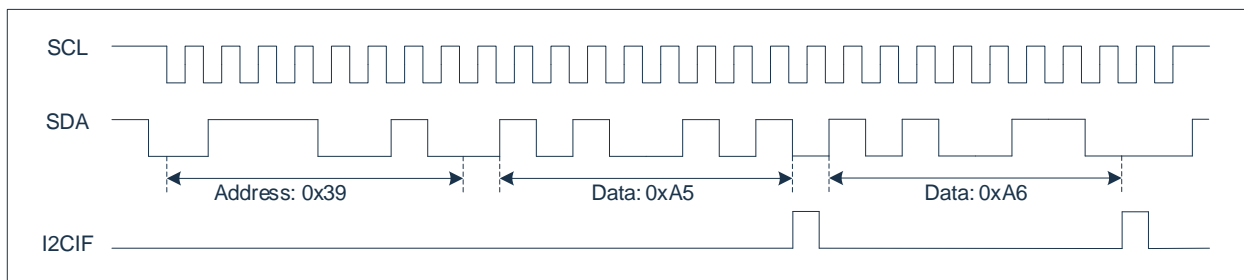

21.6.4 Continuous Sending

The following figure shows the sequence of signals sent by I2C during continuous data transmission. Consecutive send sequences:

- Send conditions.
- I2C is addressed by the I2C master as a transmitter.
- The address is confirmed by I2C.
- 1) The data is sent by I2C.
- 2) Data I2C master acknowledges data.
- 3) The last data is not confirmed by the I2C master.
- Stop condition.

Repeat sequences 1) and 2) until the last data sent is not confirmed by the I2C master 3).

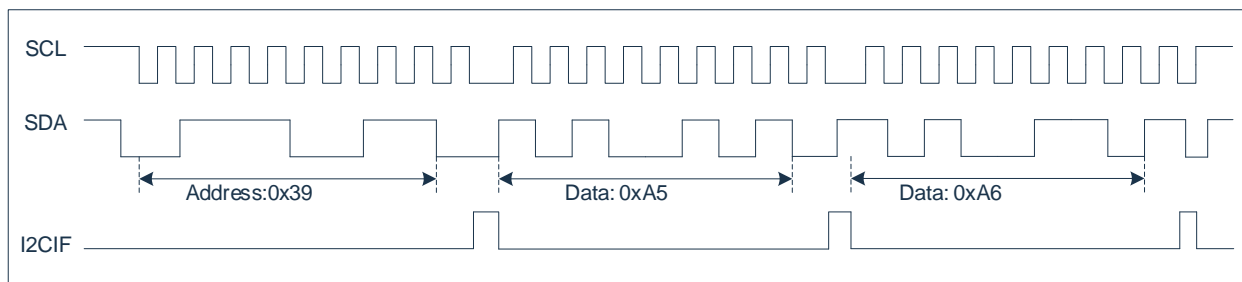

22. UARTn Module

22.1 Overview

The Universal Synchronous Asynchronous Transceiver (UART0/UART1) provides a flexible way to exchange full-duplex data with external devices.

UARTn has two physically separate receive and transmit buffers, SBUF_n, which distinguish between operations on a receive buffer or a transmit buffer by reading and writing instructions to SBUF_n. When writing SBUF_n, data is loaded into the send buffer; When reading SBUF_n, the contents of the receive buffer are read.

UARTn has four modes of operation: one synchronous mode and three asynchronous modes. Modes 2 and 3 have a multi-machine communication function that is enabled by placing SM_n2 bit set to 1 in the SCONN register. The master processor first sends the address byte that identifies the target slave. Address bytes are different from data bytes in that bit 9 in the address byte is 1 and data bytes are 0. At SM_n2=1, the slave is not interrupted by bytes of data. The address byte will interrupt all slaves. The addressed slave will clear its SM_n2 bits and prepare to receive incoming bytes of data. The unaddressed slave sets smn2 to 1 and ignores the incoming data.

22.2 UARTn Port Configuration

Before using the UARTn module, you need to configure the corresponding port as the TXD_n and RXD_n channels of UARTn. For example, the port configuration of UART0 is as follows:

```
PS_RXD0 = 0x05; Select P05 as the RXD0 pin
P05CFG = 0x02; P05 multiplexing for RXD0 function
P04CFG = 0x02; P04 multiplexing for TXD0 function
```

UARTn's port RXD_n can be selected by PS_RXD_n (only one of the RXD_n pins can be selected), and the TXD_n port can be selected by the port configuration register (either at the same time or by selecting one of them). If selected at the same time, the corresponding waveform will be output).

When using, it is recommended to set the working mode first, and then configure the corresponding port as a serial port.

22.3 UARTn Baud Rate

UARTn In mode 0, the baud rate is fixed to the twelfth-way frequency of the system clock ($F_{sys}/12$); In mode 2, the baud rate is fixed to the system clock's division 32 or 64 ($F_{sys}/32$, $F_{sys}/64$); In modes 1 and 3, the baud rate is generated by the timer Timer1 or Timer4 or Timer2 or BRT module, and the chip chooses which timer to use as the baud rate clock source is determined by the register FUNCCR.

22.3.1 Baud Rate Clock Source

UARTn In mode 1 and mode 3, the baud rate clock source selection is as follows:

1) UART0 baud rate clock source selection:

FunccR [2:0] = 000, Timer1 is selected as the baud rate generator for UART0;

FunccR [2:0] = 001, Timer4 is selected as the baud rate generator for UART0;

FunccR [2:0] = 010, Select Timer2 as the baud rate generator for UART0;

FunccR [2:0] = 011, BRT is chosen as the baud rate generator for UART0.

2) UART1 baud rate clock source selection:

FunccR [6:4] = 000, Timer1 is selected as the baud rate generator for UART1;

FUNCCR[6:4]=001, Select Timer4 as the baud rate generator for UART1;

FUNCCR [6:4] = 010, Timer2 was selected as the baud rate generator for UART1;

FUNCCR [6:4] = 011, BRT was chosen as the baud rate generator for UART1.

22.3.2 Baud Rate Calculation

In mode 1 and mode 3, the baud rate calculation formula for different clock sources is as follows:

1) Timer1 or Timer4 works in 8-bit auto-reload mode with baud rate formula:

$$BaudRate = \frac{F_{sys} \times 2^{SMODn}}{32 \times (4 \times 3^{1-TxM}) \times (256 - THx)} \quad (x=1,4)$$

SMODn is the baud rate select bit and is set by the register PCON. T1M is the timer 1 clock select bit, set by register CKCON[4], T4M is the timer 4 clock select bit, set by register T34MOD[6]. i.e. the value of Timer1 or Timer4 at the corresponding baud rate TH1/TH4 should be set to:

$$THx = 256 - \frac{F_{sys} \times 2^{SMODn}}{32 \times (4 \times 3^{1-TxM}) \times BaudRate} \quad (x=1,4)$$

2) Timer2 works in the formula of baud rate in overflow auto Reload mode:

$$BaudRate = \frac{F_{sys} \times 2^{SMODn}}{32 \times (12 \times 2^{T2PS}) \times (65536 - \{RLDH, RLDL\})}$$

T2PS is a timer 2 clock prescaler selection bit set by register T2CON[7]. That is, the value of Timer2 at the corresponding baud rate should be set to: {RLDH, RLDL}

$$\{RLDH, RLDL\} = 65536 - \frac{F_{sys} \times 2^{SMODn}}{32 \times (12 \times 2^{T2PS}) \times BaudRate}$$

3) When BRT is used as a baud rate generator, the baud rate formula:

$$BaudRate = \frac{F_{sys} \times 2^{SMODn}}{32 \times (65536 - \{BRTDH, BRTDL\}) \times 2^{BRTCKDIV}}$$

BRTCKDIV is a BRT timer prescale selection bit, set by the register BRTCON. That is, the value of the BRT at the corresponding baud rate should be set to: {BRTDH, BRTDL}

$$\{BRTDH, BRTDL\} = 65536 - \frac{F_{sys} \times 2^{SMODn}}{32 \times 2^{BRTCKDIV} \times BaudRate}$$

22.3.3 Baud Rate Error

In mode 1 and mode 3, UARTn selects different baud rate clock sources, and the errors at different baud rates are as follows:

Table 1) and 2) are some of the baud rate information in the 8-bit automatic reload mode of timer 1/timer 4 in variable baud rate mode. Table 3) and 4) show the BRT timer overflow rate in variable baud rate mode as part of the baud rate information of the UART clock source.

1) SMODn=0, T1M=1/T4M=1

baud rate	Fsys=8MHz			Fsys=16MHz			Fsys=24MHz			Fsys=48MHz		
	{TH1, TH4}	Current Rate	% Error	{TH1, TH4}	Current Rate	% Error	{TH1, TH4}	Current Rate	% Error	{TH1, TH4}	Current Rate	% Error
4800	243	4808	-0.16	230	4808	-0.16	217	4808	-0.16	178	4808	-0.16
9600	--	--	--	247	9615	-0.16	236	9375	2.34	217	9615	-0.16
19200	--	--	--	--	--	--	246	18750	2.34	236	18750	2.34
38400	--	--	--	--	--	--	251	37500	2.34	246	37500	2.34
115200	--	--	--	--	--	--	--	--	--	--	--	--
250000	--	--	--	--	--	--	--	--	--	--	--	--
500000	--	--	--	--	--	--	--	--	--	--	--	--

2) SMODn=1, T1M=1/T4M=1

baud rate	Fsys=8MHz			Fsys=16MHz			Fsys=24MHz			Fsys=48MHz		
	{TH1, TH4}	Current Rate	% Error	{TH1, TH4}	Current Rate	% Error	{TH1, TH4}	Current Rate	% Error	{TH1, TH4}	Current Rate	% Error
4800	230	4808	-0.16	204	4808	-0.16	178	4808	-0.16	100	4808	-0.16
9600	243	9615	-0.16	230	9615	-0.16	217	9615	-0.16	178	9615	-0.16
19200	--	--	--	243	19230	-0.16	236	18750	2.34	217	19231	-0.16
38400	--	--	--	--	--	--	246	37500	2.34	236	37500	2.34
115200	--	--	--	--	--	--	--	--	--	--	--	--
250000	--	--	--	--	--	--	--	--	--	--	--	--
500000	--	--	--	--	--	--	--	--	--	--	--	--

3) SMODn=0, BRTCKDIV=0

baud rate	Fsys=8MHz			Fsys=16MHz			Fsys=24MHz			Fsys=48MHz		
	{BRTH, BRTL}	Current Rate	% Error	{BRTH, BRTL}	Current Rate	% Error	{BRTH, BRTL}	Current Rate	% Error	{BRTH, BRTL}	Current Rate	% Error
4800	65484	4808	-0.16	65432	4808	-0.16	65380	4808	-0.16	65224	4808	-0.16
9600	65510	9615	-0.16	65484	9615	-0.16	65458	9615	-0.16	65380	9615	-0.16
19200	65523	19231	-0.16	65510	19231	-0.16	65497	19231	-0.16	65458	19231	-0.16
38400	--	--	--	65523	38462	-0.16	65516	37500	2.34	65497	38462	-0.16
115200	--	--	--	--	--	--	--	--	--	65523	115385	-0.16
250000	--	--	--	--	--	--	--	--	--	65530	250000	0
500000	--	--	--	--	--	--	--	--	--	65533	500000	0

4) SMODn=1, BRTCKDIV=0

baud rate	Fsys=8MHz			Fsys=16MHz			Fsys=24MHz			Fsys=48MHz		
	{BRTH, BRTL}	Current Rate	% Error	{BRTH, BRTL}	Current Rate	% Error	{BRTH, BRTL}	Current Rate	% Error	{BRTH, BRTL}	Current Rate	% Error
4800	65432	4808	-0.16	65328	4808	-0.16	65224	4792	0.16	64911	4800	0
9600	65484	9615	-0.16	65432	9615	-0.16	65380	9615	-0.16	65224	9615	-0.16
19200	65510	19231	-0.16	65484	19231	-0.16	65458	19231	-0.16	65380	19231	-0.16
38400	65523	38462	-0.16	65510	38462	-0.16	65497	38462	-0.16	65458	38462	-0.16
115200	--	--	--	--	--	--	65523	115385	-0.16	65510	115385	-0.16
250000	--	--	--	--	--	--	--	--	--	65524	250000	0
500000	--	--	--	--	--	--	--	--	--	65530	500000	0
1000000	--	--	--	--	--	--	--	--	--	65533	1000000	0

22.4 UARTn Register

UARTn has the same functionality as the standard 8051 UART. Its Related Registers are: FUNCCR, SBUF_n, SCON_n, PCON, IE, IP. The UARTn Data Buffer (SBUF_n) consists of 2 independent registers: the transmit and receive registers. The data written to SBUF_n will be set in the UARTn output register and the transmission will begin; The data that reads SBUF_n will be read from the UARTn receive register. The SCON0 register supports bit addressing operations, and the SCON1 registers do not support bit addressing operations, so be aware when using assembly language. The baud rate is doubled by register PCON settings.

22.4.1 UART0/1 Baud Rate Selection Register FUNCCR

0x91	Bit7	Bit6	Bit5	Bit4	Bit3	Bit2	Bit1	Bit0
FUNCCR	--	UART1_CKS2	UART1_CKS1	UART1_CKS0	--	UART0_CKS2	UART0_CKS1	UART0_CKS0
R/W	R/W	R/W	R/W	R/W	R/W	R/W	R/W	R/W
Reset value	0	0	0	0	0	0	0	0

Registers in BANK0

- Bit7 -- Reserved, must be 0.
- Bit6-Bit4 UART1_CKS<2:0>: Timer clock source selection for UART1
- 000= Overflow clock for Timer1;
 - 001= Overflow clock for Timer4;
 - 010= Overflow clock for Timer2;
 - 011= BRT overflow clock;
 - Other = Forbidden Access.
- Bit3 -- Reserved, must be 0.
- Bit2-Bit0 UART0_CKS<2:0>: Timer clock source selection for UART0
- 000= Overflow clock for Timer1;
 - 001= Overflow clock for Timer4;
 - 010= Overflow clock for Timer2;
 - 011= BRT overflow clock;
 - Other = Forbidden Access.

22.4.2 UARTn Buffer Register SBUF_n

	Bit7	Bit6	Bit5	Bit4	Bit3	Bit2	Bit1	Bit0
SBUF _n	BUFFER _n 7	BUFFER _n 6	BUFFER _n 5	BUFFER _n 4	BUFFER _n 3	BUFFER _n 2	BUFFER _n 1	BUFFER _n 0
R/W	R/W	R/W	R/W	R/W	R/W	R/W	R/W	R/W
Reset value	X	X	X	X	X	X	X	X

BANK0: Register SBUF0 address 0x99; Register SBUF1 address 0xEB.

- Bit7~Bit0 BUFFER_n<7:0>: Buffered data registers.
- Write: UARTn started sending data.
 - Read: Reads the received data.

22.4.3 UART Control Register SCOn

	Bit7	Bit6	Bit5	Bit4	Bit3	Bit2	Bit1	Bit0
SCOn	UnSM0	UnSM1	UnSM2	UnREN	UnTB8	UnRB8	Believe	RIn
R/W	R/W	R/W	R/W	R/W	R/W	R/W	R/W	R/W
Reset value	0	0	0	0	0	0	0	0

BANK0: Register SCOn address 0x98; Register SCOn1 address 0xEA.

Bit7~Bit6	UnSM0- UnSM1:	Multi-Slave communication control bit; 00= Master synchronization mode; 01= 8-bit asynchronous mode, variable baud rate; 10= 9-bit asynchronous mode with baud rates of Fsys/32 or Fsys/64; 11= 9-bit asynchronous mode with variable baud rate.
Bit5	UnSM2:	Multi-Slave communication control bit; 1= Enable; 0= Disable.
Bit4	UnREN:	Receive enable bits; 1= Enable; 0= Disable.
Bit3	UnTB8:	The 9th bit of sending data, mainly used for sending in 9-bit asynchronous mode; 1= The 9th digit is 1; 0= The 9th digit is 0.
Bit2	UnRB8:	The 9th bit of receiving data, mainly used for sending in 9-bit asynchronous mode; 1= The 9th bit of data received is 1; 0= Bit 9 received is 0.
Bit1	TIn:	Send interrupt flag bits (requires software zeroing); 1= Indicates that the send buffer is empty, and you can send the frame data. 0= --
Bit0	RIn:	Receive interrupt flag bits (requires software zeroing); 1= Indicates that the receive buffer is full, and the next frame of data can be received after reading. 0= --

The UARTn schema is as follows:

SMn0	SMn1	mode	description	baud rate
0	0	0	Shift register	Fsys/12
0	1	1	8-Bit UART	Controlled by Timer4/Timer1/Timer2/BRT
1	0	2	9-Bit UART	SMODn=0: Fsys/64;SMODn=1: Fsys/32
1	1	3	9-Bit UART	Controlled by Timer4/Timer1/Timer2/BRT

22.4.4 PCON Registers

0x87	Bit7	Bit6	Bit5	Bit4	Bit3	Bit2	Bit1	Bit0
PCON	SMOD0	SMOD1	--	--	--	THEIR	STOP	IDLE
R/W	R/W	R/W	R/W	R/W	R/W	R/W	R/W	R/W
Reset value	0	0	0	0	0	0	0	0

Registers in BANK0

Bit7	SMOD0: UART0 baud rate multiplier; 1= UART0 baud rate doubled; 0= The UART0 baud rate is normal.
Bit6	SMOD1: UART1 baud rate multiplier; 1= Doubling the UART1 baud rate; 0= The UART1 baud rate is normal.
Bit5~Bit3	-- Reserved, must be 0.
Bit2	THEIR: STOP status function wake-up enable bit; (The system can be restarted by a power-down reset or an enabled external reset regardless of the SWE value) 0= Disables functional wake-up; 1= Enables function wake-up (wake-up by external interrupts and timed wake-ups).
Bit1	STOP: Sleep state control bit; 1= Enter the hibernation state (exit STOP mode to automatically clear zero); 0= Does not go into hibernation.
Bit0	IDLE: Idle state control bit; 1= Enter the idle state (exit THE IDLE mode to automatically clear the zero); 0= Not idle

22.5 UARTn Interrupt

The interrupt number of UART0 is 4, where the interrupt vector is 0x0023.

The interrupt number of UART1 is 6, where the interrupt vector is 0x0033.

To enable a UARTn interrupt, it must set its enable bit ESn to 1 and the global interrupt enable bit EA to 1. If the interrupt enables associated with UARTn are turned on, TIn=1 or RIn=1, the CPU will enter the corresponding interrupt service program. TIn/RIn is independent of the state of ESn and requires software zeroing, which describes the reference register SCOnn in detail.

22.5.1 Interrupt Mask Register IE

0xA8	Bit7	Bit6	Bit5	Bit4	Bit3	Bit2	Bit1	Bit0
IE	SHE	ES1	ET2	ES0	ET1	EX1	ET0	EX0
R/W	R/W	R/W	R/W	R/W	R/W	R/W	R/W	R/W
Reset value	0	0	0	0	0	0	0	0

Bit7	SHE: Global interrupt enable bits; 1= Enable all unblocked interrupts; 0= Disable all interrupts.
Bit6	ES1: UART1 interrupt enable bit; 1= Enable UART1 interrupt; 0= Disable UART1 Interrupt.
Bit5	ET2: TIMER2 Global interrupt Enable bits; 1= Enable all interrupts of TIMER2; 0= All interrupts of TIMER2 are Disabled.
Bit4	ES0: UART0 interrupt enable bit; 1= Enable UART0 interrupts; 0= Disable UART0 Interrupt.
Bit3	ET1: TIMER1 interrupt enable bit; 1= Enable TIMER1 interrupts; 0= Disable TIMER1 Interrupt.
Bit2	EX1: External interrupt 1 interrupt enable bits; 1= Enable external interrupt 1 interrupt; 0= Disable external interrupt 1 interrupt.
Bit1	ET0: TIMER0 interrupt enable bits; 1= Enable TIMER0 interrupts; 0= Disable TIMER0 Interrupts.
Bit0	EX0: External interrupt 0 interrupt enable bit; 1= Enable external interrupt 0 interrupts; 0= Disable external interrupt 0 interrupt.

22.5.2 Interrupt Priority Control Register IP

0xB8	Bit7	Bit6	Bit5	Bit4	Bit3	Bit2	Bit1	Bit0
IP	--	PS1	PT2	PS0	PT1	PX1	PT0	PX0
R/W	R/W	R/W	R/W	R/W	R/W	R/W	R/W	R/W
Reset value	0	0	0	0	0	0	0	0

Bit7	--	Reserved, must be 0.
Bit6	PS1:	UART1 interrupt priority control bit; 1= Set to High-level Interrupt; 0= Set to low-level interrupt.
Bit5	PT2:	TIMER2 interrupt priority control bit; 1= Set to High-level Interrupt; 0= Set to low-level interrupt.
Bit4	PS0:	UART0 interrupt priority control bit; 1= Set to High-level Interrupt; 0= Set to low-level interrupt.
Bit3	PT1:	TIMER1 interrupt priority control bit; 1= Set to High-level Interrupt; 0= Set to low-level interrupt.
Bit2	PX1:	External interrupt 1 interrupt priority control bit; 1= Set to High-level Interrupt; 0= Set to low-level interrupt.
Bit1	PT0:	TIMER0 interrupt priority control bit; 1= Set to High-level Interrupt; 0= Set to low-level interrupt.
Bit0	PX0:	External interrupt 0 interrupt priority control bit; 1= Set to High-level Interrupt; 0= Set to low-level interrupt.

22.6 UARTn Mode

22.6.1 Mode 0 - Synchronous Mode

Pin RXDn is the input or output and TXDn is the clock output. The TXDn output is a shift clock. The baud rate is fixed at 1/12 of the system clock frequency. 8 bits are transmitted preferentially with LSB. Initialize the receive by setting the flag in SCONn, set to: RIn = 0 and RENn = 1. The mode 0 timing diagram is shown in the following figure:

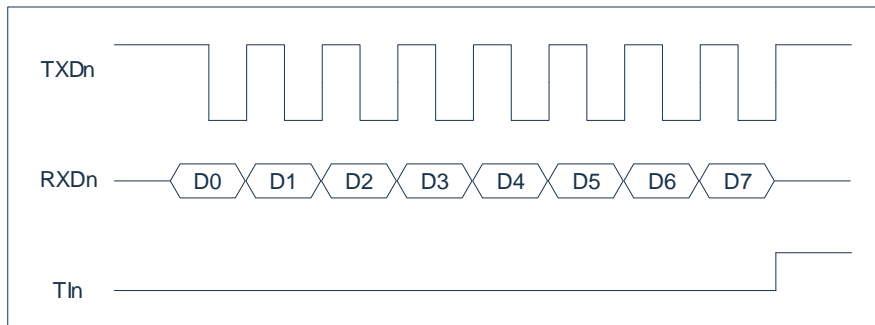

22.6.2 Mode 1-8 Bit Asynchronous Mode (Variable Baud Rate)

The pin RXDn is used as the input and the TXDn is used as the serial output. Send 10 bits: start bit (always 0), 8 bits of data (LSB first), and stop bit (always 1). When received, the start bit is transmitted synchronously, 8 data bits can be obtained by reading SBUFn, and the stop bit sets the flag RBn8 in SCONn. The baud rate is variable and depends on the TIMER1/TIMER2/TIMER4/BRT mode. The Mode 1 timing diagram is shown in the following figure:

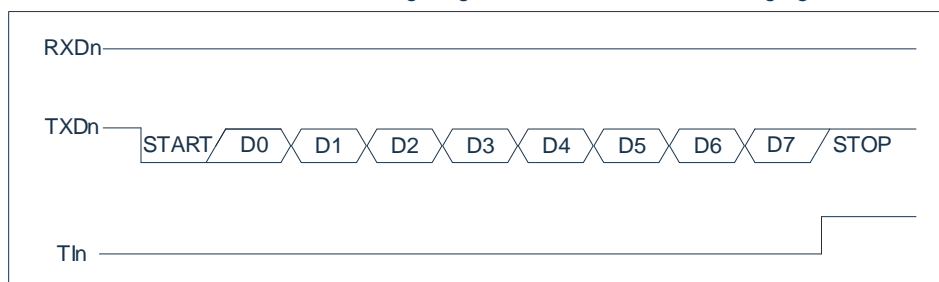

22.6.3 Mode 2-9 Bit Asynchronous Mode (Fixed Baud Rate)

This mode is similar to Mode 1, but differs in two ways. The baud rate is fixed at 1/32 or 1/64 of the CLK clock frequency, with 11 bits of transceiver: start bit (0), 8 bits of data (LSB first), programmable bit 9, and stop bit (1). Bit 9 can be used to control parity of the UARTn interface: at send time, bit TBn8 in SCONn acts as the 9th bit output, and on receive, bit 9 affects RBN8 in SCONn. The Mode 3 timing diagram is shown in the following figure:

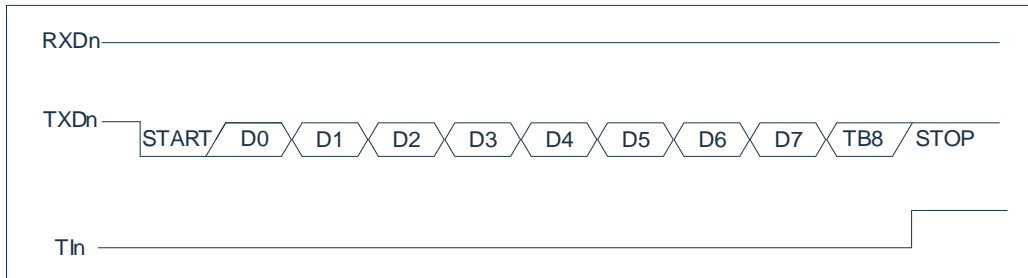

22.6.4 Mode 3-9 Bit Asynchronous Mode (Variable Baud Rate)

The only difference between mode 2 and mode 3 is that the baud rate in mode 3 is variable. When REN0=1, data reception is enabled. The baud rate is variable and depends on the TIMER1/TIMER2/TIMER4/BRT mode. The Mode 4 timing diagram is shown in the following figure:

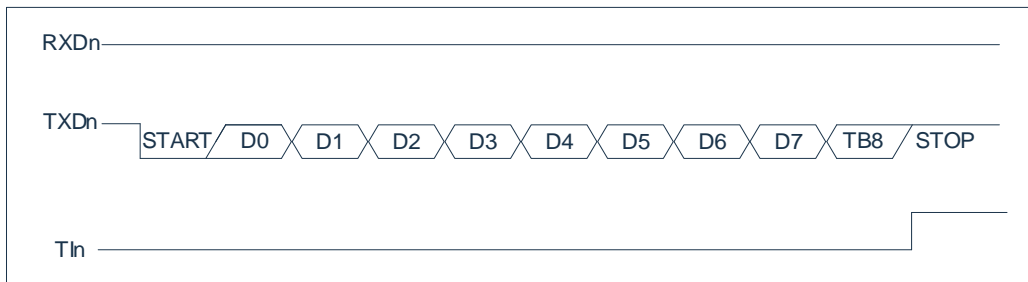

23. Analog-to-digital Converter (ADC)

23.1 Overview

An analog-to-digital converter (ADC) converts an analog input signal into a 12-bit binary number representing the signal, as shown in the ADC block diagram below.

The port analog input signal and the internal analog signal are connected to the input of the analog-to-digital converter after being multiplexed. The analog-to-digital converter uses successive approximation to produce a 12-bit binary result and saves the result in the ADC result register (ADRESL and ADRESH), and the ADC can generate an interrupt after the conversion is complete. The ADC conversion results are compared to the values of the ADC comparison data registers (ADCMPL and ADCPH), which are stored in the ADCPO flag bits.

The ADC reference voltage is always internally generated and can be provided with avdd or by an internal ADC-LDO.

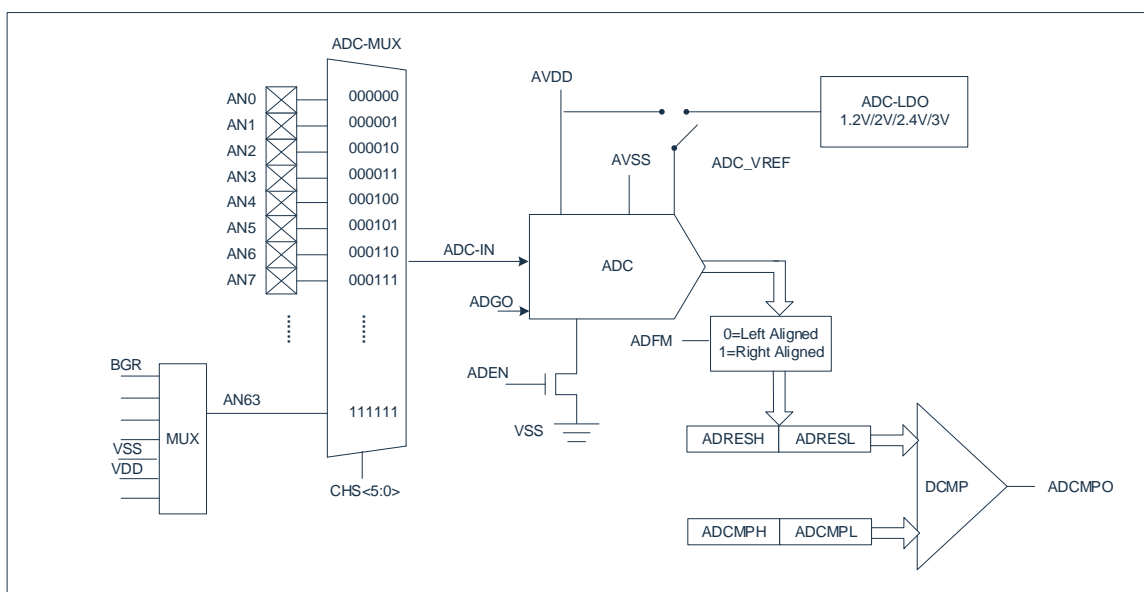

23.2 ADC Configuration

When configuring and using an ADC, the following factors must be considered:

- Port configuration.
- Channel selection.
- ADC converts the clock source.
- Interrupt control.
- The format in which the results are stored.

23.2.1 Port Configuration

ADC can convert both analog and digital signals. When converting an analog signal, the corresponding port needs to be configured as an analog port.

Note: Applying an analog voltage to a pin defined as a digital input may cause an overcurrent in the input buffer.

23.2.2 Channel Selection

The register ADCCHS bit determines which channel is connected to the analog-to-digital converter.

If you change the channel, you will need a delay before the next conversion starts. The ADC delay time is shown in the following table:

Delay time	Operating voltage
500ns	2.5~4.5V
200ns	4.5~5.5V

23.2.3 ADC Reference Voltage

The reference voltage for the ADC is provided by default by the chip's VDD or by the internal ADC-LDO. The ADC-LDO can choose from four voltage outputs: 1.2V/2.0V/2.4V/3.0V.

23.2.4 Convert the Clock

The converted clock source can be selected by software setting the ADCKS bit of the ADCON1 register.

The time to complete a bit conversion is defined as T_{ADCK} . A full 12-bit conversion takes 18.5 T_{ADCK} cycles (the time it takes to complete a conversion ADGO lasts high). The appropriate T_{ADCK} specification must be met to obtain the correct conversion results.

Note: Any change in the system clock frequency will change the frequency of the ADC clock, which can negatively affect the ADC conversion results.

23.2.5 Result Format

The results of the 12-bit A/D conversion can be in two formats: left-aligned or right-aligned. The output format is controlled by the ADFM bit of the ADCON0 register.

When ADFM=0, the AD conversion result is left-aligned;

When ADFM=1, the AD conversion result is right-aligned.

23.3 The ADC Hardware Trigger Start

In addition to software-triggered ADC conversion, the ADC module provides a way for hardware to trigger start. One is the external port edge triggering method, and the other is the edge or periodic triggering mode of the PWM.

Using a hardware trigger ADC requires setting ADCX to 1, even if the ADC function can be triggered externally. The hardware trigger signal will set the ADGO bit to 1 after a certain delay, and will be automatically cleared after conversion. After the hardware trigger function is enabled, the software trigger function is not disabled, and the AD conversion can be initiated by writing 1 to the ADGO bit when the ADC is idle.

23.3.1 The External Port Edge Triggers the ADC

The ADET pin edge automatically triggers the ADC conversion. At this point, ADTGS [1:0] needs to be 11 (select external port edge trigger), ADEGS [1:0] can choose which edge trigger.

23.3.2 PWM Triggers the ADC

The PWM can optionally trigger the ADC conversion by the edge or the zero point. ADTGS [1:0] Select the PWM channel (PG0, PG2, PG4), and ADEGS [1:0] can select the triggering method of edge type or period type.

23.3.3 Hardware Trigger Start Delay

After the hardware trigger signal is generated, the AD conversion is not started immediately, and it takes a certain delay before the ADGO is set to 1. The delay is determined by ADDLY [9:0]. The delay time of the hardware trigger signal: $(ADDLY+3)*T_{sys}$, the block diagram of the delayed trigger structure is shown in the following figure:

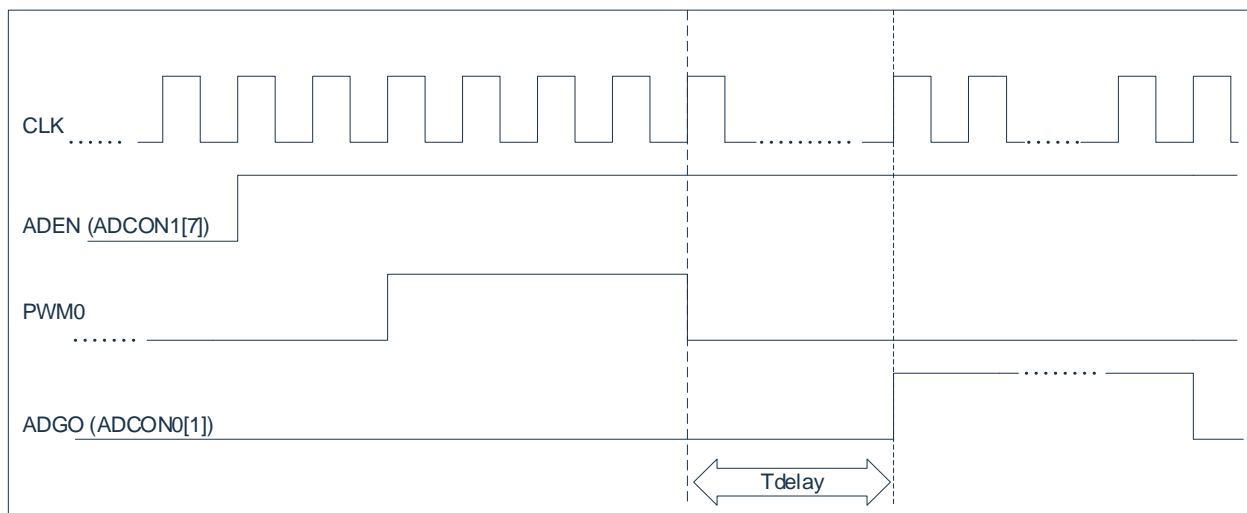

23.4 ADC Results Comparison

The ADC module provides a set of digital comparators for comparing the results of an ADC with the value size of preloaded {ADCMPL, ADCMPH}. The result of each ADC conversion is compared to the preset value ADCMP, and the result of the comparison is stored in the ADCPO flag bit, which is automatically updated after the conversion is completed. The ADCMPPS bit can change the polarity of the output result.

23.5 How the ADC Works

23.5.1 Start the Conversion

To enable the ADC module, you must first place ADEN bit set to 1 of the ADCON1 register, and then start the analog-to-digital conversion of ADGO bit set to 1 of the ADCON0 register (ADGO cannot be set to 1 if the ADEN is 0).

23.5.2 Complete the Conversion

When the conversion is complete, the ADC module will:

- Zero ADGO bit;
- Place the ADCIF flag at bit set to 1;
- Update the ADRESH:ADRESL register with the new result of the conversion.

23.5.3 Terminate the Conversion

If the conversion must be terminated before it is complete, the analog-to-digital conversion results that have not yet completed are not updated to the ADRESH:ADRESL register. Therefore, the ADRESH:ADRESL register will maintain the value obtained by the last conversion.

Note: A device reset forces all registers to enter a reset state. Therefore, the reset shuts down the ADC module and terminates any pending transitions.

23.5.4 A/D Conversion Steps

The configuration steps for analog-to-digital conversion using an ADC are as follows:

- 1) Port configuration:
 - Disable pin output drivers (see PxTRIS registers);
 - Configure the pins as analog input pins.
- 2) Configure the ADC interrupt (optional):
 - Clear the ADC interrupt flag bit;
 - Enable ADC interrupts;
 - Enable peripheral interrupts;
 - Enable global interrupts.
- 3) To configure the ADC module:
 - Select the ADC conversion clock;
 - Select the ADC input channel;

- Select the format of the result;
 - Start the ADC module.
- 4) Wait for the required acquisition time.
 - 5) Set ADGO to 1 to start the conversion.
 - 6) Wait for the ADC conversion to finish by one of the following methods:
 - Query ADGO bits;
 - Wait for the ADC to interrupt (interrupt Enabled).
 - 7) Read the ADC results.
 - 8) Zero out the ADC interrupt flag bit (this is required if interrupts are Enabled).

Note: If the user attempts to resume sequential code execution after waking the device from sleep mode, the global interrupt must be suppressed.

23.5.5 Go to Sleep During the Conversion Process

When the system enters hibernation, it is recommended that you wait for the ADC to complete the transition in progress before entering hibernation.

If you go hibernation during an ongoing conversion of the ADC, the conversion is terminated. The conversion operation needs to be restarted after waking up.

23.6 Related Registers

There are 11 main registers associated with AD conversion, namely:

- AD control registers ADCON0, ADCON1, ADCON2, ADCCHS, ADCLDO;
- Comparator control register ADCPC;
- Delay data register ADDLYL;
- AD result data register ADRSH/L;
- Comparator data register ADCCMPH/L.

23.6.1 AD Control Register ADCON0

0xDF	Bit7	Bit6	Bit5	Bit4	Bit3	Bit2	Bit1	Bit0
ADCON0	--	ADFM	ANACH3	ANACH2	ANACH1	ANACH0	ADGO	--
R/W	R/W	R/W	R/W	R/W	R/W	R/W	R/W	R/W
Reset value	0	0	0	0	0	0	0	0

Bit7	--	Reserved, must be 0.
Bit6	ADFM:	ADC conversion result format select bits; 1= Right alignment; 0= Left-aligned.
Bit5~Bit2	ANACH<3:0>:	ADC channel 63 input source select bit; 0000= BGR(1.2V); 0001= Reserved, prohibited use; 0010= Reserved, prohibited use; 0011= Reserved, prohibited use; 0100= Reserved, prohibited use; 0101= VSS (ADC Reference Area); 0110= Reserved, prohibited use; 0111= VDD (ADC default reference voltage). Other = Reserved, prohibited.
Bit1	ADGO:	ADC converts the start bit (ADEN must be 1 for this bit set to 1, otherwise the operation is invalid); 1= Write: Starts the ADC conversion, (the hardware also uses this bit set to 1 when the ADC is triggered); Read: The ADC is converting. 0= Write: Invalid. Read: ADC idle/converted; During the conversion of the ADC (ADGO=1), any software and hardware trigger signals are ignored.
Bit0	--	Reserved, must be 0.

23.6.2 AD Control Register ADCON1

0xDE	Bit7	Bit6	Bit5	Bit4	Bit3	Bit2	Bit1	Bit0
ADCON1	ADEN	ADCKS2	ADCKS1	ADCKS0	--	--	--	--
R/W	R/W	R/W	R/W	R/W	R/W	R/W	R/W	R/W
Reset value	0	1	0	0	0	0	0	0

Bit7	ADEN: ADC enable bit; 1= Enable ADC; 0= ADC is Disabled and does not consume operating current.
Bit6~Bit4	ADCKS<2:0>: ADC conversion clock select bits; 000= Fsys/2; 100= Fsys/32; 001= Fsys/4; 101= Fsys/64; 010= Fsys/8; 110= Fsys/128; 011= Fsys/16; 111= Fsys/256.
Bit3~Bit0	-- Reserved, must be 0.

23.6.3 AD Control Register ADCON2

0xE9	Bit7	Bit6	Bit5	Bit4	Bit3	Bit2	Bit1	Bit0
ADCON2	ADCEX	--	ADTGS1	ADTGS0	ADEGS1	ADEGS0	--	--
R/W	R/W	R/W	R/W	R/W	R/W	R/W	R/W	R/W
Reset value	0	0	0	0	0	0	0	0

Bit7	ADCEX: ADC hardware trigger enable bit; 1= Enable; 0= Disable.
Bit6	-- Reserved, must be 0.
Bit5~Bit4	ADTGS<1:0>: ADC hardware trigger source select bit; 00= PG0 (PWM0); 01= PG2 (PWM2); 10= PG4 (PWM4); 11= Port pin (ADET).
Bit3~Bit2	ADEGS<1:0>: ADC hardware trigger edge selection bit; 00= Falling edges; 01= Rising edge; 10= Reserved, prohibited use; 11= The zero point of the PWM cycle.
Bit1~Bit0	-- Reserved, must be 0.

23.6.4 AD Channel Selection Register ADCCHS

0xD9	Bit7	Bit6	Bit5	Bit4	Bit3	Bit2	Bit1	Bit0
ADCCHS	--	--	CHS5	CHS4	CHS3	CHS2	CHS1	CHS0
R/W	R/W	R/W	R/W	R/W	R/W	R/W	R/W	R/W
Reset value	0	0	0	0	0	0	0	0

Bit7	--	Reserved, must be 0.	
Bit5~Bit0	CHS<5:0>	Analog channel selection bits;	
	000000=	AIN0;	010000= AIN16;
	000001=	AIN1;	010001= AIN17;
	000010=	AIN2;	010010= AIN18;
	000011=	AIN3;	010011= AIN19;
	000100=	AIN4;	010100= Prohibited access;
	000101=	AIN5;	010101= Prohibited access;
	000110=	AIN6;	010110= Prohibited access;
	000111=	AIN7;	010111= Prohibited access;
	001000=	AIN8;	011000= Prohibited access;
	001001=	AIN9;	011001= Prohibited access;
	001010=	AIN10;	011010= Prohibited access;
	001011=	AIN11;	011011= Prohibited access;
	001100=	AIN12;	011100= Prohibited access;
	001101=	AIN13;	011101= Prohibited access;
	001110=	AIN14;	011110= Prohibited access;
	001111=	AIN15;	011111= Prohibited access;
			100000= Prohibited access;
			100001= Prohibited access;
			100010= Prohibited access;
			100011= Prohibited access;
			100100= Prohibited access;
			100101= Prohibited access;
			100110= Prohibited access;
			100111= AIN39;
			101000= AIN40;
			101001= AIN41;
			101010= AIN42;
			101011= AIN43;
			101100= AIN44;
			101101= Prohibited access;
			Other = Prohibited access;
			111111= See ADCON0.ANACH description.

23.6.5 AD Comparator Control Register ADCPC

0xD1	Bit7	Bit6	Bit5	Bit4	Bit3	Bit2	Bit1	Bit0
ADCMP	--	ADCMPPS	--	ADCMPPO	--	--	ADDLY9	ADDLY8
R/W	R/W	R/W	R/W	R/W	R/W	R/W	R/W	R/W
Reset value	0	0	0	0	0	0	0	0

Bit7 -- Reserved, must be 0.

Bit6 ADCMPPS: ADC comparator output polarity select bit;
 1= If ADRES < ADCMP, ADCPO=1;
 0= If ADRES > =ADCMP, then ADCMPPO=1.

Bit5 -- Reserved, must be 0.

Bit4 ADCMPPO: ADC comparator output bits.

This bit outputs the result of the ADC comparator output, which is updated each time the ADC conversion ends.

Bit3~Bit2 -- Reserved, must be 0.

Bit1~Bit0 ADDLY<9:8>: ADC hardware trigger delay data [9:8] bits.

23.6.6 AD Hardware Trigger Delay Data Register ADDLYL

0xD3	Bit7	Bit6	Bit5	Bit4	Bit3	Bit2	Bit1	Bit0
ADDLYL	ADDLY7	ADDLY6	ADDLY5	ADDLY4	ADDLY3	ADDLY2	ADDLY1	ADDLY0
R/W	R/W	R/W	R/W	R/W	R/W	R/W	R/W	R/W
Reset value	0	0	0	0	0	0	0	0

Bit7~Bit0 ADDLY<7:0>: ADC hardware trigger delay data is 8 bits lower.

23.6.7 AD Data Register High ADRESH, ADFM=0 (Left Aligned)

0xDD	Bit7	Bit6	Bit5	Bit4	Bit3	Bit2	Bit1	Bit0
ADRESH	ADRES11	ADRES10	ADRES9	ADRES8	ADRES7	ADRES6	ADRES5	ADRES4
R/W	R	R	R	R	R	R	R	R
Reset value	X	X	X	X	X	X	X	X

Bit7~Bit0 ADDRESS<11:4>: ADC result register bit.

Bits 11-4 of the 12-bit conversion result.

23.6.8 AD Data Register Low ADRESL, ADFM=0 (Left Aligned)

0xDC	Bit7	Bit6	Bit5	Bit4	Bit3	Bit2	Bit1	Bit0
ADRESL	ADRES3	ADRES2	ADRES1	ADRES0	--	--	--	--
R/W	R	R	R	R	--	--	--	--
Reset value	X	X	X	X	--	--	--	--

Bit7~Bit4 ADDRESS<3:0>: ADC result register bit.

Bits 3-0 of the 12-bit conversion result.

Bit3~Bit0 Unused.

23.6.9 AD Data Register High ADRESH, ADFM=1 (Right-aligned)

0xDD	Bit7	Bit6	Bit5	Bit4	Bit3	Bit2	Bit1	Bit0
ADRESH	--	--	--	--	ADRES11	ADRES10	ADRES9	ADRES8
R/W	--	--	--	--	R	R	R	R
Reset value	--	--	--	--	X	X	X	X

Bit7~Bit4 Unused.

Bit3~Bit0 ADDRESS<11:8>: ADC result register bit.
Bits 11-8 of the 12-bit conversion result.

23.6.10 AD Data Register Low ADRSL, ADFM = 1 (Right-aligned)

0xDC	Bit7	Bit6	Bit5	Bit4	Bit3	Bit2	Bit1	Bit0
ADRSL	ADRES7	ADRES6	ADRES5	ADRES4	ADRES3	ADRES2	ADRES1	ADRES0
R/W	R	R	R	R	R	R	R	R
Reset value	X	X	X	X	X	X	X	X

Bit7~Bit0 ADDRESS<7:0>: ADC result register bit.
12 bits converted to bits 7-0 of the result.

23.6.11 AD Comparator Data Register ADCCMPH

0xD5	Bit7	Bit6	Bit5	Bit4	Bit3	Bit2	Bit1	Bit0
ADCCMPH	D11	D10	D9	D8	D7	D6	D5	D4
R/W	R/W	R/W	R/W	R/W	R/W	R/W	R/W	R/W
Reset value	1	1	1	1	1	1	1	1

Bit7~Bit0 ADCMP<11:4>: The ADC comparator data is 8 bits high.

23.6.12 AD Comparator Data Register ADCOP

0xD4	Bit7	Bit6	Bit5	Bit4	Bit3	Bit2	Bit1	Bit0
ADCMPH	--	--	--	--	D3	D2	D1	D0
R/W	R/W	R/W	R/W	R/W	R/W	R/W	R/W	R/W
Reset value	1	1	1	1	1	1	1	1

Bit7~Bit4 Unused.

Bit3~Bit0 ADCMP<3:0>: The ADC comparator data is 4 bits lower.

23.6.13 AD Reference Voltage Control Register

F692H	Bit7	Bit6	Bit5	Bit4	Bit3	Bit2	Bit1	Bit0
ADCLDO	LDOEN	VSEL1	VSEL0	--	--	--	--	--
R/W	R/W	R/W	R/W	R/W	R/W	R/W	R/W	R/W
Reset value	0	0	0	0	0	0	0	0

- Bit7 LDOEN ADC_LDO enabled;
 1= LDO enable, the reference voltage can only select the voltage corresponding to VSEL [1:0];
 0= LDO prohibits, the reference voltage is the chip supply voltage.
- Bit6~Bit5 VSEL<1:0>: ADC reference voltage selection bit;
 00= 1.2V ;
 01= 2.0V ;
 10= 2.4V ;
 11= 3.0V .
- Bit4 -- Reserved, must be 0.
- Bit3~Bit0 -- Reserved, must be 0.

23.7 ADC Interrupt

The ADC module allows an interrupt to be generated after the analog-to-digital conversion is complete. The ADC interrupt enable bit is the ADCIE bit in the EIE2 register, and the ADC interrupt flag bit is the ADCIF bit in the EIF2 register. The ADCIF bit must be cleared with software, and the ADCIF bit is set to 1 after each conversion, regardless of whether the ADC interrupt is Enabled. The interrupt enable and priority of the ADC can be set by the following relevant register bits.

23.7.1 Interrupt Mask Register EIE2

0xAA	Bit7	Bit6	Bit5	Bit4	Bit3	Bit2	Bit1	Bit0
EIE2	SPIIE	I2CIE	WDTIE	ADCIE	PWMIE	--	ET4	ET3
R/W	R/W	R/W	R/W	R/W	R/W	R/W	R/W	R/W
Reset value	0	0	0	0	0	0	0	0

- Bit7 SPIIE: SPI interrupt enable bit;
 1= Enable SPI interrupts;
 0= Disable SPI Interrupt.
- Bit6 I2CIE: I2C interrupt enable bit;
 1= Enable I2C interrupts;
 0= Forbidden I²C Interrupt.
- Bit5 WDTIE: WDT interrupt enable bit;
 1= Enable WDT overflow interrupts;
 0= Disable WDT overflow interrupts.
- Bit4 ADCIE: ADC interrupt enable bit;
 1= Enable ADC interrupts;
 0= Disable ADC interrupts.
- Bit3 PWMIE: PWM global interrupt enable bit;
 1= Enable all PWM interrupts;
 0= Disable all PWM interrupts.
- Bit2 -- Reserved, must be 0.
- Bit1 ET4: Timer4 interrupt enable bit;
 1= Enable Timer4 interrupts;
 0= Forbidden Timer4 Interrupt.
- Bit0 ET3: Timer3 interrupt enable bit;
 1= Enable Timer3 interrupts;
 0= Forbidden Timer3 Interrupt.

23.7.2 Interrupt Priority Control Register EIP2

0xBA	Bit7	Bit6	Bit5	Bit4	Bit3	Bit2	Bit1	Bit0
EIP2	PSPI	PI2C	PWDT	PADC	PPWM	PLED	PT4	PT3
R/W	R/W	R/W	R/W	R/W	R/W	R/W	R/W	R/W
Reset value	0	0	0	0	0	0	0	0

Bit7	PSPI: SPI interrupt priority control bit; 1= Set to High-level Interrupt; 0= Set to low-level interrupt.
Bit6	PI2C: I2C interrupt priority control bit; 1= Set to High-level Interrupt; 0= Set to low-level interrupt.
Bit5	PWDT: WDT interrupt priority control bit; 1= Set to High-level Interrupt; 0= Set to low-level interrupt.
Bit4	PADC: ADC interrupt priority control bit; 1= Set to High-level Interrupt; 0= Set to low-level interrupt.
Bit3	PPWM: PWM interrupt priority control bit 1= Set to High-level Interrupt; 0= Set to low-level interrupt.
Bit2	PLED: LED dot matrix scan interrupt priority control bit 1= Set to High-level Interrupt; 0= Set to low-level interrupt.
Bit1	PT4: TIMER4 interrupt priority control bit; 1= Set to High-level Interrupt; 0= Set to low-level interrupt.
Bit0	PT3: TIMER3 interrupt priority control bit; 1= Set to High-level Interrupt; 0= Set to low-level interrupt.

23.7.3 Peripheral Interrupt Flag Bit Register EIF2

0xB2	Bit7	Bit6	Bit5	Bit4	Bit3	Bit2	Bit1	Bit0
EIF2	SPIIF	I2CIF	--	ADCIF	PWMIF	--	TF4	TF3
R/W	R	R	--	R/W	R	--	R/W	R/W
Reset value	0	0	0	0	0	0	0	0

- Bit7 SPIIF: SPI global interrupt indicator bit, read-only;
 1= SPI generates an interrupt, (this bit is automatically cleared after the specific interrupt flag is cleared);
 0= The SPI did not produce an interrupt.
- Bit6 I2CIF: I2C global interrupt indicator bit, read-only;
 1= I2C produces an interrupt, (after clearing the specific interrupt flag, this bit is automatically cleared);
 0= I2C did not produce an interrupt.
- Bit5 -- Reserved, must be 0.
- Bit4 ADCIF: ADC interrupt flag bit;
 1= ADC conversion is completed, and software zeroing is required;
 0= The ADC conversion was not completed.
- Bit3 PWMIF: PWM global interrupt indicator bit, read-only;
 1= PWM generates an interrupt, (after the specific interrupt flag is cleared, this bit is automatically cleared);
 0= The PWM did not produce an interrupt.
- Bit2 -- Reserved, must be 0.
- Bit1 TF4: Timer4 timer overflow interrupt flag bit;
 1= Timer4 timer overflow, the hardware is automatically cleared when entering the interrupt service program, and the software can also be cleared;
 0= The Timer4 timer has no overflow.
- Bit0 TF3: Timer3 timer overflow interrupt flag bit;
 1= Timer3 timer overflow, when entering the interrupt service program, the hardware is automatically cleared, and the software can also be cleared;
 0= The Timer3 timer has no overflow.

24. Touch Module (TOUCH)

The touch module is an integrated circuit designed to realize the human touch interface, which can replace the mechanical light touch button to achieve waterproof and dustproof, sealed isolation, strong and beautiful operation interface.

Technical parameters:

- ◆ Up to 26 touch buttons are available.
- ◆ No external touch capacitors are required.
- ◆ The effective touch response time is less than 100ms.

24.1 Touch Module Usage Considerations

- ◆ The ground wire of the touch button detection part should be connected separately into a separate ground, and then a point should be connected to the common ground of the whole machine.
- ◆ Avoid high-voltage, high-current, high-frequency operation of the motherboard and touch circuit board overlapping placement. If this cannot be avoided, it should be kept as far away from the period area of high voltage and high current or shielded on the motherboard.
- ◆ The connection from the sensor disk to the touch chip is as short and thin as possible, if the PCB process allows for a line width of 0.1mm as much as possible.
- ◆ The connection from the sensor disk to the touch chip should not cross the signal line with strong interference and high frequency.
- ◆ Do not take other signal lines around the connection line from the sensor disk to the touch chip around 0.5mm.

25. Flash Memory

25.1 Overview

Flash memory contains program memory (APROM/BOOT) and nonvolatile data memory (Data FLASH). The maximum memory space of the program is 16KB, divided into 32 sectors, each containing 512B. The maximum data memory space is 1KB, which is divided into 2 sectors, each containing 512B.

The FLASH memory can be accessed by the associated special function register (SFR) to achieve IAP function, and the program space can also be CRC checked by the special function register (SFR). The SFR registers used to access the FLASH space are as follows:

- MLOCK
- MDATA
- MADRL
- MADRH
- PCRCDL
- PCRCDH
- MCTRL

MLOCK registers are used to enable memory operation, MDATA registers form a byte to hold 8 bits of data to be read/written, MADRL/MADRH registers hold the address of the accessed MDATA unit or the address of CRC checksum, PCRCDL/PCRCDH registers are used to maintain the running results of the program CRC, and MCTRL registers are used for memory operation control.

The memory module interface allows the memory to be read/written/erased. The memory allows byte reads and writes, and the write time is controlled by the on-chip timer, which ensures that the data in that address has been erased before writing new data. The write and erase voltages are generated by an on-chip charge pump that is rated for operation within the voltage range of the device for byte operation.

Flash memory erase operations only support sector erasure, not byte erasure. Before modifying the data for an address, it is recommended that you save other data before erasing the current sector and finally writing the data.

The chip supports CRC checking of program space codes, which are generated using the polynomial $CRC16-CCITT 'X^{16}+X^{12}+X^5+1'$.

25.2 Related Registers

25.2.1 Flash Protect Lock Register MLOCK

0xFB	Bit7	Bit6	Bit5	Bit4	Bit3	Bit2	Bit1	Bit0
MLOCK	MLOCK7	MLOCK6	MLOCK5	MLOCK4	MLOCK3	MLOCK2	MLOCK1	MLOCK0
R/W	In	In	In	In	In	In	In	In
Reset value	0	0	0	0	0	0	0	0

Bit7~Bit0 MLOCK<7:0>: memory operation enable bit (this register only supports write operations);
 AAH= Allows memory-related R/W/E operation;
 00H/FFH= Operation is not allowed;
 Other = Writes are prohibited.

Modify the sequence of instructions required by MLOCK (no other instructions can be inserted in the middle):

MOV	TA,#0AAH
MOV	TA,#055H
MOV	MLOCK,#0AAH

25.2.2 FLASH Memory Data Register MDATA

0xFE	Bit7	Bit6	Bit5	Bit4	Bit3	Bit2	Bit1	Bit0
MDATA	MDATA7	MDATA6	MDATA5	MDATA4	MDATA3	MDATA2	MDATA1	MDATA0
R/W	R/W	R/W	R/W	R/W	R/W	R/W	R/W	R/W
Reset value	X	X	X	X	X	X	X	X

Bit7~Bit0 MDATA<7:0>: Data that is read or written to program memory.

25.2.3 FLASH Memory Address Register MADRL

0xFC	Bit7	Bit6	Bit5	Bit4	Bit3	Bit2	Bit1	Bit0
MADRL	MADRL7	MADRL6	MADRL5	MADRL4	MADRL3	MADRL2	MADRL1	MADRL0
R/W	R/W	R/W	R/W	R/W	R/W	R/W	R/W	R/W
Reset value	0	0	1	1	1	1	1	1

Bit7~Bit0 MADRL<7:0>: Specifies that the address of the memory read/write operation is 8 bits lower.

25.2.4 FLASH Memory Address Register MADRH

0xFD	Bit7	Bit6	Bit5	Bit4	Bit3	Bit2	Bit1	Bit0
MADRH	MADRH7	MADRH6	MADRH5	MADRH4	MADRH3	MADRH2	MADRH1	MADRH0
R/W	R/W	R/W	R/W	R/W	R/W	R/W	R/W	R/W
Reset value	0	0	0	0	0	0	0	0

Bit7~Bit0 MADRH<7:0>: Specifies that the address of the memory read/write operation is 8 bits high.

25.2.5 Program CRC Operation Result Data Register Lower 8-bit PCRCDL

0xF9	Bit7	Bit6	Bit5	Bit4	Bit3	Bit2	Bit1	Bit0
PCRCDL	PCRCDL<7:0>							
R/W	R/W	R/W	R/W	R/W	R/W	R/W	R/W	R/W
Reset value	0	0	0	0	0	0	0	0

Bit7~Bit0 PCRCDL<7:0> The program CRC operation results 8 bits lower data

25.2.6 Program CRC Operation Result Data Register Higher 8-bit PCRCDH

0xFA	Bit7	Bit6	Bit5	Bit4	Bit3	Bit2	Bit1	Bit0
PCRCDH	PCRCDH<15:8>							
R/W	R/W	R/W	R/W	R/W	R/W	R/W	R/W	R/W
Reset value	0	0	0	0	0	0	0	0

Bit7~Bit0 PCRCDH<15:8> The program CRC operation results in 8 bits of data high

25.2.7 FLASH Memory Control Register MCTRL

0xFF	Bit7	Bit6	Bit5	Bit4	Bit3	Bit2	Bit1	Bit0
MCTRL	--	--	TAKE	MREG	MMODE1	MMODE0	CRCADR	MSTART
R/W	R	R	R/W	R/W	R/W	R/W	R/W	R/W
Reset value	1	0	0	1	0	0	0	0

- Bit7~Bit6 -- Retain.
- Bit5 TAKE: Operation error flag bit (write 0 cleared);
 1= Before the programming operation begins, the data in the detection programming address is not "FFH" (not erased) and the write operation terminates immediately.
 0= --
- Bit4 MREG: Flash area selection bits;
 1= Select the data area (low 10-bit address is valid);
 0= Select the program area (low 14-bit address is valid).
- Bit3~Bit2 MMODE<1:0>: Operating mode selection bit:
 11= Erase operation mode (the scope of the erase operation is: the entire sector where the current address is located);
 10= Write operation mode;
 01= CRC mode;
 00= Read mode of operation.
- Bit1 CRCADR: Program CRC check address selection bit;
 1= End address select bit;
 0= Select the bit for the start address.
- Bit0 MSTART: Operation start control bit;
 1= Start the program memory R/W/E/CRC check operation (after the operation is completed, it can be automatically cleared by the hardware);
 0= Write: Terminate or do not start the program memory R/W/E/CRC check operation;
 Read: The operation completed or the operation did not start.

Note: The CRCADR must be cleared after the CRC is finished.

25.3 Feature Description

During flash memory read/write/erase operations, the CPU is in a paused state, and when the operation is complete, the CPU continues to run instructions.

The operation memory instruction must be followed by 6 NOP instructions, for example:

```
MOV MCTRL,#09H                ; The write operation begins
NOP
NOP
NOP
NOP
NOP
NOP
MOV MCTRL,#01H                ; The read operation begins
NOP
NOP
NOP
NOP
NOP
NOP
```

The program CRC check command is set by the register MCTRL [3:2], the start and end addresses are freely configurable through the registers MADRL/MADRH, and the results are saved in the register PCRCDL/PCRCDH.

This CRC operation can only access the program storage space, and the data storage space cannot be accessed. During the program space CRC check, the CPU stops working and waits for the CPU to continue running after the CRC calculation is complete. The CRC check is checked byte by byte, from the initial address to the end address, and after performing the current CRC check, you need to set the MMODE [1:0]=00 of MCTRL. The CRC check procedure is as follows:

- 1) Enable access to program memory registers:
TA = 0xAA;
TA = 0x55;
MLOCK=0xAA; The default value is 00
- 2) Check the results before clearing the program CRC:
PCRCDL=0x00;PCRCDH=0x00.
- 3) Set the program CRC check start and end addresses:
MCTRL[1]=0, set the starting address by MADRL/MADRH;
MCTRL[1]=1, with the end address set via MADRL/MADRH.
- 4) Start the program CRC check command:
MCTRL=0x05.
- 5) Wait for the program CRC check to end:
After the CRC check is complete, the MCTRL[0] hardware clears 0.
- 6) Read the program CRC check result:
PCRCDL stores the lower 8 bits CRC operation result of the program;
PCRCDH stores the higher 8 bits CRC operation result of the program.
- 7) The CRC check end address selection bit is cleared to 0.
MCTRL[1] is cleared to 0 by software after the CRC check.

26. Unique ID (UID)

26.1 Overview

Each chip has a different 96-bit unique identification number, or Unique identification. It has been set at the factory and cannot be modified by the user.

26.2 UID Register Description

UID0

F5E0H	Bit7	Bit6	Bit5	Bit4	Bit3	Bit2	Bit1	Bit0
UID0	UID7	UID6	UID5	UID4	UID3	UID2	UID1	UID0
R/W	R	R	R	R	R	R	R	R
Reset value	X	X	X	X	X	X	X	X

Bit7~Bit0 UID<7:0>

UID1

F5E1H	Bit7	Bit6	Bit5	Bit4	Bit3	Bit2	Bit1	Bit0
UID1	UID15	UID14	UID13	UID12	UID11	UID10	UID9	UID8
R/W	R	R	R	R	R	R	R	R
Reset value	X	X	X	X	X	X	X	X

Bit7~Bit0 UID<15:8>

UID2

F5E2H	Bit7	Bit6	Bit5	Bit4	Bit3	Bit2	Bit1	Bit0
UID2	UID23	UID22	UID21	UID20	UID19	UID18	UID17	UID16
R/W	R	R	R	R	R	R	R	R
Reset value	X	X	X	X	X	X	X	X

Bit7~Bit0 UID<23:16>

UID3

F5E3H	Bit7	Bit6	Bit5	Bit4	Bit3	Bit2	Bit1	Bit0
UID3	UID31	UID30	UID29	UID28	UID27	UID26	UID25	UID24
R/W	R	R	R	R	R	R	R	R
Reset value	X	X	X	X	X	X	X	X

Bit7~Bit0 UID<31:24>

UID4

F5E4H	Bit7	Bit6	Bit5	Bit4	Bit3	Bit2	Bit1	Bit0
UID4	UID39	UID38	UID37	UID36	UID35	UID34	UID33	UID32
R/W	R	R	R	R	R	R	R	R
Reset value	X	X	X	X	X	X	X	X

Bit7~Bit0 UID<39:32>

UID5

F5E5H	Bit7	Bit6	Bit5	Bit4	Bit3	Bit2	Bit1	Bit0
UID5	UID47	UID46	UID45	UID44	UID43	UID42	UID41	UID40
R/W	R	R	R	R	R	R	R	R
Reset value	X	X	X	X	X	X	X	X

Bit7~Bit0 UID<47:40>

UID6

F5E6H	Bit7	Bit6	Bit5	Bit4	Bit3	Bit2	Bit1	Bit0
UID6	UID55	UID54	UID53	UID52	UID51	UID50	UID49	UID48
R/W	R	R	R	R	R	R	R	R
Reset value	X	X	X	X	X	X	X	X

Bit7~Bit0 UID<55:48>

UID7

F5E7H	Bit7	Bit6	Bit5	Bit4	Bit3	Bit2	Bit1	Bit0
UID7	UID63	UID62	UID61	UID60	UID59	UID58	UID57	UID56
R/W	R	R	R	R	R	R	R	R
Reset value	X	X	X	X	X	X	X	X

Bit7~Bit0 UID<63:56>

UID8

F5E8H	Bit7	Bit6	Bit5	Bit4	Bit3	Bit2	Bit1	Bit0
UID8	UID71	UID70	UID69	UID68	UID67	UID66	UID65	UID64
R/W	R	R	R	R	R	R	R	R
Reset value	X	X	X	X	X	X	X	X

Bit7~Bit0 UID<71:64>

UID9

F5E9H	Bit7	Bit6	Bit5	Bit4	Bit3	Bit2	Bit1	Bit0
UID9	UID79	UID78	UID77	UID76	UID75	UID74	UID73	UID72
R/W	R	R	R	R	R	R	R	R
Reset value	X	X	X	X	X	X	X	X

Bit7~Bit0 UID<79:72>

UID10 (0xF5EA)

F5EAH	Bit7	Bit6	Bit5	Bit4	Bit3	Bit2	Bit1	Bit0
UID10	UID87	UID86	UID85	UID84	UID83	UID82	UID81	UID80
R/W	R	R	R	R	R	R	R	R
Reset value	X	X	X	X	X	X	X	X

Bit7~Bit0 UID<87:80>

UID11

F5EBH	Bit7	Bit6	Bit5	Bit4	Bit3	Bit2	Bit1	Bit0
UID11	UID95	UID94	UID93	UID92	UID91	UID90	UID89	UID88
R/W	R	R	R	R	R	R	R	R
Reset value	X	X	X	X	X	X	X	X

Bit7~Bit0 UID<95:88>

27. User Configuration

The System Configuration Register (CONFIG) is a FLASH option for the initial conditions of the MCU and cannot be accessed or operated by the program. It contains the following:

1. WDT (Watchdog Working Method Selection)
 - ENABLE Force open WDT
 - SOFTWARE CONTROL (default) The WDT operation is controlled by the WDTRE bit of the WDCON register
2. PROTECT
 - ENABLE The FLASH code is encrypted, and the code read out is 00H. And it is forbidden to enter debug mode
 - DISABLE (default) Flash code is not encrypted
3. FLASH_DATA_PROTECT
 - DISABLE Flash data areas are not encrypted
 - ENABLE (default) The FLASH data area is encrypted, and the value read out by the flashing emulator after encryption is 00H
4. LVR (Low Voltage Reset)
 - 1.8V (default)
 - 2.0V
 - 2.5V
 - 3.5V
5. DEBUG (debug mode)
 - DISABLE (default) Debug mode prohibits, DSCK, DSDA pins are used as ordinary IO ports
 - ENABLE Debug mode enables, DSCK, DSDA pins are configured as debug ports, and other functions corresponding to the pins are disabled
6. OSC (oscillation mode)
 - HSI (default) 48MHz
 - HSE
 - LSE(32.768KHz)
 - LSI(125KHz) 125KHz
7. HSELSE_SEL (crystal oscillation port oscillation method is selected).
 - OSCIN/OSCOUT AS HSE The HSE port is OSCIN/OSCOUT
 - OSCIN/OSCOUT AS LSE The LSE port is OSCIN/OSCOUT
 - NONE not
8. SYS_PRESCALE (system clock prescale selection)
 - $F_{osc}/1$ (default).
 - $F_{osc}/2$
 - $F_{osc}/4$
 - $F_{osc}/8$
9. HSI_FS (internal RC oscillator crossover selection)
 - $F_{HSI}/1$ 48MHz
 - $F_{HSI}/2$ 24MHz
 - $F_{HSI}/3$ 16MHz
 - $F_{HSI}/6$ (default). 8MHz

10. EXT_RESET (external reset configuration)

- | | |
|-----------------------|---|
| ● DISABLE (default) | External reset prohibits |
| ● ENABLE | External reset enable |
| ● ENABLE(OPEN PULLUP) | An external reset is enabled and the internal pull-up resistor of the reset port is turned on |

11. WAKE_UP_WAIT TIME (sleep wake-up waits for oscillator to stabilize by default to 1.0s)

- | | |
|---------|------------------|
| ● 50us | ● 5ms |
| ● 100us | ● 10ms |
| ● 500us | ● 500ms |
| ● 1ms | ● 1.0s (default) |

12. CPU_WAITCLOCK (memory wait clock selection)

- 1*System Clock (1T) (default)
- 2*System Clock (2T)
- 3*System Clock (3T)
- 4*System Clock (4T)
- 5*System Clock (5T)
- 6*System Clock (6T)
- 7*System Clock (7T)
- 8*System Clock (8T)

13. WRITE_PROTECT program partition protection (protectable areas, all default intervals are unprotected)

- 0000H-07FFH (Protected/Unprotected)
- 0800H-0FFFH (Protected/Unprotected)
- 1000H-17FFH (Protected/Unprotected)
- 1800H-1FFFH (Protected/Unprotected)
- 2000H-27FFH (Protected/Unprotected)
- 2800H-2FFFH (Protected/Unprotected)
- 3000H-37FFH (Protected/Unprotected)
- 3800H-3FFFH (Protected/Unprotected)

14. BOOT (BOOT Space Selection).

- | | |
|----------------------|-----------------------------|
| ● BOOT_DIS (default) | The BOOT zone is prohibited |
| ● BOOT_1K | The BOOT area space is 1K |
| ● BOOT_2K | The BOOT area space is 2K |
| ● BOOT_4K | The boot area space is 4K |

Note:

- 1) The machine cycle is related to the memory wait clock selection (CPU_WAITCLOCK): the machine cycle = $T_{SYS}/CPU_WAITCLOCK$.
- 2) When the oscillation mode is selected as HSI, the internal RC oscillator is selected as FHSI/1, and the system clock prescale is selected as $F_{OSC}/1$, and all three conditions are met, if the memory wait clock is selected as 1*System Clock (1T), the actual memory wait clock is selected as 2T, and the machine cycle = $T_{SYS}/2$.

28. In-circuit Programming and Debugging

28.1 Online Programming Mode

The chip can be programmed serially in the end application circuit. Programming can be done simply by the following 4 wires:

- Power cord
- Ground wire
- Data cable
- Clock line

In-line serial programming allows users to manufacture circuit boards using unprogrammed devices and program the chip only before product delivery, allowing the latest version of firmware or custom firmware to be programmed into the chip. A typical online serial programming connection method is shown in the following figure:

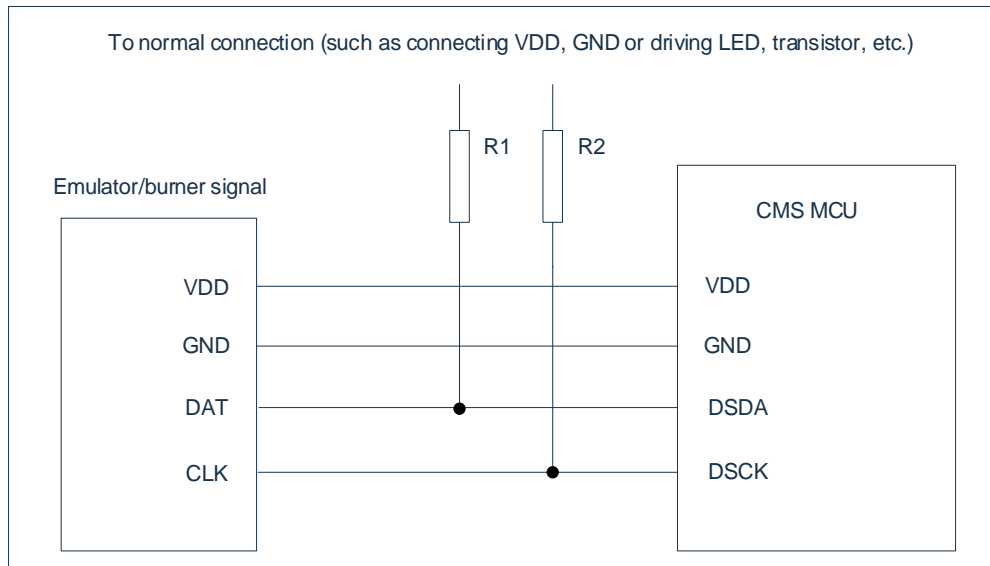

In the figure above, R1 and R2 are galvanical isolation devices, often replaced by resistors, and their resistance values are as follows: $R1 \geq 4.7K$, $R2 \geq 4.7K$.

Note that DSDA disables the connection of pull-down resistors during programming and debugging. If the actual circuit needs to be connected to the pull-down resistor, it is recommended to use the jumper structure to disconnect the pull-down resistor during programming/debugging, and then plug in the pull-down resistor after completion.

28.2 Online Debug Mode

The chip supports 2-wire (DSCK, DSDA) in-circuit debugging. If you use the in-circuit debugging function, you need to set DEBUG in the system configuration register to ENABLE. When using debug mode, you need to be aware of the following points:

- ◆ Under the debug state, the DSCK and DSDA ports are dedicated debug ports and cannot implement their GPIO and multiplexing functions.
- ◆ When the debug state enters sleep mode/idle mode, the system power supply and oscillator do not stop working, and the sleep wake function can be simulated in this state. If you need to focus on power consumption, it is recommended to turn off the debug function and then test the actual sleep current of the chip.
- ◆ Pauses in debug state, other functional peripherals continue to run, and the WDT, Timer0/1/2/3/4 counters stop. However, if Timer1/4 is used as the baud rate generator for UART0/1, Timer1/4 will also continue to run in the paused state. Peripherals that continue to run in a paused state may cause breaks, and you need to be aware when debugging.

29. Instruction Description

Assembly instructions consist of a total of 5 categories: arithmetic operations, logical operations, data transfer operations, Boolean operations, and program branch instructions, all of which are compatible with standard 8051.

29.1 Symbol Description

Symbol	Description
Rn	Working registers R0-R 7
Direct	The cell address (00H-FFH) of the internal data memory RAM or the address in the special function register SFR
@Ri	Indirection register (@R0 or @R1).
#data	8-bit binary constant
#dato16	A 16-bit binary constant in the instruction
Bit	Bit address in internal data memory RAM or special function register SFR
Addr16	16-bit address with an address range of 0-64KB address space
Addr11	11-bit address, address range 0-2KB address space
Rthe	Relative address
A	accumulator

29.2 List of Instructions

Mnemonics		description
Operation class		
ADD	A,R n	Accumulator plus register
ADD	A,direct	Accumulator plus direct addressing unit
ADD	A,@Rto	Accumulator plus indirectly addressed RAM
ADD	A,#data	The accumulator adds the immediate number
ADDC	A,Rn	Accumulator plus registers and carry flags
ADDC	A,direct	Accumulator plus direct addressing unit and carry signs
ADDC	A,@Rto	Accumulator plus indirect addressing RAM and carry flags
ADDC	A,#data	Accumulator plus immediate number and carry signs
SANDBB B	A,R n	Accumulator minus register and carry flag
SANDBB B	A,direct	Accumulator minus direct addressing unit and carry flag
SANDBB B	A,@Ri	Accumulator minus indirect addressing RAM and carry flags
SANDBB B	A,#data	Accumulator minus immediate number and carry signs
INC	A	Accumulator plus 1
INC	Rn	Register plus 1
INC	direct	Direct addressing unit plus 1
INC	@Ri	Indirect addressed RAM plus 1
INC	DPTR	Data pointer plus 1
DEC	A	Accumulator minus 1
DEC	Rn	Register minus 1
DEC	direct	Direct addressing unit minus 1
DEC	@ Ri	Indirect addressed RAM minus 1
MANDL	A,B	Accumulator multiplier by register B
DIV	A,B	The accumulator is divided by register B
DA	A	Decimal adjustment
Logical operation classes		
ANL	A,Rn	Accumulators and registers
ANL	A,direct	Accumulators and direct addressing units
ANL	A,@Rto	Accumulator and indirectly addressed RAM
ANL	A,#data	Accumulator with immediate number
ANL	direct,A	Direct addressing unit with accumulator
ANL	direct,#data	Direct addressing units with immediate numbers
ORL	A,R n	Accumulator or register
ORL	A, direct	Accumulator or direct addressing unit
ORL	A,@Rto	Accumulator or indirectly addressed RAM
ORL	A, #data	Accumulator or immediate number
ORL	direct,A	Direct addressing unit or accumulator
ORL	diri walkt,#dayour	Direct addressing units or immediate numbers
XRL	A,R n	Accumulator Xor register
XRL	A,direct	Accumulator heterogeneous or direct addressing unit
XRL	A,@Ri	Accumulator XOR addressed RAM
XRL	A,#data	Accumulator different or immediate number
XRL	direct,A	Direct addressing unit Xor accumulator
XRL	direct,#data	Direct addressing units vary or immediately number
CLR	A	Accumulator clear 0
CPL	A	The accumulator is reversed

Mnemonics		description
RL	A	The accumulator is shifted in the left loop
RLC	A	The accumulator is even the carry flag for a left loop shift
RR	A	The accumulator is shifted in the right loop
RR RC	A	The accumulator is connected to the carry mark right loop shift
SWAP	A	The accumulator is swapped 4 bits high and 4 bits low
Data transfer class		
MOV	A,R n	Registers are transferred to the accumulator
MOV	A,direct	The direct addressing unit is transferred to the accumulator
MOV	A,@Ri	Indirectly addressed RAM feed accumulator
MOV	A,#data	Immediately count the accumulators
MOV	Rn,A	Accumulator feed register
MOV	Rn,direct	Direct addressing unit feed register
MOV	Rn,#data	Immediately count the send registers
MOV	direc t,A	The accumulator sends a direct addressing unit
MOV	direc t,R n	Registers send direct addressing units
MOV	d irect1,direct2	The direct address unit is transferred to the direct addressing unit
MOV	d irect t,@Ri	Indirectly addressed RAM feeds direct addressing units
MOV	d irect,#data	Immediately count the number of direct addressed units
MOV	@Ri,A	The accumulator sends indirectly addressed RAM
MOV	@R i,direct	The direct addressing unit sends indirectly addressed RAM
MOV	@Ri,#datake	Immediately send indirect addressed RAM
MOV	DPTR,#data16	The 16-bit immediate number sends a data pointer
MOVC	A,@A+DPTR	Lookup table data feed accumulator (DPTR as base address)
MOVC	A,@A+PC	Lookup table data feed accumulator (PC as base address)
MOVX	A,@Rto	External RAM unit feed accumulator (8-bit address)
MOVX	A,@DPTR	External RAM unit feed accumulator (16-bit address)
MOVX	@Ri,A	Accumulator feeds external RAM unit (8-bit address)
MOVX	@DPTR,A	Accumulator to external RAM unit (16-bit address)
PUSH	direct	The direct addressing unit is pressed into the top of the stack
POP	direct	A direct addressing unit pops up at the top of the stack
XCH	A,Rn	The accumulator is exchanged with the registers
XCH	A, direct	The accumulator is swapped with the direct addressing unit RAM
XCH	A,@Ri	The accumulator is swapped with the indirect addressing unit RAM
XCHD	A,@Ri	The accumulator swaps 4 bits lower with the indirect addressing unit RAM
Boolean operation class		
CLR	C	C Clear Zero
CLR	bit	The direct address bit is cleared to zero
SETB	C	C set
SETB	bit	Direct addressing location bits
CPL	C	C takes the reverse
CPL	bit	Direct addressing bits are reversed
ANL	C,bit	C logic with direct addressing bits
ANL	C,/bit	C logic is inverse with direct addressing bits
ORL	C,bit	C logical or direct addressing bits
ORL	C,/bit	C logic or the inverse of the direct addressing bit
MOV	C,bit	Direct addressing bits send C
MOV	bit,C	C sends direct addressing bits
Program jump class		

Mnemonics		description
ACALL	add r11	Absolute invocation within the 2K address range
LCALL	addr16	Long calls within 64K address range
RAND		Subroutine returns
RETI		Interrupt returns
AJMP	addr11	Absolute transfer within 2K address range
LJMP	add r16	Long transfer within 64K address range
SJMP	randl	Relatively short transfer
JMP	@A+DPTR	Relatively long transfer
JZ	rthe	The accumulator is 0 transfers
JNZ	rthe	The accumulator is not transferred to 0
JC	rthe	C is 1 transfer
JNC	rthe	C is 0 transfer
JB	band t,r the	The direct addressing bit is 1 transfer
JNB	band t,r the	The direct addressing bit is transferred at 0
JBC	band t,r the	The direct addressing bit is transferred to 1 and clears that bit
CJNE	A,dandrec t,r the	Accumulators are transferred unequally from direct addressing units
CJNE	A,#data,r the	Accumulator with immediate number unequal transfer
CJNE	Rn,#data,r el	Registers are transferred with an immediate number unequal
CJNE	@ Ri,#data,r el	Indirection unit RAM with immediate number unequal transfer
DJNZ	Rn,r el	Register minus 1 does not transfer to 0
DJNZ	dandrec t,r the	Direct addressing unit minus 1 does not transfer to 0
NOB		Empty directive
Read-Modify-Write instructions		
ANL		Logical (direct ANL, A and DIRECT ANL, #data)
ORL		Logical or (ORL direct, A and ORL direct, #data)
XRL		Logical XOR (XRL direct, A vs XRL direct, #data)
JBC		The direct addressing bit is transferred to 1 and cleared (JBC bit, rel)
CPL		CPL bit
INC		Increment by 1 (INC direct)
DEC		Decrement by 1. (DEC direct)
DJNZ		Minus 1 does not transfer for 0 (DJNZ direct, rel)
MOV	bit,C	C sends direct addressing bits
CLR	bit	The direct address bit is cleared to zero
SETB	bit	Direct addressing location bits

30. Version Revision Notes

The version number	Time	Revision content
V1.00	Sep 2020	Initial release
V1.01	Dec 2022	Delete ADC clock frequency example, adjust I2C description, delete FLASH operation time related description, adjust port reuse function description, add BUZZER precautions, change some register bit descriptions, and optimize some text expressions
V1.0.2	Jan 2023	Modified the description of software clearing operations in 6.4.4
V1.0.3	May 2023	corrected the description of 19.2 Characteristic
V1.0.4	July 2023	<ol style="list-style-type: none">1) Added some remarks to section 25.2.72) Added the step "Clear the CRC end address select bit" to the function description in section 25.3